

# CHICKASHA

## COMMUNITY DEVELOPMENT

### NOTICE OF A MEETING FOR CITY OF CHICKASHA BOARD OF ADJUSTMENT

In compliance with Title 25, Oklahoma Statutes, Section 301-314, the Oklahoma Open Meeting Act, including the posting of notices and agenda, be advised that the **City of Chickasha Board of Adjustment** of the City of Chickasha, Oklahoma, meeting on **Thursday, March 12, 2026, at 4:00 PM.**

Said meeting will be held at City Hall, 2<sup>nd</sup> Floor City Council Chambers, 117 N. 4<sup>th</sup> Street, Chickasha, Oklahoma.

The City of Chickasha encourages participation from all its citizens. If special accommodations are needed, please notify the City Clerk at least 48 hours prior to the scheduled meeting. The City may waive the 48-hour rule if the necessary accommodations can be easily made.

**1 Call to Order / Roll Call.**

**2 Meeting Items**

- a. Discussion, Consideration and Possible action to approve the minutes from the December 12th, 2025 meeting.
- b. Public Hearing to discuss and consider the application by Michelle Marone requesting a variance from the Chickasha Code of Ordinances Sec 54-77 Accessory Building Location at 1002 S 5th St.
- c. Discussion, Consideration and Possible action to approve the application by Michelle Marone requesting a variance from the Chickasha Code of Ordinances Sec 54-77 Accessory Building Location at 1002 S 5th St.

**3 Motion to Adjourn.**

---

This Agenda was posted on the official City of Chickasha bulletin board in the Municipal Building, 117 North 4th Street Chickasha, OK, 73018, which is accessible to the public twenty-four hours each day at \_\_\_\_ a.m./p.m. on \_\_\_\_\_, 20\_\_\_\_.

# CHICKASHA

**Meeting Type: Board of Adjustment 3/12/26**

**Meeting Date: 3/12/2026**

**Department: Community Development**

**Agenda Item No. 2.a.**

**AGENDA ITEM: Discussion, Consideration and Possible action to approve the minutes from the December 12th, 2025 meeting.**

**I. BACKGROUND/DESCRIPTION:**

**II. RECOMMENDED ACTION:**

**III. FISCAL INFORMATION -**

**IV. FUND INFORMATION:**

<b>Dept. Director:</b> Jessica Green	Fund	Account	Amount
	(To)		
	FUND	ACCOUNT	AMOUNT
<b>Meeting Date:</b> March 12th, 2026	(From)		

**V. ATTACHMENTS:**

1. 12.16.25 minutes

# BOARD OF ADJUSTMENTS MEETING

December 12th, 2025

## 1. Call meeting to order: 4:04pm

Roll Call: Shevon Blair, Mike Mosley, Nita Ladd, Brandie Whitehead, Eric Anderson

Present: Blair, Mosley, Ladd, Whitehead, Anderson

Absent:

Blair arrived after the meeting started at 4:07pm

Staff Present: Danielle Charles, Jessica Green, Jim Crosby, Shae Mortimer, Ashlin Tryczak

Citizens: Shelby Boyd, Jayson Wilson, Kelly Boyd, Tanner Thompson

## 2. Meeting Items:

A. Discussion, Consideration and Possible action to approve the minutes from the October 29th, 2025, meeting.

\*Motion by Whitehead and second by Ladd to approve minutes from the October 29th, 2025, meeting.

Roll Call: Shevon Blaire, Mike Mosley, Nita Ladd, Brandi Whitehead, Eric Anderson

Ayes: Mike Mosley, Nita Ladd, Brandie Whitehead, Eric Anderson

Nays:

Abstain:

B. Public Hearing to discuss and consider the request for variance from the Chickasha

Code of Ordinances Sec 52-50 "Supplying Others" for Shelby Boyd at 805 S 29<sup>th</sup> St.

Hearing Opened: 4:06 PM

Hearing Closed: 4:24 PM

C. Discussion, consideration, and possible action to approve the variance from the Chickasha Code of Ordinances Sec 52-50 "Supplying Others" for Shelby Boyd at 805 S 29<sup>th</sup> St.

\*Motion by Blair and second by Whitehead to pass the variance from the Chickasha Code of Ordinances Sec 52-50 "Supplying Others" for Shelby Boyd at 805 S 29<sup>th</sup> St for further information about other properties on existing water line.

Roll Call: Shevon Blaire, Mike Mosley, Nita Ladd, Brandi Whitehead, Eric Anderson

Ayes: Blaire, Mosley, Ladd, Whitehead, Anderson

Nays:

Abstain:

### **3. Motion to Adjourn:**

\*Motion by: Whitehead and second by Ladd to adjourn the meeting.

Roll Call: Shevon Blaire, Mike Mosley, Nita Ladd, Brandi Whitehead, Eric Anderson

Ayes: Blaire, Mosley, Ladd, Whitehead, Anderson

Nays:

Abstain:

The meeting adjourned at: 4:25pm

# CHICKASHA

**Meeting Type: Board of Adjustment 3/12/26**

**Meeting Date: 3/12/2026**

**Department: Community Development**

**Agenda Item No. 2.b.**

**AGENDA ITEM: Public Hearing to discuss and consider the application by Michelle Marone requesting a variance from the Chickasha Code of Ordinances Sec 54-77 Accessory Building Location at 1002 S 5th St.**

**I. BACKGROUND/DESCRIPTION:**

The applicant wishes to be granted a variance from the Chickasha Code of Ordinance’s Sec 54-77 (3) Location. Applicants wishes to have accessory building located closer than 15 feet from the home and placed at the rear of the property due to limited yard space.

**II. RECOMMENDED ACTION:**

**III. FISCAL INFORMATION -**

**IV. FUND INFORMATION:**

<b>Dept. Director:</b> Jessica Green	Fund	Account	Amount
	(To)		
	FUND	ACCOUNT	AMOUNT
<b>Meeting Date:</b> March 12th, 2026	(From)		

**V. ATTACHMENTS:**

# CHICKASHA

**Meeting Type: Board of Adjustment 3/12/26**

**Meeting Date: 3/12/2026**

**Department: Community Development**

**Agenda Item No. 2.c.**

**AGENDA ITEM: Discussion, Consideration and Possible action to approve the application by Michelle Marone requesting a variance from the Chickasha Code of Ordinances Sec 54-77 Accessory Building Location at 1002 S 5th St.**

**I. BACKGROUND/DESCRIPTION:**

**II. RECOMMENDED ACTION:**

The applicant wishes to be granted a variance from the Chickasha Code of Ordinance’s Sec 54-77 (3) Location. Applicants wishes to have accessory building located closer than 15 feet from the home and placed at the rear of the property due to limited yard space.

**III. FISCAL INFORMATION -**

**IV. FUND INFORMATION:**

<b>Dept. Director:</b> Jessica Green	Fund	Account	Amount
	(To)		
	FUND	ACCOUNT	AMOUNT
<b>Meeting Date:</b> March 12th, 2026	(From)		

**V. ATTACHMENTS:**

1. Michelle Marone application\_Redacted
2. Michelle Marone abstractor
3. Michelle Marone Addresses
4. Michelle Marone mailer
5. Michelle Marone mortgage inspection report
6. Michelle Marone proof of publication



Sec 84-77 (3) Location



Due On: \_\_\_\_\_

Meeting Date: \_\_\_\_\_

APPLICATION FOR BOARD OF ADJUSTMENT

Request:  Variance  Special Exception  Appeal

Applicant(s) Name: Michelle A Marone 73018

Address: 1002 S 5th Street Chickasha Mailing Po Box

Legal Description: E 100 ft N 50 ft Lot 7 Block 215 2334 Chickasha

Address of subject property: 1002 S. 5th Street 73023

Phone #: [Redacted]

Present zoning classification of subject property: R2

Type of Variance/Special Exception being sought: Move shed to Driveway near

Reason for requesting variance/special exception: back of house south west driveway to have shelter in stall where shed currently is

Owner of Record: Michelle A. Marone as of 1/24/2020

The following is a checklist of all other requirements of the application:

- A letter requesting the variance/special exception and reasons why the variance/special exception is being sought.
- A plot plan showing the dimensions of the property and the location and dimensions of ALL structures located on the property in relation to the property lines. (The plan should be specific enough to represent the type of variance/special exception requested)
- An Abstractor's Certified Property Owners list of property owners within 300' of subject property.
- All Materials are due no later than the date set by the Community Development Director, as noted on this Application.

ALL INFORMATION ON THIS FORM MUST BE COMPLETED IN ORDER TO PROCESS YOUR REQUEST

Applicant(s) Signature: Michelle Marone Date: 2/5/2020

Please allow me to move  
my 16x20 shed from front  
of property 1002 S 5th St.  
Chickasha, OK 73018 to  
South west side of house  
onto drive way that is  
no longer shared with  
house on west side of  
drive way.

Thank you!

Michelle Amara  
PO Box 2336  
Chickasha OK 73023

# Untitled Map

Write a description for your map.

W Washington Ave

W Washington Ave

W Washington Ave

W Washington Ave

1002 S 5th St

S 5th St

S 5th St

**Legend**  
📍 1002 S 5th St

Google Earth

Image © 2026 Airbus

100 ft



**SPECIAL CERTIFICATE  
159309**

RE:

East 100 feet of the North 50 feet of Lot 1 in Block 215 to the City of Chickasha, Grady County, Oklahoma, according to the recorded plat thereof.

**THE FOLLOWING IS A LIST OF PROPERTY OWNERS WITHIN 300 FEET OF THE ABOVE DESCRIBED PROPERTY:**

**OWNER:**

423 W. Texas Ave Trust  
11408 E 110<sup>th</sup> St. N  
Owasso, OK 73005

**DESCRIPTION:**

Lot 8 Block 193 Chickasha OT, Chickasha Oklahoma

**OWNER:**

Munoz, Joanna R.  
211 Oliver Dr.  
Anadarko, OK 73005

**DESCRIPTION**

Lot 1 Block 194 Chickasha OT, Chickasha Oklahoma

**OWNER:**

Eyes On Properties, LLC  
PO BOX 14954  
Oklahoma City, OK 73113

**DESCRIPTION**

E 50' Lot 8 Block 194, Chickasha OT, Chickasha Oklahoma

**OWNER:**

Eyes On Properties, LLC  
PO BOX 14954  
Oklahoma City, OK 73113

**DESCRIPTION:**

W 52.5' E 105' Lots 7 and 8 Block 215 Chickasha OT, Chickasha Oklahoma

**OWNER:**

Eyes On Properties, LLC  
PO BOX 14954  
Oklahoma City, OK 73113

**DESCRIPTION:**

N 50' Lot 6 and S 25' Lot 7 Block 194 Chickasha OT, Chickasha Oklahoma

**OWNER:**

Eyes On Properties, LLC  
PO BOX 14954  
Oklahoma City, OK 73113

**DESCRIPTION:**

N 25' Lot 5 & S 25' Lot 6 Block 194 Chickasha OT, Chickasha Oklahoma

**OWNER:**

Eyes On Properties, LLC  
PO BOX 14954  
Oklahoma City, OK 73113

**DESCRIPTION:**

S 50' Lot 5 Block 194, Chickasha OT, Chickasha Oklahoma

**OWNER:**

Jan's Properties, LLC  
2591 County Street 2780  
Chickasha, OK 73018

**DESCRIPTION:**

E 52.5' Lot 7 and E 52.5' Lot 8 Block 215, Chickasha OT, Chickasha Oklahoma

**OWNER:**

Dolch, Ethan & Emily Resendez  
525 Tumbleweed Dr.  
Forney, TX 75126

**DESCRIPTION:**

Lot 7 LESS the S 25' Block 194 Chickasha OT, Chickasha Oklahoma

**OWNER:**

James, Blaise & June  
1004 S 4<sup>th</sup> St  
Chickasha, OK 73018

**DESCRIPTION:**

Lot 1 & N 25' Lot 2 Block 216 Chickasha OT, Chickasha Oklahoma

**OWNER:**

James, Blaise & June  
1002 S 4<sup>th</sup> St  
Chickasha, OK 73018

**DESCRIPTION:**

N 50' Lot 3 Block 216 Chickasha OT, Chickasha Oklahoma

**OWNER:**

Sanders, Sherry  
928 S. 5<sup>th</sup> St  
Chickasha, OK 73018

**DESCRIPTION:**

S 10' Lot 3 and All Lot 4 Block 194 Chickasha OT, Chickasha Oklahoma

**OWNER:**

Crosby, John & Elizabeth  
4300 NW 10<sup>th</sup> St  
Coconut Creek, FL 33066

**DESCRIPTION:**

Lot 5 & S 25' Lot 6 Block 216 Chickasha OT, Chickasha Oklahoma

**OWNER:**

Pool, Pat & Janell Ludwell  
1028 S 5<sup>th</sup> St  
Chickasha, OK 73018

**DESCRIPTION:**

Lots 3 & 4 Block 215 Chickasha OT, Chickasha Oklahoma

**OWNER:**

Howell Rentals, LLC  
112 Rosewood Dr  
Chickasha, OK 73018

**DESCRIPTION:**

E 100' N 50' Lot 1 Block 215 Chickasha OT, Chickasha Oklahoma

**OWNER:**

Howell Rentals, LLC  
112 Rosewood Dr  
Chickasha, OK 73018

**DESCRIPTION:**

S 25' Lot 1 & N 25' Lot 2 Block 215 Chickasha OT, Chickasha Oklahoma

**OWNER:**

Hoffman Holdings LLC  
628 S 6<sup>th</sup> St  
Chickasha, OK 73018

**DESCRIPTION:**

Lot 5 Block 215 Chickasha OT, Chickasha Oklahoma

**OWNER:**

Shaw, Amanda  
515 Washington  
Chickasha, OK 73018

**DESCRIPTION:**

W 65' of N 50' Lot 1 Block 215 Chickasha OT, Chickasha Oklahoma

**OWNER:**

Pearce, Donald & Kledy Cortez  
2452 County Road 1406  
Alex, OK 73002

**DESCRIPTION:**

N 65' Lot 3 Block 194 Chickasha OT, Chickasha Oklahoma

**OWNER:**

Shoemake, Preston W.  
1383 County Road 1400  
Chickasha, OK 73018

**DESCRIPTION:**

N 26' Lot 7 & S 23' Lot 8 Block 216 Chickasha OT, Chickasha Oklahoma

**OWNER:**

Kizzia, Bobby M  
2392 County Street 2876  
Chickasha, OK 73018

**DESCRIPTION:**

S 49' Lot 7 Block 216 Chickasha OT, Chickasha Oklahoma

**OWNER:**

Daniels, Dawn R.  
906 S 5<sup>th</sup> St  
Chickasha, OK 73018

**DESCRIPTION:**

Lot 2 Block 194 Chickasha OT, Chickasha Oklahoma

**OWNER:**

McCarther Investment Properties, LLC  
1308 Arizona Ave.  
Chickasha, OK 73018

**DESCRIPTION:**

S 50' Lot 2 Block 215 Chickasha OT, Chickasha Oklahoma

**OWNER:**

New American Funding FKA Broker Solutions Inc  
8201 North FM 620 STE 120  
Austin, TX 78726

**DESCRIPTION:**

N 50' Lot 6 Block 216 Chickasha OT, Chickasha Oklahoma

**OWNER:**

Sandoval Living Trust  
2236 County Street 2780  
Verden, OK 73092

**DESCRIPTION:**

W 74.10' Lot 4 & W 74.10' S 10' Lot 3 Block 193 Chickasha OT, Chickasha Oklahoma

**OWNER:**

Ferguson, Dylan Keith & Cynthia G. Ferguson  
420 Washington  
Chickasha, OK 73018

**DESCRIPTION:**

E 57' Lots 5 & 6 and S 15' of E 57' Lot 7 Block 193 Chickasha OT, Chickasha Oklahoma

**OWNER:**

Lister, Paula S & Cheryl M. Lister  
4616 Emerald Knoll Rd.  
Oklahoma City, OK 73179

**DESCRIPTION:**

N 60' Lot 7 Block 193 Chickasha OT, Chickasha Oklahoma

**OWNER:**

McNatt Commercial Investments LLC  
3390 County Street 2850  
Ninnekah, OK 73067

**DESCRIPTION:**

N 52' Lot 8 Block 216 Chickasha OT, Chickasha Oklahoma

**OWNER:**

Rangel, Angel  
1515 W Iowa Ave  
Chickasha, OK 73018

**DESCRIPTION:**

S 50' Lot 2 Block 216 Chickasha OT, Chickasha Oklahoma

**OWNER:**

ZP Properties, LTD Co.  
724 NW 18<sup>th</sup> St  
Oklahoma City, OK 73103

**DESCRIPTION:**

W 60' Lots 7-8 Block 215 Chickasha OT, Chickasha Oklahoma

**OWNER:**

Mann, Patsy Und 1/4 Int & Erica Mann Und 1/4 Int & Roxanne Williams Und 1/4 Int  
3010 W Montana Ave  
Chickasha, OK 73018

**DESCRIPTION:**

Lot 6 Block 215 Chickasha OT, Chickasha Oklahoma

**OWNER:**

Williams, Gary L. & Darla J.  
1423 S 9<sup>th</sup> St  
Chickasha, OK 73018

**DESCRIPTION:**

W 108' Lots 5 & 6 & S 15' of W 108' Lot 7 Block 193 Chickasha OT, Chickasha Oklahoma

Said properties are within the limits of the City of Chickasha, Grady County, Oklahoma. The following are the known utility companies and franchise holders:

- |                           |                |
|---------------------------|----------------|
| 1. City of Chickasha      | 4. Sudden Link |
| 2. Centerpoint Energy     | 5. A T & T     |
| 3. Public Service Company |                |

STATE OF OKLAHOMA

SS

COUNTY OF GRADY

The undersigned lawfully Bonded Abstracters in and for said County and State, do hereby certify that the foregoing attached sheets contain a true and complete take-off of the names and addresses of the taxpayers of the real property opposite their names, according to the records in the office of the County Treasurer and County Assessor of Grady County, Oklahoma, for the calendar year of 2025.

The Abstracter does not pass on the validity or sufficiency of any instrument of record, nor the marketability of the title; nor do we assume any liability in the excess of \$300.00 in furnishing this report. Dated at Chickasha, Grady County, Oklahoma, this 3rd day of February, 2026 @ 7:59 A.M.

WASHITA VALLEY ABSTRACT & TITLE, LLC

By

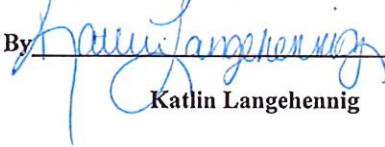

Katlin Langehennig

426 W Texas Trust  
11408 W 110<sup>th</sup> St N  
Owasso, OK 73005

Joanna R Munoz  
211 Oliver Dr  
Anadarko, OK 73005

Eyes on Properties, LLC  
PO BOX 14954  
Oklahoma City, OK 73113

Eyes on Properties, LLC  
PO BOX 14954  
Oklahoma City, OK 73113

Eyes on Properties, LLC  
PO BOX 14954  
Oklahoma City, OK 73113

Eyes on Properties, LLC  
PO BOX 14954  
Oklahoma City, OK 73113

Eyes on Properties, LLC  
PO BOX 14954  
Oklahoma City, OK 73113

Jan's Properties, LLC  
2591 County Street 2780  
Chickasha, OK 73018

Dolch, Ethan & Emily Resendez  
525 tumbleweed Dr  
Forney, TX 75126

Blaise & June James  
102 S 4<sup>th</sup> St  
Chickasha, OK 73018

Sherry Sanders  
928 S 5<sup>th</sup> St  
Chickasha, OK 73018

John & Elizabeth Crosby  
4300 NW 10<sup>th</sup> St  
Coconut Creek, FL 33066

Pat & Janell Ludwell Pool  
1028 S 5<sup>th</sup> St  
Chickasha, OK 73018

Howell Rentals, LLC  
112 Rose Dr  
Chickasha, OK 73018

Howell Rentals, LLC  
112 Rose Dr  
Chickasha, OK 73018

Hoffman Holdings, LLC  
628 S 6<sup>th</sup> St  
Chickasha, OK 73018

Amanda Shaw  
515 Washington  
Chickasha, OK 73018

Donald & Kledy Cortez Pearce  
2452 County Road 1406  
Alex, OK 73002

Preston W Shoemake  
1838 County Road 1400  
Chickasha, OK 73018

Bobby M Kizzia  
2392 County Street 2876  
Chickasha, OK 73018

Dawn R Daniels  
906 S 5<sup>th</sup> St  
Chickasha, OK 73018

McCarther Investment Properties  
LLC  
1308 Arizona Ave  
Chickasha, OK 73018

New American Funding FKA Broker  
Solutions Inc  
8201 North FM 620 STE 120  
Austin, TX 78726

Sandoval Living Trust  
2236 County Street 2780  
Verden, OK 73092

Dylan Keith & Cynthai G Ferguson  
420 Washington  
Chickasha, OK 73018

Paula & Cheryl M Lister  
4616 Emerald Knoll Rd  
Oklahoma City, OK 73179

McNatt Commercial Investments  
LLC  
3390 County Street 2850  
Ninnekah, OK 73067

Angel Rangel  
1515 W Iowa Ave  
Chickasha, OK 73018

ZP Properties, LTD Co.  
724 NW 18<sup>th</sup> St  
Oklahoma City, OK 73103

Patsy Mann, Erica Mann, &  
Roxanne Williams  
3010 W Montana Ave  
Chickasha, OK 73018

Gary & Darla Williams  
1423 S 9<sup>th</sup> St  
Chickasha, OK 73018

# CHICKASHA

## COMMUNITY DEVELOPMENT

### NOTICE OF PUBLIC HEARING

#### BOA PETITION

#### REQUEST FOR A VARIANCE OF THE CHICKASHA CODE OF ORDINANCES

NOTICE IS HEREBY GIVEN, that the City of Chickasha Board of Adjustment will hold a public hearing beginning at 4:00 p.m. on Thursday March 12<sup>th</sup>, 2026, at Chickasha City Hall, 117 North 4<sup>th</sup> St., Chickasha, Oklahoma. This public hearing concerns the petition by Michelle Marone requesting a variance from the Chickasha Code of Ordinances. The limit of the proposed variance includes the following described property:

***Located at 1002 S 5<sup>th</sup> - 33-07-07-42150 E 100' OF N 50' LOT 1 BLK 215 CHICKASHA-OT***

**BRIEF DESCRIPTION OF REQUEST:** The applicant wishes to be granted a variance from the Chickasha Code of Ordinance's Sec 54-77 (3) Location. Applicants wishes to have accessory building located closer than 15 feet from the home and placed at the rear of the property due to limited yard space.

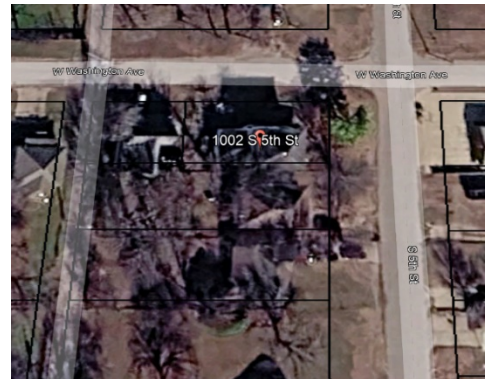

Any person supporting or having any objections to this petition may appear before the Board of Adjustment on the above date set for hearing and show cause why the petition should or should not be approved. Written comments regarding this petition should be emailed to [jessica.green@chickasha.org](mailto:jessica.green@chickasha.org) or be mailed to City of Chickasha, Community Development Department, 117 North 4<sup>th</sup> Street Chickasha, Oklahoma 73018.

Please call the Community Development Department at 405-222-6010 or email [Jessica.green@chickahsa.org](mailto:Jessica.green@chickahsa.org) should you have any questions regarding this petition.

Sincerely,

Jessica Green,

Community Development Director

MORTGAGE INSPECTION REPORT  
 PORTIONS OF SECTION 33, TOWNSHIP 7 NORTH, RANGE 7 WEST

GRADY COUNTY, OKLAHOMA

1002 S 5TH STREET,  
 CHICKASHA, OK 73018

MICHELLE A. MARONE

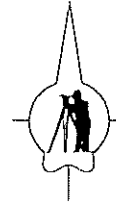
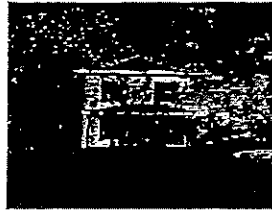
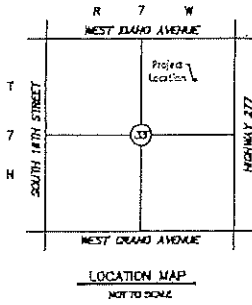

**PATRIOT**  
 SURVEY  
*Heritage Matters*

WEST WASHINGTON AVENUE (Legal Access)

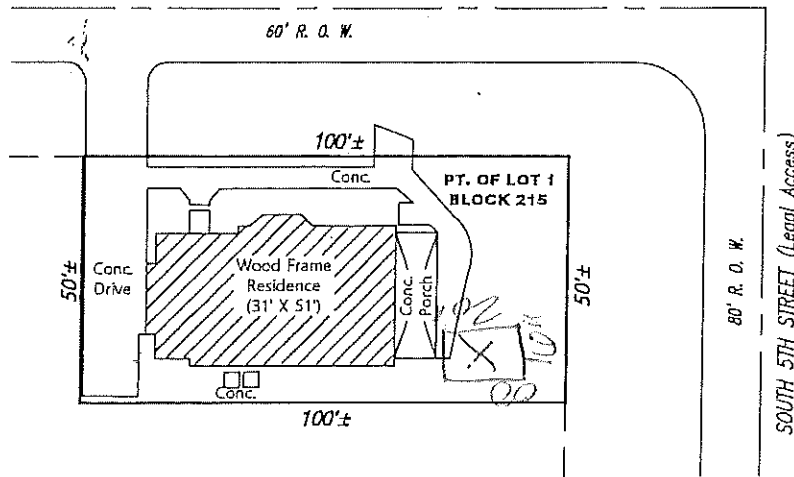

**TRACT DESCRIPTION**

The East 100 feet of the North 50 feet of Lot 1 in Block 215 to the City of Chickasha, Grady County, Oklahoma, according to the recorded plat thereof.

**TITLE INFORMATION**

Washita Valley Abstract & Title, LLC, File No.: 26-01-8707, effective January 2, 2026. Easements noted on Schedule B, Sec. II: Plat - easements shown. No additional easements noted.

**SURVEYOR CERTIFICATION**

I certify that the above inspection report shows the improvements, other than fences, as located on the premises described, that they are entirely within the described tract boundaries are based upon physical features, there are no significant encroachments, except as indicated, that the above report shows all recorded plat and other such easements as have been disclosed and furnished to me by the client, that the report was prepared for identification purposes only for the mortgages and IS NOT A LAND OR PROPERTY LINE SURVEY, that NO CORNERS WERE SET and IT IS NOT TO BE RELIED UPON FOR THE ESTABLISHMENT OF FENCE, BUILDING OR OTHER IMPROVEMENT LINES. No liability is assumed herein for future landowners or lending institutions. This Certification IS NOT TRANSFERABLE. If the Surveyors Seal and signature are not in color, this is an unauthorized copy. FEDERAL COPYRIGHT LAWS APPLY.

*David L. M. Louy* 01/13/2026  
 DAVID L. M. LOUY, OKLS #1310 DATE

R.O.W. = Right of Way

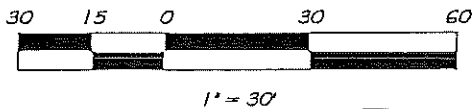

CALL OKIE  
 800-522-OKIE (6543)

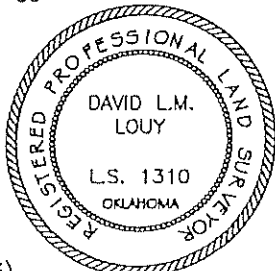

Job: # 50363 - Buyer - MARONE



**PATRIOT**  
 SURVEY  
 P. O. Box 966, Jenks OK 74037  
 1-833-752-8833  
 CA 8229, Eff. to 6-30-2027

# PROOF OF PUBLICATION

In the District Court of Grady County, State of Oklahoma

1002 S. 5TH

Affidavit of Publication

State of Oklahoma, County of Grady, ss:

I, the undersigned publisher, editor or Authorized Agent of the Chickasha Daily Express, do solemnly swear that the attached advertisement was published in said paper as follows:

02/19/2026

That said newspaper is Weekly, in the city of Chickasha, Grady County, Oklahoma, a Weekly newspaper qualified to publish legal notices, advertisements and publications as provided in Section 106 of Title 25, Oklahoma Statutes 1971, as amended, and complies with all other requirements of the laws of Oklahoma with reference to legal publications.

That said Notice, a true copy of which is attached hereto, was published in the regular edition of said newspaper during the period and time of publications and not in a supplement, on the above noted dates.

  
Signature

Subscribed and sworn before me on this 27th day of February, 2026

  
Katherine Miller, Notary Public  
My commission expires 07/26/2028  
Commission # 24009395

Cost of Publication \$ 58.68

Ad # 167881

Acct # 44095

Copies: 1

PAY TO:

The Express Star  
PO Drawer E  
Chickasha, OK 73023



Published In  
The Express-Star  
February 19, 2026  
1 time  
LPXLP

NOTICE OF PUBLIC HEARING  
BOA PETITION  
REQUEST FOR A VARIANCE OF  
THE CHICKASHA CODE OF OR-  
DINANCES

NOTICE IS HEREBY GIVEN, that the City of Chickasha Board of Adjustment will hold a public hearing beginning at 4:00 p.m. on Thursday March 12th, 2026, at Chickasha City Hall, 117 North 4th St., Chickasha, Oklahoma. This public hearing concerns the petition by Michelle Marone requesting a variance from the Chickasha Code of Ordinances. The limit of the proposed variance includes the following described property:

Located at 1002 S 5th - 33-07-07-42150 E 100' OF N 50' LOT 1 BLK 215 CHICKASHA-OT

BRIEF DESCRIPTION OF REQUEST: The applicant wishes to be granted a variance from the Chickasha Code of Ordinance's Sec 54-77 (3) Location. Applicants wishes to have accessory building located closer than 15 feet from the home and placed at the rear of the property due to limited yard space.

Any person supporting or having any objections to this petition may appear before the Board of Adjustment on the above date set for hearing and show cause why the petition should or should not be approved. Written comments regarding this petition should be emailed to [jessica.green@chickasha.org](mailto:jessica.green@chickasha.org) or be mailed to City of Chickasha, Community Development Department, 117 North 4th Street Chickasha, Oklahoma 73018.

Please call the Community Development Department at 405-222-6010 or email [jessica.green@chickasha.org](mailto:jessica.green@chickasha.org) should you have any questions regarding this petition.

Sincerely,  
Jessica Green,  
Community Development Director