

NOTICE OF REGULAR MEETING
OF THE
CHICKASHA CITY COUNCIL

In compliance with Title 25, Oklahoma Statutes, Section 301-314, the Oklahoma Open Meeting Act, including the posting of notice and agenda, be advised that the Chickasha City Council, Chickasha Municipal Authority, and Chickasha Municipal Airport Authority of the City of Chickasha, Oklahoma, will conduct a **REGULAR MEETING ON MONDAY, APRIL 6, 2026, AT 6:30 PM.** Said meeting will be held in the Council Chambers, City Hall, 117 North 4th Street, Chickasha, Oklahoma.

The City of Chickasha encourages participation from all its citizens. If participation is not possible due to a disability, notification to the City Clerk at least 48 hours prior to the scheduled meeting is encouraged to make the necessary accommodations. The City may waive the 48-hour rule if signing is not the necessary accommodation.

All items on this agenda, including but not limited to any agenda item concerning the adoption of any ordinance, resolution, contract, agreement, or any other item of business, are subject to amendment, including additions and/or deletions. This rule will apply to every individual agenda item without exception, and without providing this same amendment language with respect to each individual agenda item. Such amendments should be rationally related to the topic of the agenda item, or the governing body will be advised to continue the item.

The governing body may adopt, approve, ratify, deny, defer, recommend, amend, strike, or continue any agenda item. When more information is needed to act on an item, the governing body may refer the matter to its City/Trust Manager, staff, attorney or to the recommending board, commission or committee.

Agenda items are attached.

I, Susan M. McDaniel, City Clerk, posted this Agenda on the official City of Chickasha bulletin board in the Municipal Building, 117 North 4th Street, Chickasha, OK, 73018, which is accessible to the public twenty-four hours each day at 4:30 p.m. on Wednesday, April 1, 2026.

Susan M. McDaniel

Susan McDaniel, CMC - City Clerk

Sworn to and subscribed before me on this 1st day of April 2026.

My Commission Expires: 10-1-2026



Tracey Lynn Austin

Notary Public, State of Oklahoma

CHICKASHA CITY COUNCIL

AGENDA

LOCATION OF MEETING

CITY HALL COUNCIL CHAMBERS

117 NORTH FOURTH STREET

CHICKASHA, OKLAHOMA 73018

TIME OF MEETING

6:30 PM

DATE OF MEETING

APRIL 6, 2026

All items on this agenda, including but not limited to any agenda item concerning the adoption of any ordinance, resolution, contract, agreement, or any other item of business, are subject to amendment, including additions and/or deletions. This rule will apply to every individual agenda item without exception, and without providing this same amendment language with respect to each individual agenda item. Such amendments should be rationally related to the topic of the agenda item, or the governing body will be advised to continue the item.

The governing body may adopt, approve, ratify, deny, defer, recommend, amend, strike, or continue any agenda item. When more information is needed to act on an item, the governing body may refer the matter to its City/Trust Manager, staff, attorney or to the recommending board, commission or committee.

- 1. Call to Order / Roll Call / Opening Prayer / Pledge of Allegiance.**

- 2. Citizen Comments.**

- 3. Council Communications.**
 - a. Proclamation Signing — Purple Heart City
 - b. Judge Chaffin will administer the Police Officer Oath of Office to Cheyenne Mann.
 - c. Fire Department Badge pinning ceremony — Aaron Holcomb.
 - d. Junior Council Presentation

- 4. Consent Docket:**

- a. Approve the Minutes of the February 23, 2026, Special meeting; Minutes of the March 2, 2026, Regular meeting; and the Minutes of the March 23, 2026, Special meeting.
- b. Acceptance of the Claims List.
- c. Acknowledge receipt of the Financials for February 2026.
- d. Approval of Quote from Tyler Technologies for 3 additional credit card readers
- e. Acceptance of a Memorandum of Understanding for Animal Welfare Conference Scholarship
- f. Approve purchase of a 10x20 Lofted Barn for the Animal Welfare Division
- g. Approve Tyler Technologies Interface Agreement for DigiTicket imports
- h. Approve the request from the Senior Class Sponsor to conduct the 2026 Senior Car Parade on Monday, May 18, 2026, @ 4:30 p.m.
- i. Approve the Fireworks Display for Grand Assembly dba Vital Church located at 102 E. Almar Drive on Friday, July 3, 2026.
- j. Acknowledge receipt of the Economic Development Council of Chickasha, Inc. Check Details for February 2026.
- k. Approve the 18th Annual Chickasha Area Arts Council Rock Island Arts Festival and the Annual Food Truck Championship during Friday, October 2nd and Saturday, October 3, 2026, and authorize street closures as requested.
- l. Approve the Chickasha Area Arts Council Mini Festival set for June 6, 2026, and waive any associated fees.
- m. Approve Open Streets event scheduled for May 2, 2026, and waive any associated fees.

5. Discussion/Approval of Items Removed from Consent Docket:

6. Discussion and Consideration

- a. Discussion, consideration, and possible action to accept the Financial Audit for the Fiscal Year Ending June 30, 2024.
- b. Public Hearing to discuss and consider the Rezoning for 512 S 18th from R-1 to R-3 for applicant Nicole Myers.
- c. Discussion, consideration, and possible action to approve Ordinance

2026-07 rezoning request for 512 S 18th for applicant Nicole Myers from R-1 to R-3.

- d. Public Hearing to discuss and consider the Rezoning for 624 N 10th from R-1 to R-2 for applicant Brandon Smith.
- e. Discussion, consideration and possible action to approve Ordinance 2026-08 rezoning request for 624 N 10th for applicant Brandon Smith from R-1 to R-2.
- f. Public Hearing to discuss and consider the Rezoning for 620 N 10th from R-1 to R-2 for applicant Brandon Smith.
- g. Discussion, consideration and possible action to approve Ordinance 2026-09 - Rezoning request for 620 N 10th for applicant Brandon Smith from R-1 to R-2.
- h. Discussion, consideration and possible action to approve a release of credit for Enclave Estates Phase 1.
- i. Discussion, consideration and possible action to approve a Bond for Enclave Estates for Phase 2
- j. Discussion, consideration and possible action to approve Final Plat for Enclave Estates Phase 2.,
- k. Discussion, consideration and possible action to approve a service agreement with Smith Roberts Baldischwiler, LLC (SRB) for GIS database.
- l. Discussion, consideration and possible action to approve an Amendment to the Agreement with Tyler Technologies, Inc. updating payment processing pricing, and authorizing execution of the same.
- m. Discussion, consideration and possible action to approve an agreement with Dobson Fiber to provide 2GB of internet service with static IP at Shannon Springs Park in a monthly amount not to exceed \$255 and authorize the Mayor to execute the same.
- n. Discussion, consideration and possible action to approve an agreement with Standley Systems to add two printers to our contract and authorize the mayor to execute the same.
- o. Discussion, consideration, and possible action to accept a quote in the amount of \$47,796.25 from Keystone Services Inc. for maintenance work on the parking lot at the Chickasha Sports Complex.
- p. Discussion, consideration, and possible action to appoint Mary K. Parrish to the Library Advisory Board with a term to expire June 30, 2028.
- q. Discussion, consideration, and possible action on Resolution 2026-12R
— A RESOLUTION OF THE CITY COUNCIL OF THE CITY OF CHICKASHA, GRADY COUNTY, STATE OF OKLAHOMA, AUTHORIZING THE INSTALLATION OF CERTAIN STREETLIGHTS BY AMERICAN ELECTRIC POWER AT SPECIFIED LOCATIONS WITHIN THE CITY; PROVIDING FOR

PAYMENT OF THE APPLICABLE MONTHLY CHARGES; AND PROVIDING FOR AN EFFECTIVE DATE.

- r. Discussion, consideration and possible action to declare certain Animal Welfare Division equipment as surplus, including Maytag washers and dryer, a Fishtrend camera system, and an HP computer; waive competitive bidding pursuant to Section 2-219(d) of the City Code; and authorize disposal and transfer to other governmental entities, finding such transfer serves a valid public purpose.
- s. Discussion, consideration and possible action to approve an Interlocal Cooperation Agreement for participation in The Oklahoma Purchasing System (TOPS) and authorize the Mayor to execute the agreement.
- t. Discussion, consideration and possible action to approve an oil and gas lease with Continental Resources, Inc. following a public auction pursuant to Title 64 Sections 1081 and 1082 for the following described property: An undivided 220.00 acres, more or less, in the N/2 NE/4, S/2 NE/4, SE/4 Section 10, Township 8 North, Range 9 West, Caddo County, Oklahoma
- u. Discussion, consideration, and possible action to approve temporary street closure of the 100 block of Chickasha Avenue for the monthly held Coffee & Cars Downtown on the last Saturday of each month of 2026 and waive any associated fees.
- v. Discussion, consideration, and possible action to approve the request from the Chickasha Youth Baseball to use the Sports Complex for the Spring 2026 Season and waive any associated fees.

7. Motion to Adjourn.

CHICKASHA

Meeting Type: Council Agenda 4-6-2026

Meeting Date: 4/6/2026

Department: City Clerk

Agenda Item No. 3.a.

AGENDA ITEM: Proclamation Signing — Purple Heart City

I. BACKGROUND/DESCRIPTION:

II. RECOMMENDED ACTION:

III. FISCAL INFORMATION -

IV. FUND INFORMATION:

Dept. Director:	Fund	Account	Amount
	(To)		
	FUND	ACCOUNT	AMOUNT
Meeting Date: April 6, 2026	(From)		

V. ATTACHMENTS:

1. 20260401135637048

PROCLAMATION

OFFICE OF THE MAYOR
CITY OF CHICKASHA
CHICKASHA, OKLAHOMA

OFFICIAL PROCLAMATION

WHEREAS, the citizens of Chickasha have great admiration and gratitude for the men and women who have selflessly served their country and this community in the Armed Forces; and

WHEREAS, the Purple Heart is the oldest military decoration in present use and was initially created as the Badge of Military Merit by George Washington in 1782; and

WHEREAS, the Purple Heart was the first American service award or decoration made available to the common soldier and is specifically awarded to members of the United States Armed Forces who have been wounded or paid the ultimate sacrifice in combat; and

WHEREAS, the City of Chickasha appreciates the sacrifices our Purple Heart recipients made in defending our freedoms and acknowledges those men and women for their courage by showing our support and honor; and

NOW, THEREFORE, be it resolved that I, Zachary Grayson, by the powers vested in me as Mayor of the City of Chickasha, Oklahoma and all its Citizens, do hereby proclaim Chickasha to be a

“PURPLE HEART CITY”.

IN WITNESS WHEREOF, I have hereunto set my hand and caused the official seal of the City of Chickasha to be affixed this 6th day of April 2026.

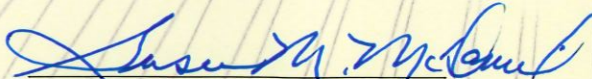
Susan M. McDaniel, CMC – City Clerk

Zachary Grayson, Mayor



CHICKASHA

Meeting Type: Council Agenda 4-6-2026

Meeting Date: 4/6/2026

Department: Police Department

Agenda Item No. 3.b.

AGENDA ITEM: Judge Chaffin will administer the Police Officer Oath of Office to Cheyenne Mann.

I. BACKGROUND/DESCRIPTION:

Judge Chaffin will administer the Police Officer Oath of Office to Cheyenne Mann.

II. RECOMMENDED ACTION:

III. FISCAL INFORMATION -

IV. FUND INFORMATION:

Dept. Director: Goebel Music, #300 Chief of Police	Fund	Account	Amount
	(To)		
	FUND	ACCOUNT	AMOUNT
Meeting Date: 04.06.2026	(From)		

V. ATTACHMENTS:

CHICKASHA

Meeting Type: Council Agenda 4-6-2026

Meeting Date: 4/6/2026

Department: Fire Department

Agenda Item No. 3.c.

AGENDA ITEM: Fire Department Badge pinning ceremony — Aaron Holcomb.

I. BACKGROUND/DESCRIPTION:

II. RECOMMENDED ACTION:

III. FISCAL INFORMATION -

IV. FUND INFORMATION:

Dept. Director: Tony Samaniego, Fire Chief	Fund	Account	Amount
	(To)		
	FUND	ACCOUNT	AMOUNT
Meeting Date: April 6, 2026	(From)		

V. ATTACHMENTS:

CHICKASHA

Meeting Type: Council Agenda 4-6-2026

Meeting Date: 4/6/2026

Department: Administration

Agenda Item No. 3.d.

AGENDA ITEM: Junior Council Presentation

I. BACKGROUND/DESCRIPTION:

Chickasha Junior Council Members will share a presentation from their year of service.

II. RECOMMENDED ACTION:

III. FISCAL INFORMATION -

IV. FUND INFORMATION:

Dept. Director: Shae Mortimer, Marketing Director	Fund	Account	Amount
	(To)		
	FUND	ACCOUNT	AMOUNT
Meeting Date: April 6, 2026	(From)		

V. ATTACHMENTS:

CHICKASHA

Meeting Type: Council Agenda 4-6-2026

Meeting Date: 4/6/2026

Department: City Clerk

Agenda Item No. 4.a.

AGENDA ITEM: Approve the Minutes of the February 23, 2026, Special meeting; Minutes of the March 2, 2026, Regular meeting; and the Minutes of the March 23, 2026, Special meeting.

I. BACKGROUND/DESCRIPTION:

II. RECOMMENDED ACTION:

Approve the Minutes of the February 23, 2026, Special meeting; Minutes of the March 2, 2026, Regular meeting; and the Minutes of the March 23, 2026, Special meeting.

III. FISCAL INFORMATION -

IV. FUND INFORMATION:

Dept. Director: Susan M. McDaniel, CMC City Clerk	Fund	Account	Amount
	(To)		
	FUND	ACCOUNT	AMOUNT
Meeting Date: April 6, 2026	(From)		

V. ATTACHMENTS:

1. City 2-23-2026
2. City 3-2-2026
3. City 3-23-2026

February 23, 2026

The **SPECIAL** meeting of the **CHICKASHA CITY COUNCIL** was held in the council chambers in city hall on the 23rd day of February 2026 as specified by advance public notice with a properly prepared agenda stating the subject matter or matters to be discussed at said meeting. Mayor Grayson called the meeting to order at 6:00 p.m.

ITEM 1. **Call to Order / Roll Call / Opening Prayer / Pledge of Allegiance**

MAYOR AND COUNCIL

PRESENT: Zachary Grayson, Mayor
 Georgianne Hebblethwaite, Vice-Mayor
 Lisa Hatchett
 Kim Irving
 Kea Ginn
 Erica Alexander
 Clark Southard

ABSENT: John Smith
 Charlie Burruss

STAFF

PRESENT: Jim Crosby, City Manager
 Susan McDaniel, City Clerk
 Jessica Green, Community Development Director
 Edward Perez, EM Director
 Shae Mortimer, Marketing and Civic Engagement Manager

ITEM 1. **Call to Order/Roll Call:**

Roll call:

Hatchett – Present
Irving – Present
Ginn - Present
Hebblethwaite – Present
Alexander - Present
Southard - Present
Grayson - Present

ITEM 2. **Consent Docket:**

ITEM 2a. **Acceptance of the Oklahoma Environmental Quality Permit No. WT000026250652 – Water Treatment Plant Improvement Project, with 6 MGC Design Capacity System Improvements.**

Motion by Council Member Alexander, second by Council Member Hatchett to approve Consent Docket as presented.

Roll call vote:

“Ayes:” Hatchett, Irving, Ginn, Hebblethwaite, Alexander, Southard, and Grayson.
“Nays:” None
“Abstain:” None
Motion carried. 7-0

ITEM 3. **Discussion and Consideration Items:**

ITEM 3a. **Discussion, consideration, and possible action to approve Resolution No. 2026-08R; a Resolution of the City of Chickasha, Oklahoma (the “City”) approving action taken by the Chickasha Municipal Authority (the “Authority”) authorizing issuance, sale and delivery of a promissory note of the Authority to the Oklahoma Water Resources Board; ratifying and confirming a Lease Agreement; ratifying and confirming a Sales Tax Agreement; and containing other provisions related thereto.**

*Motion by Council Member Hebblethwaite, second by Council Member Hatchett to approve Resolution No. 2026-08R as presented.

Roll call vote:

“Ayes:” Hatchett, Irving, Ginn, Hebblethwaite, Alexander, Southard, and Grayson.
“Nays:” None.
“Abstain:” None
Motion passed. 7-0

ITEM 3a. **Discussion, consideration, and possible action to approve Resolution No. 2026-09R; a RESOLUTION OF THE CITY COUNCIL OF THE CITY OF CHICKASHA, OKLAHOMA, AUTHORIZING THE CITY MANAGER TO COMMIT LOCAL MATCHING FUNDS FOR A FEDERAL EMERGENCY MANAGEMENT AGENCY EMERGENCY OPERATIONS CENTER GRANT APPLICATION.**

City Council Meeting 2-23-2026

6:00 p.m.

*Motion by Council Member Alexander, second by Council Member Hebblethwaite to approve Resolution No. 2026-09R as presented.

Roll call vote:

“Ayes:” Hatchett, Irving, Ginn, Hebblethwaite, Alexander, Southard, and Grayson.

“Nays:” None.

“Abstain:” None

Motion passed. 7-0

ITEM 4 Adjournment:

Motion by Council Member Alexander and second by Council Member Hatchett to adjourn the meeting.

Meeting adjourned.

TIME: 6:10 p.m.

Zachary Grayson, Mayor

ATTEST:

Susan M. McDaniel, City Clerk

Approved this 6th day of April 2026.

March 2, 2026

The **REGULAR** meeting of the **CHICKASHA CITY COUNCIL** was held in the council chambers in city hall on the 2nd day of March 2026 as specified by advance public notice with a properly prepared agenda stating the subject matter or matters to be discussed at said meeting. Mayor Grayson called the meeting to order at 6:30 p.m.

ITEM 1. Call to Order / Roll Call / Opening Prayer / Pledge of Allegiance

MAYOR AND COUNCIL

PRESENT: Zachary Grayson, Mayor
Georgianne Hebblethwaite, Vice-Mayor
Lisa Hatchett
Kim Irving
Kea Ginn
John Smith
Erica Alexander
Charlie Burruss
Clark Southard

ABSENT: None.

STAFF

PRESENT: Jim Crosby, City Manager
Amanda Mullins, City Attorney
Susan McDaniel, City Clerk
G. G. Music, Police Chief
Tony Samaniego, Fire Chief
Rich Edwards, Finance Director
Jessica Green, Community Development Director
Lillie Huckaby, Library Director
Shae Mortimer, Marketing and Civic Engagement Manager

ITEM 1. Call to Order/Roll Call/Opening Prayer/Pledge of Allegiance:

Roll call:

Hatchett – Present
Irving – Present
Ginn - Present
Hebblethwaite – Present

City Council Meeting 3-2-2026

6:30 p.m.

Smith – Present

Alexander - Present

Burruss – Present

Southard – Present

Grayson - Present

Council Member Burruss gave the invocation and Council Member Southard lead the Pledge of Allegiance.

ITEM 2. Citizen Comments:

(City Council Rules and Regulations limit visitor comments to a maximum of three minutes.)

Ryan Wood, Chickasha – Asked for consideration for speed bumps to be placed in his neighborhood for safety.

Kelly Boyd, Chickasha – commented about politics.

ITEM 3. Council Communications.

Council Member Southard asked that we keep our Armed Service men and women in your thoughts and support them.

ITEM 4. Consent Docket: ITEM 4a thru 4e.

ITEM 4a. Acceptance of the Minutes of February 16, 2026, Regular meeting; and the Minutes of February 23, 2026, Special meeting.

ITEM 4b. Accept Claims List.

ITEM 4c. Acceptance of Resolution 2026-10R amending the FY25/26 Budget.

ITEM 4d. Declare as surplus three Police Department Vehicles and dispose of in accordance with City Ordinance.

ITEM 4e. Acceptance of the Best Friends Animal Society Grant in the amount of \$2,000.00 to benefit the Chickasha Animal Shelter.

Motion by Council Member Alexander, second by Council Member Hatchett to approve Consent Docket Items 4a – 4e.

Roll call vote:

Ayes:” Hatchett, Irving, Ginn, Hebblethwaite, Smith, Alexander, Southard, and Grayson.

“Nays:” None

“Abstain:” Burruss

Motion carried. 8-0-1

ITEM 5. Discussion/Approval of Items Removed from Consent Docket:

NO ACTION TAKEN.

ITEM 6. **Discussion and Consideration Items:**

Council Member Burruss lease his seat at 6:39 p.m.

ITEM 6a. **Discussion, consideration, and possible action to approve a second Oil Well Drilling Permit for Camino Resources for Salt Plains 0707 20-29-31-1WXH well. This Well site being part of the SW/4-SW/4 Section 21, T7N-R7W, Grady County, Oklahoma, to be located within the City Limits.**

*Motion by Council Member Hebblethwaite, second by Council Member Alexander to approve a second Oil Well Drilling Permit for Camino Resources for Salt Plains 0707 20-29-32-1WXH well. This Well site being part of the SW/4-SW/4 Section 21, T7N-R7W, Grady County, Oklahoma, to be located within the City Limits.

Roll call vote:

“Ayes:” Hatchett, Irving, Ginn, Hebblethwaite, Smith, Alexander, Southard, and Grayson.
“Nays:” None.
“Abstain:” None
Motion passed. 8-0-0

ITEM 6b. **Discussion, consideration, and possible action to conduct a public auction pursuant to 64 O.S. Section 1081 and 1082 for the sale of oil and gas mining lease(s) covering the following real property:**
Tract 1: An undivided 80 acres, more or less, in the SE/4 of Section 10, Township 8 North, Range 9 West, Caddo County, Oklahoma.
Tract 2: An undivided 60 acres, more or less, in the N/2 NE/4 of Section 10, Township 8 North, Range 9 West, Caddo County, Oklahoma.
Tract 3: An undivided 80 acres, more or less, in the S/2 NE/4 of Section 10, Township 8 North, Range 9 West, Caddo County, Oklahoma.

*Motion by Council Member Hebblethwaite, second by Council Member Hatchett to conduct a public auction.

Roll call vote:

“Ayes:” Hatchett, Irving, Ginn, Hebblethwaite, Smith, Alexander, Southard, and Grayson.
“Nays:” None.
“Abstain:” None
Motion passed. 8-0

City Council Meeting 3-2-2026
6:30 p.m.

Tract 1: An undivided 80 acres, more or less, in the SE/4 of Section 10, Township 8 North, Range 9 West, Caddo County, Oklahoma.
Bid by Steven Welch, Jackfork Land on behalf of Continental Resources - \$1,700 per acre with 1/5 Royalties.

Tract 2: An undivided 60 acres, more or less, in the N/2 NE/4 of Section 10, Township 8 North, Range 9 West, Caddo County, Oklahoma.
Bid by Steven Welch, Jackfork Land on behalf of Continental Resources - \$1,700 per acre with 1/5 Royalties.

Tract 3: An undivided 80 acres, more or less, in the S/2 NE/4 of Section 10, Township 8 North, Range 9 West, Caddo County, Oklahoma.
Bid by Steven Welch, Jackfork Land on behalf of Continental Resources - \$1,700 per acre with 1/5 Royalties.

ITEM 6c. Discussion, consideration, and possible action to approve Resolution 2026-11R to authorize the publication of public sale and public auction pursuant to 64 O.S. Section 1081 and 1081 for oil and gas mining lease(s) for oil and gas development covering the real properties in Section 31 and 32, Township 7 North, Range 7 West, Grady County, Oklahoma and more specifically set forth in the Resolution.

*Motion by Council Member Hebblethwaite, second by Council Member Ginn to approve Resolution 2026-11R as presented.

Roll call vote:

“Ayes:”	Hatchett, Irving, Ginn, Hebblethwaite, Smith, Alexander, Southard, and Grayson.
“Nays:”	None.
“Abstain:”	None.
Motion passed.	8-0-0

Council Member Burruss returned to his seat at 6:58 p.m.

ITEM 6d. Discussion, consideration and possible action to approve and authorize execution of a Construction Contract with Wynn Construction Co., previously determined to be lowest and best bidder, for the Water Treatment Plant Improvement Project CMA-2303, and to approve and accept the accompanying Performance Bond, Payment Bond, and Maintenance Bond as required by the Oklahoma Public Competitive Bidding Act, 61 O.S. §§ 1 et seq.

City Council Meeting 3-2-2026
6:30 p.m.

*Motion by Council Member Alexander, second by Council Member Hatchett to approve and authorize execution of a Construction Contract with Wynn Construction Co., previously determined to be lowest and best bidder, for the Water Treatment Plant Improvement Project CMA-2303, and to approve and accept the accompanying Performance Bond, Payment Bond, and Maintenance Bond as required by the Oklahoma Public Competitive Bidding Act, 61 O.S. §§ 1 et seq.

Roll call vote:

“Ayes:” Hatchett, Irving, Ginn, Hebblethwaite, Smith, Alexander, Burruss, Southard, and Grayson.

“Nays:” None.

“Abstain:” None

Motion passed. 9-0

ITEM 6e. Discussion, consideration, and possible action to approve Task Authorization No. 4 with Freese and Nichols, Inc. for Construction Phase and Commissioning Services for the new 6.0 MGD Water Treatment Plant Improvement Project CMA-2303, pursuant to the existing Master Services Agreement, and to authorize execution thereof.

*Motion by Council Member Hebblethwaite, second by Council Member Hatchett to approve Task Authorization No. 4 with Freese and Nichols, Inc. for Construction Phase and Commissioning Services for the new 6.0 MGD Water Treatment Plant Improvement Project CMA-2303, pursuant to the existing Master Services Agreement, and to authorize execution thereof.

Roll call vote:

“Ayes:” Hatchett, Irving, Ginn, Hebblethwaite, Smith, Alexander, Burruss, Southard, and Grayson.

“Nays:” None

“Abstain:” None

Motion passed. 9-0

ITEM 6f. Discussion, consideration, and possible action to approve a renewal with Onward Fleet Solutions for GeoTab GPS tracking of city-owned vehicles in an approximate amount of \$25,000.00 and authorize the Mayor to execute the same.

*Motion by Council Member Alexander, second by Council Member Hebblethwaite to approve a renewal with Onward Fleet Solutions for GeoTab GPS tracking of city-owned vehicles in an approximate amount of \$25,000.00 and authorize the Mayor to execute the same.

Roll call vote:

6:30 p.m.

“Ayes:” Hatchett, Irving, Ginn, Hebblethwaite, Smith, Alexander, Burruss, Southard, and Grayson.
“Nays:” None
“Abstain:” None
Motion passed. 9-0

ITEM 6g. Discussion, consideration, and possible action to approve a temporary street closure of the 100-300 blocks of Chickasha Avenue for a fund-raising event titled “Downe Towne Motor Rally” on March 28, 2026, benefiting the Larry Muncrief & Daren Cook Foundation and the Tiny Hands, Hearts, and Souls Foundation and waive any associated fees.

*Motion by Council Member Burruss, second by Council Member Hatchett to approve a temporary street closure of the 100-300 blocks of Chickasha Avenue for a fund-raising event titled “Downe Towne Motor Rally” on March 28, 2026, benefiting the Larry Muncrief & Daren Cook Foundation and the Tiny Hands, Hearts, and Souls Foundation and waive any associated fees .

Roll call vote:

“Ayes:” Hatchett, Irving, Ginn, Hebblethwaite, Smith, Alexander, Burruss, Southard, and Grayson.
“Nays:” None
“Abstain:” None
Motion passed. 9-0

ITEM 6h. Discussion, consideration, and possible action to approve the appointment of Patricia Arthur to the Library Board to fill a vacant position with an unexpired term of June 30, 2027.

*Motion by Council Member Alexander, second by Council Member Hebblethwaite to approve the appointment of Patricia Arthur to the Library Board to fill a vacant position with an unexpired term of June 30, 2027.

Roll call vote:

“Ayes:” Hatchett, Irving, Ginn, Hebblethwaite, Smith, Alexander, Burruss, Southard, and Grayson.
“Nays:” None
“Abstain:” None
Motion passed. 9-0

ITEM 7 Executive Session:

Council Member Burruss left his seat at 6:54 p.m.

ITEM 7a. Discussion, consideration, and possible action to enter into executive session pursuant to Title 25 O.S. Section 307 (B) (3) to discuss the sale, purchase, lease, acquisition or appraisal of real property, in order to advise Council regarding acceptance of bid(s) following notice by publication of public sale and public auction pursuant to 64 O.S. Section 1081 and 1082 for the sale of oil and gas mining lease(s) covering the following real property:

Tract 1: An undivided 80 acres, more or less, in the SE/4 of Section 10, Township 8 North, Range 9 West, Caddo County, Oklahoma.

Tract 2: An undivided 60 acres, more or less, in the N/2 NE/4 of Section 10, Township 8 North, Range 9 West, Caddo County, Oklahoma.

Tract 3: An undivided 80 acres, more or less, in the S/2 NE/4 of Section 10, Township 8 North, Range 9 West, Caddo County, Oklahoma.

*Motion by Council Member Southard, second by Council Member Hatchett to enter into executive session.

Roll call vote:

“Ayes:” Hatchett, Irving, Ginn, Hebblethwaite, Smith, Alexander, Southard, and Grayson.

“Nays:” None.

“Abstain:” None

Motion passed. 8-0

ITEM 7b. Vote to Reconvene Open Session.

*Motion by Council Member Alexander, second by Council Member Hatchett to reconvene open session.

Roll call vote:

“Ayes:” Hatchett, Irving, Ginn, Hebblethwaite, Smith, Alexander, Southard, and Grayson.

“Nays:” None.

“Abstain:” None

Motion passed. 8-0

ITEM 7c. Discussion, consideration, and possible action on any matter discussed in executive session pursuant to Title 25 O.S. Section 307 (B) (3) regarding the sale, purchase, lease, acquisition or appraisal of real property, including possible acceptance or rejection of bids received

for sale of oil and gas mining lease(s) covering the following described properties:

Tract 1: An undivided 80 acres, more or less, in the SE/4 of Section 10, Township 8 North, Range 9 West, Caddo County, Oklahoma.

Motion by Alexander, Second by Hebblethwaite to accept the bid from Steve Welch, Jackfork Land on behalf of Continental Resources of \$1,700.00 per acre and 1/5 royalties.

Roll call vote:

“Ayes:” Hatchett, Irving, Ginn, Hebblethwaite, Smith, Alexander, Southard, and Grayson.
“Nays:” None.
“Abstain:” None
Motion passed. 8-0

Tract 2: An undivided 60 acres, more or less, in the N/2 NE/4 of Section 10, Township 8 North, Range 9 West, Caddo County, Oklahoma.

Motion by Alexander, Second by Hatchett to accept the bid from Steve Welch, Jackfork Land on behalf of Continental Resources of \$1,700.00 per acre and 1/5 royalties.

Roll call vote:

“Ayes:” Hatchett, Irving, Ginn, Hebblethwaite, Smith, Alexander, Southard, and Grayson.
“Nays:” None.
“Abstain:” None
Motion passed. 8-0

Tract 3: An undivided 80 acres, more or less, in the S/2 NE/4 of Section 10, Township 8 North, Range 9 West, Caddo County, Oklahoma.

Motion by Alexander, Second by Hatchett to accept the bid from Steve Welch, Jackfork Land on behalf of Continental Resources of \$1,700.00 per acre and 1/5 royalties.

Roll call vote:

“Ayes:” Hatchett, Irving, Ginn, Hebblethwaite, Smith, Alexander, Southard, and Grayson.
“Nays:” None.

City Council Meeting 3-2-2026
6:30 p.m.

“Abstain:” None
Motion passed. 8-0

ITEM 8 Adjournment:

Motion by Council Member Hatchett and second by Council Member Hebblethwaite to adjourn the meeting.

Meeting adjourned.

TIME: 7:02 p.m.

Zachary Grayson, Mayor

ATTEST:

Susan M. McDaniel, City Clerk

Approved this 6th day of April 2026.

March 23, 2026

The **SPECIAL** meeting of the **CHICKASHA CITY COUNCIL** was held in the council chambers in city hall on the 23rd day of March 2026 as specified by advance public notice with a properly prepared agenda stating the subject matter or matters to be discussed at said meeting. Mayor Grayson called the meeting to order at 6:30 p.m.

ITEM 1. **Call to Order / Roll Call**

MAYOR AND COUNCIL

PRESENT: Zachary Grayson, Mayor
 Georgianne Hebblethwaite, Vice-Mayor
 Lisa Hatchett
 Kim Irving
 Kea Ginn – arrived at 6:33 p.m.
 John Smith
 Erica Alexander
 Charlie Burruss
 Clark Southard

ABSENT: None.

STAFF

PRESENT: Jim Crosby, City Manager
 Susan McDaniel, City Clerk
 Rich Edwards, Finance Director
 Jessica Green, Community Development Director
 Omar Fierro, Public Works Director
 Andy Conyers, Parks & Rec Director
 Shae Mortimer, Marketing and Civic Engagement Manager

ITEM 1. **Call to Order/Roll Call:**

Roll call:

Hatchett – Present
Irving – Present
Hebblethwaite – Present
Smith – Present
Alexander - Present
Burruss – Present

City Council Meeting 3-23-2026

6:30 p.m.

Southard - Present

Grayson - Present

ITEM 2. **Consent Docket:**

ITEM 2a. **Acceptance of the Claims List.**

Motion by Council Member Alexander, second by Council Member Hebblethwaite.

Roll call vote:

Ayes:” Hatchett, Irving, Ginn, Hebblethwaite, Smith, Alexander, Burruss,
Southard, and Grayson.

“Nays:” None

“Abstain:” None

Motion carried. 9-0

ITEM 3. **Discussion and Consideration Items:**

ITEM 3a. **Discussion, consideration, and possible action to approve Task Order No. 02 – Water Line and Sewer Line Extension Chickasha Municipal Airport with Parkhill for an amount not to exceed \$249,000.00 and authorize the Mayor to execute the same.**

*Motion by Council Member Hebblethwaite, second by Council Member Hatchett to approve Task Order No. 2 – Water Line and Sewer Line Extension Chickasha Municipal Airport with Parkhill for an amount not to exceed \$249,000.00 and authorize the Mayor to execute the same.

Roll call vote:

“Ayes:” Hatchett, Irving, Ginn, Hebblethwaite, Smith, Alexander, Burruss,
Southard, and Grayson.

“Nays:” None.

“Abstain:” None

Motion passed. 9-0

ITEM 4 **Adjournment:**

Motion by Council Member Alexander and second by Council Member Hebblethwaite to adjourn the meeting.

Meeting adjourned.

TIME: 6:35 p.m.

City Council Meeting 3-23-2026
6:30 p.m.

Zachary Grayson, Mayor

ATTEST:

Susan M. McDaniel, City Clerk

Approved this 6th day of April 2026.

CHICKASHA

Meeting Type: Council Agenda 4-6-2026

Meeting Date: 4/6/2026

Department: Finance

Agenda Item No. 4.b.

AGENDA ITEM: Acceptance of the Claims List.

I. BACKGROUND/DESCRIPTION:

II. RECOMMENDED ACTION:

Accept of the Claims List.

III. FISCAL INFORMATION -

IV. FUND INFORMATION:

Dept. Director: Rich Edwards, Finance Director	Fund	Account	Amount
	(To)		
	FUND	ACCOUNT	AMOUNT
Meeting Date: April 6, 2026	(From)		

V. ATTACHMENTS:

1. AP Council Report - 8971_Redacted

DEPARTMENT	FUND	VENDOR NAME	DESCRIPTION	AMOUNT		
NON-DEPARTMENTAL	GENERAL FUND	MISC ONE-TIME V OKIE SOLAR	MECHANICAL PERMIT REFUND	59.50		
			ARIZONA SOLAR SOLUTION	FEE REFUND - ARIZONA SOLA	377.55	
		WASHINGTON NATIONAL INS. CO	LISSA CALLAHAN	OCCUPANCY PERMIT REFUND	44.00	
			WASHINGTON NATIONAL INS. CO	WASHINGTON NATIONAL INS. C	0.15-	
		BLUE CROSS BLUE SHIELD OF OKLAHOMA 202	THE STANDARD INSURANCE COMPANY	BLUE CROSS BLUE SHIELD OF	6,198.19	
			THE STANDARD INSURANCE COMPANY	THE STANDARD INSURANCE COM	118.33	
		OPTIONS COUNSELING SERVICE, INC.	OPTIONS COUNSELING SERVICE	1.50		
		IAFF LOCAL 2041 (HEALTH INS)	IAFF LOCAL 2041 (HEALTH IN	1,005.00		
			TOTAL:	7,803.92		
		ADMINISTRATION	GENERAL FUND	OPTIMUM	114505X04102025	65.44
BLUE CROSS BLUE SHIELD OF OKLAHOMA 202	MED \$1,000 DED EMP ONLY				200.32	
	MED \$1,000 DED EMP ONLY			200.32		
	MED \$1,000 DED EMP/SPOUSE			485.15		
	MED \$1,000 DED EMP/SPOUSE			485.15		
	MED \$2,500 DED EMP ONLY			198.17		
	MED \$2,500 DED EMP ONLY			198.17		
	MED \$2,500 DED EMP/FAMILY			660.11		
	MED \$2,500 DED EMP/FAMILY			660.11		
COMMERCIAL CLEANING-SOLUTIONS, LLC	CH - CLEANING SERVICES			2,080.00		
	CITY WIDE - WINDOW CLEAN			726.00		
OKLAHOMA MUNICIPAL RETIRE	OMRF3			492.31		
	OMRF			862.10		
	OMRF			852.82		
CINTAS CORP	CLEANING SUPPLIES FOR CH			232.41		
	CLEANING SUPPLIES FOR CH			70.00		
	CLEANING SUPPLIES FOR CH			74.97		
TRANSFER ACCOUNT	FICA			879.01		
	MEDICARE			205.57		
JOURNAL RECORD	PUBLISH CMA-2601			96.74		
	OPTIONS COUNSELING SERVICE, INC.			EMPLOYEE ASSISTANCE PROGRA	6.00	
	EMPLOYEE ASSISTANCE PROGRA			6.00		
	TOTAL:			9,736.87		
FIRE ADMINISTRATION	GENERAL FUND			OPTIMUM	FD 2 TV SERVICES FEB26	222.58
					FD 1 INTERNET/TV MAR26	327.28
				BLUE CROSS BLUE SHIELD OF OKLAHOMA 202	MED \$1,000 DED EMP ONLY	251.17
					MED \$1,000 DED EMP ONLY	251.17
		MED \$1,000 DED EMP/FAM	1,334.54			
		MED \$1,000 DED EMP/FAM	1,334.54			
		OSDH EMERGENCY SYSTEMS	EMT RENEWAL - BLUE	22.50		
			DAUGHTERY & MCCOMBS RENEW	65.00		
			PEYTON/TOMKINS PARA RENEW	65.00		
		OKLAHOMA FIREFIGHTERS	FIRE PENSION	1,088.29		
			OKLAHOMA MUNICIPAL RETIRE	OMRF	127.32	
			OMRF	128.87		
		SUMMIT UTILITIES	COMBINED ACCT 22010002900	69.34		
			COMBINED ACC 22010000290	1,421.04		
		TRANSFER ACCOUNT	FICA	72.29		
			MEDICARE	117.49		
		OPTIONS COUNSELING SERVICE, INC.	EMPLOYEE ASSISTANCE PROGRA	4.50		
			EMPLOYEE ASSISTANCE PROGRA	4.50		
		IAFF LOCAL 2041 (HEALTH INS)	FIRE EE/SPOUSE DENTAL	139.20		
			FIRE EE/SPOUSE DENTAL	133.44		
FIRE GROUP LIFE	22.80					
FIRE GROUP LIFE	22.56					

DEPARTMENT	FUND	VENDOR NAME	DESCRIPTION	AMOUNT
			FIR/EESP VISION	72.00
			FIR/EESP VISION	<u>69.02</u>
			TOTAL:	7,366.44
POLICE ADMINISTRATION	GENERAL FUND	BLUE CROSS BLUE SHIELD OF OKLAHOMA 202	MED \$2,500 DED EMP ONLY	396.34
			MED \$2,500 DED EMP ONLY	396.34
			MED \$2,500 DED EMP/FAMILY	660.11
			MED \$2,500 DED EMP/FAMILY	660.11
			MED #2,500 DED EMP/SPOUSE	479.95
			MED #2,500 DED EMP/SPOUSE	479.95
		COMMERCIAL CLEANING-SOLUTIONS, LLC	PD - CLEANING SERVICES	1,225.00
			PD - STRIP AND WAX	490.00
		CITY OF CHICKASHA-(ACH) OKLAHOMA POLIC	POLICE PENSION	1,222.20
		OKLAHOMA MUNICIPAL RETIRE	OMRF	358.42
			OMRF	377.09
		SUMMIT UTILITIES	COMBINED ACCT 22010002900	670.90
		TRANSFER ACCOUNT	FICA	728.16
			MEDICARE	170.29
		UNIFIRST HOLDINGS, L.P.	SUPPLIES AND UNIFORMS	18.79
			SUPPLIES AND UNIFORMS	18.79
		OPTIONS COUNSELING SERVICE, INC.	EMPLOYEE ASSISTANCE PROGRA	6.00
			EMPLOYEE ASSISTANCE PROGRA	<u>6.00</u>
			TOTAL:	8,364.44
EMERGENCY MANAGEMENT	GENERAL FUND	PUBLIC SERVICE COMPANY OF OKLAHOMA	CITY ELECT SERV. JAN-JUN	5.35
		OKLAHOMA MUNICIPAL RETIRE	OMRF	366.23
			OMRF	366.23
		TRANSFER ACCOUNT	FICA	214.61
			MEDICARE	50.19
		OPTIONS COUNSELING SERVICE, INC.	EMPLOYEE ASSISTANCE PROGRA	1.50
			EMPLOYEE ASSISTANCE PROGRA	<u>1.50</u>
			TOTAL:	1,005.61
CEMETERY SERVICES	GENERAL FUND	BLUE CROSS BLUE SHIELD OF OKLAHOMA 202	MED \$1,000 DED EMP ONLY	400.64-
		OKLAHOMA MUNICIPAL RETIRE	OMRF	897.77
			OMRF	173.82
		SMALL ENGINE SERVICE	MICELLANEOUS ITEMS	37.15
			MICELLANEOUS ITEMS	532.56
		TRANSFER ACCOUNT	FICA	145.40
			MEDICARE	34.01
		UNIFIRST HOLDINGS, L.P.	CEMETERY TEMPS	75.61
			CEMETERY TEMPS	33.23
		OPTIONS COUNSELING SERVICE, INC.	EMPLOYEE ASSISTANCE PROGRA	3.00
			EMPLOYEE ASSISTANCE PROGRA	<u>3.00</u>
			TOTAL:	1,534.91
HUMAN RESOURCES	GENERAL FUND	BLUE CROSS BLUE SHIELD OF OKLAHOMA 202	MED \$2,500 DED EMP ONLY	396.34
			MED \$2,500 DED EMP ONLY	396.34
		OKLAHOMA MUNICIPAL RETIRE	OMRF	553.04
			OMRF	551.90
		TRANSFER ACCOUNT	FICA	324.22
			MEDICARE	75.83
		OPTIONS COUNSELING SERVICE, INC.	EMPLOYEE ASSISTANCE PROGRA	3.00
			EMPLOYEE ASSISTANCE PROGRA	<u>3.00</u>
			TOTAL:	2,303.67

DEPARTMENT	FUND	VENDOR NAME	DESCRIPTION	AMOUNT		
LIBRARY	GENERAL FUND	OVERDRIVE	E-BOOK CONTENT	800.00		
		BLUE CROSS BLUE SHIELD OF OKLAHOMA 202	MED \$1,000 DED EMP ONLY	1,303.62		
			MED \$1,000 DED EMP ONLY	1,303.62		
			MED \$2,500 DED EMP ONLY	198.17		
			MED \$2,500 DED EMP ONLY	198.17		
		COMMERCIAL CLEANING-SOLUTIONS, LLC	LIBRARY - CLEANING SERVIC	1,722.00		
		OKLAHOMA MUNICIPAL RETIRE	OMRF	1,239.39		
			OMRF	1,242.24		
		SUMMIT UTILITIES	COMBINED ACCT 22010002900	1,121.22		
		TRANSFER ACCOUNT	FICA	708.61		
			MEDICARE	165.73		
		OPTIONS COUNSELING SERVICE, INC.	EMPLOYEE ASSISTANCE PROGRA	10.50		
			EMPLOYEE ASSISTANCE PROGRA	10.50		
			TOTAL:	10,023.77		
		STREET & STORM DRAINAG GENERAL FUND		HERC RENTALS CHICKASHA	EQUIPMENT RENTAL	521.44
				CHICKASHA INDUSTRIAL & WE	WELDING SUPPLIES	88.16
					WELDING SUPPLIES	305.73
					WELDING SUPPLIES	49.29
					WELDING SUPPLIES	24.48
					SAFETY EQUIPMENT	37.40
	SAFETY EQUIPMENT			381.62		
MARSHALL AUTO PARTS	REPAIR PARTS			4.90		
	REPAIR PARTS			52.76		
	REPAIR PARTS			11.79		
BLUE CROSS BLUE SHIELD OF OKLAHOMA 202	MED \$1,000 DED EMP ONLY			200.32		
	MED \$1,000 DED EMP ONLY			200.32		
	MED #2,500 DED EMP/SPOUSE			959.90		
	MED #2,500 DED EMP/SPOUSE			959.90		
K&K SYSTEMS, INC	FLASHING CROSS WALK SIGNS			10,937.38		
OKLAHOMA MUNICIPAL RETIRE	OMRF			1,203.31		
	OMRF			1,173.56		
C L BOYD	QUICK QOUPLER			1,512.06		
TRANSFER ACCOUNT	FICA			654.91		
	MEDICARE			153.17		
UNIFIRST HOLDINGS, L.P.	DEC25-JAN26 CLEANING/UNIF			250.63		
	DEC25-JAN26 CLEANING/UNIF			187.51		
OPTIONS COUNSELING SERVICE, INC.	EMPLOYEE ASSISTANCE PROGRA			10.50		
	EMPLOYEE ASSISTANCE PROGRA			10.50		
DOLESE BROS CO	1R9R-G69H-96V6			795.00		
	1R9R-G69H-96V6			2,385.00		
	1R9R-G69H-96V6			2,385.00		
	TOTAL:			25,456.54		
FLEET MAINTENANCE	GENERAL FUND			BLUE CROSS BLUE SHIELD OF OKLAHOMA 202	MED \$1,000 DED EMP/SPOUSE	485.15
					MED \$1,000 DED EMP/SPOUSE	485.15
			MED \$2,500 DED EMP ONLY	198.17		
			MED \$2,500 DED EMP ONLY	198.17		
		OKLAHOMA MUNICIPAL RETIRE	OMRF	359.61		
			OMRF	412.42		
		TRANSFER ACCOUNT	FICA	216.79		
			MEDICARE	50.70		
		OPTIONS COUNSELING SERVICE, INC.	EMPLOYEE ASSISTANCE PROGRA	3.00		
			EMPLOYEE ASSISTANCE PROGRA	3.00		
			TOTAL:	2,412.16		

DEPARTMENT	FUND	VENDOR NAME	DESCRIPTION	AMOUNT		
ACCOUNTING SERVICES	GENERAL FUND	BLUE CROSS BLUE SHIELD OF OKLAHOMA 202	MED \$2,500 DED EMP ONLY	396.34		
			MED \$2,500 DED EMP ONLY	396.34		
			MED \$2,500 DED EMP/FAMILY	660.11		
			MED \$2,500 DED EMP/FAMILY	660.11		
		OKLAHOMA MUNICIPAL RETIRE	OMRF	980.62		
			OMRF	1,100.63		
		CULLIGAN	CH WATER DEL MAR26	49.75		
			FICA	729.66		
		TRANSFER ACCOUNT	MEDICARE	170.64		
			PROF SERVICES OCT-NOV 25	14,117.50		
		CRAWFORD AND ASSOCIATES PC	EMPLOYEE ASSISTANCE PROGRA	6.00		
			EMPLOYEE ASSISTANCE PROGRA	<u>6.00</u>		
		OPTIONS COUNSELING SERVICE, INC.	TOTAL:	19,273.70		
		COMM DEVEL/PLANNING SE	GENERAL FUND	BLUE CROSS BLUE SHIELD OF OKLAHOMA 202	MED \$1,000 DED EMP ONLY	251.17
MED \$1,000 DED EMP ONLY	251.17-					
MED \$2,500 DED EMP/CHILD	358.68					
MED \$2,500 DED EMP/CHILD	358.68					
OKLAHOMA MUNICIPAL RETIRE	OMRF			717.91		
	OMRF			721.41		
TRANSFER ACCOUNT	FICA			427.62		
	MEDICARE			100.00		
OPTIONS COUNSELING SERVICE, INC.	EMPLOYEE ASSISTANCE PROGRA			4.50		
	EMPLOYEE ASSISTANCE PROGRA			<u>4.50</u>		
	TOTAL:			2,693.30		
GENERAL GOVERNMENT	GENERAL FUND			IRON MOUNTAIN INC. CHAFFIN, MICHAEL R. QUADIENT LEASING USA, INC CHICKASHA DEVELOPMENT COMPANY LLC COALIGN GROUP LLC CANADIAN VALLEY TECH CNT OMAG	SHREDDING SERVICES C.H.	174.06
					APR 2026 JUDGE PAYMENT	1,800.00
					LEASE SERVICE 03/21-04/21	300.06
		2025 SALES TAX REBATE	108,079.63			
		CONSULTING FEES	5,000.00			
		SAFETY TRAINING	100.00			
		GEN LIAB/AUTO 3RDINS. PMT	62,062.25			
		PROPERTY INS-3RDQRTLY PMT	<u>54,384.75</u>			
		TOTAL:	231,900.75			
BUILDING SERVICES	GENERAL FUND	BLUE CROSS BLUE SHIELD OF OKLAHOMA 202	MED \$2,500 DED EMP/CHILD	358.68		
			MED \$2,500 DED EMP/CHILD	358.68		
			MED \$2,500 DED EMP ONLY	198.17		
			MED \$2,500 DED EMP ONLY	198.17		
		HUDSON PRINCE ENGINEERING & INSPECTION	ENGINEERING FEE WO 10	895.00		
			ENGINEERING FEE WO 10	665.00		
		OKLAHOMA MUNICIPAL RETIRE	OMRF	603.22		
			OMRF	610.85		
		TRANSFER ACCOUNT	FICA	345.07		
			MEDICARE	80.71		
		OPTIONS COUNSELING SERVICE, INC.	EMPLOYEE ASSISTANCE PROGRA	3.00		
EMPLOYEE ASSISTANCE PROGRA	<u>3.00</u>					
	TOTAL:	4,319.55				
FIRE OPERATIONS	GENERAL FUND	OSU FIRE SERVICE TRAINING OKLAHOMA FIREFIGHTERS TRANSFER ACCOUNT OPTIONS COUNSELING SERVICE, INC. IAFF LOCAL 2041 (HEALTH INS)	STAFF TRAINING 01/27/26	1,050.00		
			FIRE PENSION	11,288.52		
			MEDICARE	1,252.76		
			EMPLOYEE ASSISTANCE PROGRA	36.00		
			EMPLOYEE ASSISTANCE PROGRA	35.62		
			FIR/EECH OPTION A	2,604.00		

DEPARTMENT	FUND	VENDOR NAME	DESCRIPTION	AMOUNT
			FIR/EECH OPTION A	2,083.20
			FIRE EE/CHILD(REN) DENTAL	124.80
			FIRE EE/CHILD(REN) DENTAL	104.00
			FIRE EE DENTAL	16.00
			FIRE EE DENTAL	16.00
			FIRE FAMILY DENTAL	365.20
			FIRE FAMILY DENTAL	398.40
			FIR/FAM OPTION A	8,720.80
			FIR/FAM OPTION A	9,513.60
			FIR/FAM OPTION B	716.00
			FIR/FAM OPTION B	716.00
			FIR/FAM OPTION D	585.20
			FIR/FAM OPTION D	585.20
			FIR/EESP OPTION A	2,924.00
			FIR/EESP OPTION A	2,778.70
			FIRE/EES OPTION C	440.80
			FIRE/EES OPTION C	440.80
			FIR/EE/CH VISION	56.00
			FIR/EE/CH VISION	56.00
			FIR/EE VISION	7.20
			FIR/EE VISION	7.20
			FIR/FAM VISION	211.20
			FIR/FAM VISION	211.20
			TOTAL:	47,344.40
PATROL SERVICES	GENERAL FUND	SCOTT ELY	REIMBURSEMENT	93.70
		BLUE CROSS BLUE SHIELD OF OKLAHOMA 202	MED \$1,000 DED EMP/CHILD	725.14
			MED \$1,000 DED EMP/CHILD	725.14
			MED \$1,000 DED EMP ONLY	1,001.60
			MED \$1,000 DED EMP ONLY	1,001.60
			MED \$1,000 DED EMP/FAM	667.27
			MED \$1,000 DED EMP/FAM	667.27
			MED \$1,000 DED EMP/SPOUSE	485.15
			MED \$1,000 DED EMP/SPOUSE	485.15
			MED \$2,500 DED EMP/CHILD	358.68
			MED \$2,500 DED EMP/CHILD	358.68
			MED \$2,500 DED EMP ONLY	198.17
			MED \$2,500 DED EMP ONLY	198.17
			MED \$2,500 DED EMP/FAMILY	2,640.44
			MED \$2,500 DED EMP/FAMILY	2,640.44
		VALOR DEFENSE DEPOT, LLC	2 NEW VEST	2,672.04
			AMMO	2,118.70
		HARDWIRED INTEGRATED TRAINING SOLUTION	FIREARMS TRAINING	600.00
		CITY OF CHICKASHA-(ACH) OKLAHOMA POLIC	POLICE PENSION	6,762.74
		TRANSFER ACCOUNT	FICA	3,228.13
			MEDICARE	754.99
		OPTIONS COUNSELING SERVICE, INC.	EMPLOYEE ASSISTANCE PROGRA	30.00
			EMPLOYEE ASSISTANCE PROGRA	30.00
		PRO AUTO CARE	REPAIRS - UNIT #6626	5,188.84
			TOTAL:	33,632.04
INVESTIGATIONS	GENERAL FUND	BLUE CROSS BLUE SHIELD OF OKLAHOMA 202	MED \$1,000 DED EMP/CHILD	362.57
			MED \$1,000 DED EMP/CHILD	362.57
			MED \$2,500 DED EMP/FAMILY	1,320.22
			MED \$2,500 DED EMP/FAMILY	1,320.22
		CITY OF CHICKASHA-(ACH) OKLAHOMA POLIC	POLICE PENSION	1,338.61

DEPARTMENT	FUND	VENDOR NAME	DESCRIPTION	AMOUNT
		TRANSFER ACCOUNT	FICA	597.39
			MEDICARE	139.71
		OPTIONS COUNSELING SERVICE, INC.	EMPLOYEE ASSISTANCE PROGRA	4.50
			EMPLOYEE ASSISTANCE PROGRA	<u>4.50</u>
			TOTAL:	5,450.29
ANIMAL CONTROL	GENERAL FUND	BLUE CROSS BLUE SHIELD OF OKLAHOMA 202	MED \$2,500 DED EMP/CHILD	358.68
			MED \$2,500 DED EMP/CHILD	358.68
			MED \$2,500 DED EMP ONLY	198.17
			MED \$2,500 DED EMP ONLY	198.17
		OKLAHOMA MUNICIPAL RETIRE	OMRF	552.88
			OMRF	575.05
		SUMMIT UTILITIES	COMBINED ACC 220100002901	257.31
		TRANSFER ACCOUNT	FICA	299.02
			MEDICARE	69.93
		OPTIONS COUNSELING SERVICE, INC.	EMPLOYEE ASSISTANCE PROGRA	4.50
			EMPLOYEE ASSISTANCE PROGRA	<u>4.50</u>
			TOTAL:	2,876.89
MUNICIPAL COURT	GENERAL FUND	BLUE CROSS BLUE SHIELD OF OKLAHOMA 202	MED \$1,000 DED EMP/SPOUSE	485.15
			MED \$1,000 DED EMP/SPOUSE	485.15
		OKLAHOMA MUNICIPAL RETIRE	OMRF	213.88
			OMRF	238.42
		TRANSFER ACCOUNT	FICA	112.89
			MEDICARE	26.40
		OPTIONS COUNSELING SERVICE, INC.	EMPLOYEE ASSISTANCE PROGRA	1.50
			EMPLOYEE ASSISTANCE PROGRA	<u>1.50</u>
			TOTAL:	1,564.89
DISPATCH SERVICES	GENERAL FUND	BLUE CROSS BLUE SHIELD OF OKLAHOMA 202	MED \$1,000 DED EMP ONLY	400.64
			MED \$1,000 DED EMP ONLY	400.64
			MED \$1,000 DED EMP/FAM	828.24
			MED \$1,000 DED EMP/FAM	828.24
			MED \$2,500 DED EMP ONLY	396.34
		OKLAHOMA MUNICIPAL RETIRE	OMRF	1,364.79
			OMRF	1,307.67
		TRANSFER ACCOUNT	FICA	732.63
			MEDICARE	171.33
		OPTIONS COUNSELING SERVICE, INC.	EMPLOYEE ASSISTANCE PROGRA	10.50
			EMPLOYEE ASSISTANCE PROGRA	<u>10.50</u>
			TOTAL:	6,451.52
CODE COMPLIANCE	GENERAL FUND	THE NORMAN TRANSCRIPT	CODE ENFORCEMENT PUBLISH	79.14
			CODE ENFORCEMENT PUBLISH	80.90
			FINDINGS OF FACT	140.08
		BLUE CROSS BLUE SHIELD OF OKLAHOMA 202	MED \$2,500 DED EMP ONLY	198.17
			MED \$2,500 DED EMP ONLY	198.17
		OKLAHOMA MUNICIPAL RETIRE	OMRF	335.97
			OMRF	357.25
		TRANSFER ACCOUNT	FICA	204.21
			MEDICARE	47.76
		OPTIONS COUNSELING SERVICE, INC.	EMPLOYEE ASSISTANCE PROGRA	3.00
			EMPLOYEE ASSISTANCE PROGRA	<u>3.00</u>
			TOTAL:	1,647.65
PARK MAINTENANCE	GENERAL FUND	AT&T MOBILITY	03/13 - 04/12 26 P&R TAB	54.00

DEPARTMENT	FUND	VENDOR NAME	DESCRIPTION	AMOUNT
		BLUE CROSS BLUE SHIELD OF OKLAHOMA 202	MED \$1,000 DED EMP ONLY	200.32
			MED \$1,000 DED EMP ONLY	200.32
			MED \$2,500 DED EMP/CHILD	358.68
			MED \$2,500 DED EMP/CHILD	358.68
			MED \$2,500 DED EMP ONLY	198.17
			MED \$2,500 DED EMP ONLY	198.17
		OKLAHOMA MUNICIPAL RETIRE	OMRF	899.66
			OMRF	1,231.97
		SUMMIT UTILITIES	COMBINED ACCT 22010002900	190.48
			COMBINED ACC 220100002901	429.71
		TRANSFER ACCOUNT	FICA	654.17
			MEDICARE	152.99
		ALERT 360	APRIL MONITORING	259.28
		EXPRESS TIRE BRAKE & ALIG	PM TRACTOR TIRE	309.00
		UNIFIRST HOLDINGS, L.P.	DEC25-JAN26 CLEANING/UNIF	110.90
			DEC25-JAN26 CLEANING/UNIF	161.77
		OPTIONS COUNSELING SERVICE, INC.	EMPLOYEE ASSISTANCE PROGRA	6.00
			EMPLOYEE ASSISTANCE PROGRA	7.50
		AT&T	PUBLIC POOL EMERGENCY LIN	705.50
			TOTAL:	6,687.27
SPORTS COMPLEX	GENERAL FUND	OKLAHOMA MUNICIPAL RETIRE	OMRF	155.84
			OMRF	224.31
		SUMMIT UTILITIES	COMBINED ACC 220100002901	670.12
		TRANSFER ACCOUNT	FICA	94.71
			MEDICARE	22.15
		OPTIONS COUNSELING SERVICE, INC.	EMPLOYEE ASSISTANCE PROGRA	1.50
			EMPLOYEE ASSISTANCE PROGRA	1.50
			TOTAL:	1,170.13
EMERGENCY MEDICAL SERV	EMERGENCY MED SERV	AT&T MOBILITY	EMS HOTSPOTS JAN-JUN26	91.50
		T-MOBILE USA INC	FD HOTSPOTS 02/21-03/20	219.45
		OKLAHOMA FIREFIGHTERS	FIRE PENSION	5,515.97
		TRANSFER ACCOUNT	MEDICARE	697.56
		OPTIONS COUNSELING SERVICE, INC.	EMPLOYEE ASSISTANCE PROGRA	27.00
			EMPLOYEE ASSISTANCE PROGRA	27.38
		IAFF LOCAL 2041 (HEALTH INS)	FIR/EECH OPTION A	520.80
			FIR/EECH OPTION A	520.80
			FIR/EEC OPTION D	326.80
			FIR/EEC OPTION D	326.80
			FIRE EE/CHILD(REN) DENTAL	41.60
			FIRE EE/CHILD(REN) DENTAL	41.60
			FIRE EE DENTAL	112.00
			FIRE EE DENTAL	112.00
			FIRE FAMILY DENTAL	66.40
			FIRE FAMILY DENTAL	66.40
			FIRE EE/SPOUSE DENTAL	69.60
			FIRE EE/SPOUSE DENTAL	75.36
			FIR/EE OPTION A	902.40
			FIR/EE OPTION A	902.40
			FIR/EE OPTION B	277.20
			FIR/EE OPTION B	277.20
			FIRE/EEC OPTION C	502.40
			FIRE/EEC OPTION C	502.40
			FIR/FAM OPTION A	1,585.60
			FIR/FAM OPTION A	1,585.60

DEPARTMENT	FUND	VENDOR NAME	DESCRIPTION	AMOUNT
			FIR/FAM OPTION D	585.20
			FIR/FAM OPTION D	585.20
			FIRE GROUP LIFE	15.20
			FIRE GROUP LIFE	15.44
			FIRE/EE OPTION D	223.60
			FIRE/EE OPTION D	223.60
			FIR/EESP OPTION A	1,754.40
			FIR/EESP OPTION A	1,899.70
			FIR/EE/CH VISION	22.40
			FIR/EE/CH VISION	22.40
			FIR/EE VISION	36.00
			FIR/EE VISION	36.00
			FIR/FAM VISION	17.60
			FIR/FAM VISION	17.60
			FIR/EESP VISION	48.00
			FIR/EESP VISION	<u>50.98</u>
			TOTAL:	20,947.54
UTILITY BILLING	CHICKASHA MUNICIPA	AMERICAN MUNICIPAL SERVICES	AMS FEES	130.00
		MATRIX / DATAPROSE	CHARTER AMENDMENT	751.85
		OKLAHOMA MUNICIPAL RETIRE	OMRF	612.80
			OMRF	606.51
		TRANSFER ACCOUNT	FICA	350.82
			MEDICARE	82.05
		OPTIONS COUNSELING SERVICE, INC.	EMPLOYEE ASSISTANCE PROGRA	4.50
			EMPLOYEE ASSISTANCE PROGRA	<u>4.50</u>
			TOTAL:	2,543.03
CMMA - CAPITAL PROJECTS	CHICKASHA MUNICIPA	OKLAHOMA CONTRACTORS SUPP	METER BOX AND LIDS	3,840.00
			WATER LINE PARTS	3,020.00
		LOCKE SUPPLY CO.	PARTS FOR WATER LINES	5.57
		TULSA WINWATER CO	WATER LINE PARTS	5,478.64
			WATER LINE PARTS	3,686.81
			WATER LINE PARTS	3,450.40
			WATER LINE PARTS	<u>834.59</u>
			TOTAL:	20,316.01
PUBLIC WORKS ADMIN	CHICKASHA MUNICIPA	FIRST CHOICE COFFEE SERVICES	COFFEE SUPPLIES	133.10
		BLUE CROSS BLUE SHIELD OF OKLAHOMA 202	MED \$1,000 DED EMP/FAM	667.27
			MED \$1,000 DED EMP/FAM	667.27
			MED \$2,500 DED EMP ONLY	198.17
			MED \$2,500 DED EMP ONLY	198.17
		OKLAHOMA MUNICIPAL RETIRE	OMRF	652.32
			OMRF	652.32
		TRANSFER ACCOUNT	FICA	294.58
			MEDICARE	68.89
		OPTIONS COUNSELING SERVICE, INC.	EMPLOYEE ASSISTANCE PROGRA	3.00
			EMPLOYEE ASSISTANCE PROGRA	<u>3.00</u>
			TOTAL:	3,141.75
SANITATION DEPARTMENT	CHICKASHA MUNICIPA	BLUE CROSS BLUE SHIELD OF OKLAHOMA 202	MED #2,500 DED EMP/SPOUSE	479.95
			MED #2,500 DED EMP/SPOUSE	479.95
		OKLAHOMA MUNICIPAL RETIRE	OMRF	167.55
			OMRF	175.24
		TRANSFER ACCOUNT	FICA	92.31
			MEDICARE	21.59

DEPARTMENT	FUND	VENDOR NAME	DESCRIPTION	AMOUNT
		UNIFIRST HOLDINGS, L.P.	DEC25-JAN26 CLEANING/UNIF	15.07
			DEC25-JAN26 CLEANING/UNIF	15.07
		OPTIONS COUNSELING SERVICE, INC.	EMPLOYEE ASSISTANCE PROGRA	1.50
			EMPLOYEE ASSISTANCE PROGRA	<u>1.50</u>
			TOTAL:	1,449.73
WATER PLANT	CHICKASHA MUNICIPA	USW UTILITY GROUP	WT PLANT OPS APR26	114,570.64
		CKENERGY ELECTRIC COOPERATIV	CK GR1 - GAS - DEC TO JUN	7,497.01
		EVIE JO ERWIN 2012 REVOCABLE	APR 2026 WTP LEASE PYMNT	2,500.00
		SUMMIT UTILITIES	COMBINED ACC 220100002901	<u>218.20</u>
			TOTAL:	124,785.85
WASTEWATER PLANT	CHICKASHA MUNICIPA	USW UTILITY GROUP	WWT PLANT OPS APR26	68,604.97
		PUBLIC SERVICE COMPANY OF OKLAHOMA	CITY ELECT SERV. JAN-JUN	42.42
		SUMMIT UTILITIES	COMBINED ACCT 22010002900	<u>54.88</u>
			TOTAL:	68,702.27
LINE MAINTENANCE DEPT	CHICKASHA MUNICIPA	CHICKASHA INDUSTRIAL & WE	WELDING SUPPLIES	14.24
			SMALL HAND TOOLS	145.95
			SAFTEY EQUIPMENT	281.42
		MARSHALL AUTO PARTS	REPAIR PARTS	21.63
			REPAIR PARTS	2.10
			REPAIR PARTS	49.46
			REPAIR PARTS	2.10-
			REPAIR PARTS	14.96-
			REPAIR PARTS	986.39
			REPAIR PARTS	8.39
			REPAIR PARTS	0.60
			REPAIR PARTS	56.96
			REPAIR PARTS	119.32
			REPAIR PARTS	115.96
		BLUE CROSS BLUE SHIELD OF OKLAHOMA 202	MED \$1,000 DED EMP ONLY	400.64
			MED \$1,000 DED EMP ONLY	400.64
			MED \$1,000 DED EMP/FAM	828.24
			MED \$1,000 DED EMP/FAM	828.24
			MED \$2,500 DED EMP/CHILD	358.68
			MED \$2,500 DED EMP/CHILD	358.68
			MED \$2,500 DED EMP/FAMILY	1,320.22
			MED \$2,500 DED EMP/FAMILY	1,320.22
		OKLAHOMA MUNICIPAL RETIRE	OMRF	1,307.83
			OMRF	1,268.93
		TRANSFER ACCOUNT	FICA	675.95
			MEDICARE	158.09
		FRONTIER EQUIPMENT	INNER 8" TUBE ASSEMBLY	3,449.47
		MCI WORLDCOM	PD LONG DISTANCE APR 26	91.65
			PD LONG DISTANCE MAR 26	91.65
		PRECISION FLUID POWER	CYLINDER REPAIR UNIT 2045	1,588.00
		UNIFIRST HOLDINGS, L.P.	LINE MAINT TEMPS	53.49
			DEC25-JAN26 CLEANING/UNIF	338.11
			LINE MAINT TEMPS	53.49
			DEC25-JAN26 CLEANING/UNIF	307.95
		OPTIONS COUNSELING SERVICE, INC.	EMPLOYEE ASSISTANCE PROGRA	10.50
			EMPLOYEE ASSISTANCE PROGRA	<u>10.50</u>
			TOTAL:	17,006.53
LAKE CHICKASHA	CHICKASHA MUNICIPA	AT&T MOBILITY	LAKE CHICK CELL JAN-JUN26	41.65

DEPARTMENT	FUND	VENDOR NAME	DESCRIPTION	AMOUNT
		CKENERGY ELECTRIC COOPERATIV	CK GR2 - GAS - DEC TO JUN	1,098.58
		TRANSFER ACCOUNT	FICA	8.52
			MEDICARE	1.99
			TOTAL:	1,150.74
BUILDING MAINTENANCE	CHICKASHA MUNICIPA	TDS TELECOM	4054537915 03/19-04/18	49.30
		BLUE CROSS BLUE SHIELD OF OKLAHOMA 202	MED \$1,000 DED EMP ONLY	200.32
			MED \$1,000 DED EMP ONLY	200.32
		DEHART AIR CONDITIONING AND ELECTRONIC	MAR26 PLANNED MAINT.	4,979.17
		COMMERCIAL CLEANING-SOLUTIONS, LLC	PW - CLEANING SERVICES	1,735.00
		OKLAHOMA MUNICIPAL RETIRE	OMRF	185.70
			OMRF	186.74
		SUMMIT UTILITIES	COMBINED ACCT 22010002900	2,226.01
			COMBINED ACC 22010002901	118.92
		TRANSFER ACCOUNT	FICA	102.40
			MEDICARE	23.95
		UNIFIRST HOLDINGS, L.P.	SUPPLIES AND UNIFORMS	13.54
			SUPPLIES AND UNIFORMS	8.52
		OPTIONS COUNSELING SERVICE, INC.	EMPLOYEE ASSISTANCE PROGRA	1.50
			EMPLOYEE ASSISTANCE PROGRA	1.50
		AT&T	03/15 - 04/14 26 WW TREAT	50.87
			TOTAL:	10,083.76
AIRPORT	AIRPORT	DBT TRANSPORTATION SERVICES, LLC	AWOS REPLACEMENT	7,829.28
		COMMERCIAL CLEANING-SOLUTIONS, LLC	AIRPORT - CLEANING SERVIC	850.00
		OKLAHOMA MUNICIPAL RETIRE	OMRF	197.63
			OMRF	200.64
		SUMMIT UTILITIES	COMBINED ACC 22010002901	221.19
		SMITH ROBERTS BALDISCHWIL	SURVEY	1,330.00
		TRANSFER ACCOUNT	FICA	187.65
			MEDICARE	43.88
		UNIFIRST HOLDINGS, L.P.	SUPPLIES AND UNIFORMS	39.19
			SUPPLIES AND UNIFORMS	35.17
		OPTIONS COUNSELING SERVICE, INC.	EMPLOYEE ASSISTANCE PROGRA	1.50
			EMPLOYEE ASSISTANCE PROGRA	1.50
			TOTAL:	10,937.63
NON-DEPARTMENTAL	AP/PAYROLL CASH FU	COLONIAL LIFE & ACCIDENT INSURANCE COM	COLONIAL ACCIDENT	121.53
			COLONIAL ACCIDENT	121.53
			COLONIAL ACCIDENT	121.53
			COLONIAL ACCIDENT	121.53
			COLONIAL GROUP ACCIDENT	391.46
			COLONIAL GROUP ACCIDENT	391.46
			COLONIAL GROUP ACCIDENT	391.46
			COLONIAL GROUP ACCIDENT	391.46
			COLONIAL CRITICAL ILLNESS	267.67
			COLONIAL CRITICAL ILLNESS	267.67
			COLONIAL CRITICAL ILLNESS	267.67
			COLONIAL CRITICAL ILLNESS	267.67
			COLONIAL DISABILITY	491.87
			COLONIAL DISABILITY	491.87
			COLONIAL DISABILITY	491.87
			COLONIAL DISABILITY	491.87
		CITY OF CHICKASHA	UNION ASSESSMENT FEE	9.86
			UNION ASSESSMENT FEE	9.86
			GARNISHMENT FEE	25.00

DEPARTMENT	FUND	VENDOR NAME	DESCRIPTION	AMOUNT
			GARNISHMENT FEE	25.00
		WASHINGTON NATIONAL INS. CO	GROUP #20057	1,002.88
			GROUP #20057	1,002.84
		BLUE CROSS BLUE SHIELD OF OKLAHOMA 202	MED \$1,000 DED EMP/CHILD	466.17
			MED \$1,000 DED EMP/CHILD	466.17
			MED \$1,000 DED EMP ONLY	1,427.75
			MED \$1,000 DED EMP ONLY	1,529.45
			MED \$1,000 DED EMP/FAM	1,393.88
			MED \$1,000 DED EMP/FAM	1,393.88
			MED \$1,000 DED EMP/SPOUSE	831.68
			MED \$1,000 DED EMP/SPOUSE	831.68
			MED \$2,500 DED EMP/CHILD	538.02
			MED \$2,500 DED EMP/CHILD	538.02
			MED \$2,500 DED EMP ONLY	743.25
			MED \$2,500 DED EMP ONLY	743.25
			MED \$2,500 DED EMP/FAMILY	1,815.33
			MED \$2,500 DED EMP/FAMILY	1,815.33
			MED #2,500 DED EMP/SPOUSE	479.92
			MED #2,500 DED EMP/SPOUSE	479.92
		THE STANDARD INSURANCE COMPANY	VOLUNTARY LIFE	566.10
			VOLUNTARY LIFE	542.21
		COURTESY LOANS		70.27-
				70.27
		ROBINSON HOOVER & FUDGE PLLC		334.11
		DEPARTMENT OF HUMAN SERVICES		80.69
				151.99
				92.30
				180.00
				140.07
				9.87
				77.51
		OKLAHOMA FIREFIGHTERS	FIRE PENSION BUY BACK	174.01
			FIRE PENSION	11,502.47
		CITY OF CHICKASHA-(ACH) OKLAHOMA POLIC	POLICE PENSION	5,993.71
		OKLAHOMA MUNICIPAL RETIRE	OMRF3	492.31
			OMRF	5,639.26
			OMRF	5,571.60
		FIREFIGHTERS SEC LOCAL 20	FIRE INSURANCE FEE	185.00
			FIRE INSURANCE FEE	185.00
			FIRE UNION DUES	1,330.00
			FIRE UNION DUES	1,330.00
		FIREMENS SPECIAL FUND	FIRE SPECIAL FUND	525.00
			FIRE SPECIAL FUND	525.00
		FRATERNAL ORDER OF POLICE	POLICE UNION	540.00
			POLICE UNION	540.00
		TRANSFER ACCOUNT	ENTITY 0037102001	8,731.77
			FEDERAL WITHHOLDING	27,388.10
			STATE INCOME TAX	11,000.00
			FICA	13,081.73
			MEDICARE	5,110.35
		IAFF LOCAL 2041 (HEALTH INS)	FIRE CANCER	346.45
			FIRE CANCER	346.45
			FIR/EECH OPTION A	781.20
			FIR/EECH OPTION A	651.00
			FIR/EEC OPTION D	81.70
			FIR/EEC OPTION D	81.70

DEPARTMENT	FUND	VENDOR NAME	DESCRIPTION	AMOUNT
			FIRE DISABILITY AFTER TAX	440.41
			FIRE DISABILITY AFTER TAX	440.41
			FIRE EE/CHILD(REN) DENTAL	41.60
			FIRE EE/CHILD(REN) DENTAL	36.40
			FIRE EE DENTAL	32.00
			FIRE EE DENTAL	32.00
			FIRE FAMILY DENTAL	107.90
			FIRE FAMILY DENTAL	116.20
			FIRE EE/SPOUSE DENTAL	52.20
			FIRE EE/SPOUSE DENTAL	52.20
			FIR/EE OPTION A	225.60
			FIR/EE OPTION A	225.60
			FIR/EE OPTION B	69.30
			FIR/EE OPTION B	69.30
			FIRE/EEC OPTION C	125.60
			FIRE/EEC OPTION C	125.60
			FIR/FAM OPTION A	2,576.60
			FIR/FAM OPTION A	2,774.80
			FIR/FAM OPTION B	179.00
			FIR/FAM OPTION B	179.00
			FIR/FAM OPTION D	292.60
			FIR/FAM OPTION D	292.60
			FIRE HARTFORD	381.05
			FIRE HARTFORD	381.05
			FIRE/EE OPTION D	55.90
			FIRE/EE OPTION D	55.90
			FIR/EESP OPTION A	1,169.60
			FIR/EESP OPTION A	1,169.60
			FIRE/EES OPTION C	110.20
			FIRE/EES OPTION C	110.20
			FIR/EE/CH VISION	19.60
			FIR/EE/CH VISION	19.60
			FIR/EE VISION	10.80
			FIR/EE VISION	10.80
			FIR/FAM VISION	57.20
			FIR/FAM VISION	57.20
			FIRE VOLUNTARY LIFE-AFTER	663.33
			FIRE VOLUNTARY LIFE-AFTER	663.33
			FIR/EESP VISION	30.00
			FIR/EESP VISION	30.00
		CITY OF CHICKASHA FLEX SPENDING ACCOUN	UNREIMBURSED MEDICAL 23-19	2,030.01
		IAFF - FIREPAC	IAFF FIREPAC	145.67
			IAFF FIREPAC	<u>145.67</u>
			TOTAL:	<u>142,771.55</u>

DEPARTMENT	FUND	VENDOR NAME	DESCRIPTION	AMOUNT
------------	------	-------------	-------------	--------

```

===== FUND TOTALS =====
11  GENERAL FUND                441,020.71
23  EMERGENCY MED SERV FUND     20,947.54
31  CHICKASHA MUNICIPAL AUTH    249,179.67
39  AIRPORT                     10,937.63
99  AP/PAYROLL CASH FUND        142,771.55
-----
                GRAND TOTAL:    864,857.10
-----

```

TOTAL PAGES: 13

SELECTION CRITERIA

SELECTION OPTIONS

VENDOR SET: 99-AP VENDOR LIST
VENDOR: All
CLASSIFICATION: All
BANK CODE: All
ITEM DATE: 0/00/0000 THRU 99/99/9999
ITEM AMOUNT: 99,999,999.00CR THRU 99,999,999.00
GL POST DATE: 0/00/0000 THRU 99/99/9999
CHECK DATE: 3/25/2026 THRU 4/07/2026

PAYROLL SELECTION

PAYROLL EXPENSES: NO
EXPENSE TYPE: N/A
CHECK DATE: 0/00/0000 THRU 99/99/9999

PRINT OPTIONS

PRINT DATE: None
SEQUENCE: By Department
DESCRIPTION: Distribution
GL ACCTS: NO
REPORT TITLE: COUNCIL REPORT FOR 04.07.2026
SIGNATURE LINES: 0

PACKET OPTIONS

INCLUDE REFUNDS: YES
INCLUDE OPEN ITEM:NO

CHICKASHA

Meeting Type: Council Agenda 4-6-2026

Meeting Date: 4/6/2026

Department: Finance

Agenda Item No. 4.c.

AGENDA ITEM: Acknowledge receipt of the Financials for February 2026.

I. BACKGROUND/DESCRIPTION:

II. RECOMMENDED ACTION:

Acknowledge receipt of the Financials for February 2026.

III. FISCAL INFORMATION -

IV. FUND INFORMATION:

Dept. Director: Rich Edwards, Finance Director	Fund	Account	Amount
	(To)		
	FUND	ACCOUNT	AMOUNT
Meeting Date: April 6, 2026	(From)		

V. ATTACHMENTS:

- 20260331161035271

CITY OF CHICKASHA
 FINANCIAL STATEMENT (UNAUDITED)
 AS OF: FEBRUARY 28TH, 2026

11 -GENERAL FUND
 FINANCIAL SUMMARY

% OF YEAR COMPLETED: 66.67

	CURRENT BUDGET	CURRENT PERIOD	PRIOR YEAR EXPENSE	Y-T-D ACTUAL	Y-T-D ENCUMBRANCE	BUDGET BALANCE	% OF BUDGET
REVENUE SUMMARY							
PERMITS	289,500.00	35,327.12	0.00	258,560.90	0.00	30,939.10	89.31
LICENSES	130,000.00	6,884.00	0.00	62,010.50	0.00	67,989.50	47.70
CEMETERY	58,000.00	4,781.25	0.00	58,131.50	0.00 (131.50)	100.23
FEES	72,800.00	17,508.87	0.00	196,884.91	0.00 (124,084.91)	270.45
RENT	2,800.00	330.00	0.00	2,096.00	0.00	704.00	74.86
STATE TAX	19,892,550.00	1,724,746.84	0.00	12,424,363.13	0.00	7,468,186.87	62.46
OTHER TAX	865,000.00	64,900.26	0.00	558,012.52	0.00	306,987.48	64.51
FRANCHISE TAX	587,575.00	117,835.88	0.00	521,566.28	0.00	66,008.72	88.77
GRANTS AND PROGRAMS	80,310.00	16,200.00	0.00	42,410.00	0.00	37,900.00	52.81
CONTRACTS/AGREEMENTS	0.00	0.00	0.00	229,864.00	0.00 (229,864.00)	0.00
SWIMMING POOL/SPORTS COM	40,500.00	270.00	0.00	40,505.98	0.00 (5.98)	100.01
MISC REVENUES	25,000.00	9,308.29	0.00	56,915.35	0.00 (31,915.35)	227.66
TRANSFER OTHER FUNDS-EQU	5,082,425.00	1,272,951.34	0.00	3,430,467.90	0.00	1,651,957.10	67.50
INTEREST	0.00	1,075.99	0.00	20,102.87	0.00 (20,102.87)	0.00
PRIOR YEAR FUND BALANCE C	1,238,764.12	-0.00	0.00	0.00	0.00	1,238,764.12	0.00
*** TOTAL REVENUES ***	28,365,224.12	3,272,119.84	0.00	17,901,891.84	0.00	10,463,332.28	63.11

EXPENDITURE SUMMARY

01-ADMINISTRATION	642,881.00	52,734.76	0.00	379,177.10	35,435.45	228,268.45	64.49
04-EMERGENCY MANAGEMENT	196,172.00	15,730.76	0.00	90,630.40	47,346.13	58,195.47	70.33
02-FIRE DEPARTMENT-PS	544,320.00	38,719.52	0.00	374,652.41	66,110.03	103,557.56	80.97
21-FIRE OPERATIONS	3,787,915.00	254,278.39	0.00	1,937,937.75	192,321.67	1,657,655.58	56.24
03-POLICE DEPARTMENT-PS	895,923.00	45,440.39	0.00	479,237.55	70,747.89	345,937.56	61.39
41-PATROL SERVICES	2,539,846.00	324,883.06	0.00	1,941,266.18	119,182.05	479,397.77	81.12
42-INVESITGATIONS	295,397.00	31,327.67	0.00	245,564.36	19,834.36	29,998.28	89.04
43-ANIMAL CONTROL	373,547.00	72,625.52	0.00	260,280.94	81,802.13	31,463.93	91.58
44-MUNICIPAL COURT	94,888.00	6,061.88	0.00	51,639.68	87.00	43,161.32	54.51
45-DISPATCH	462,834.00	37,995.15	0.00	308,158.23	8,954.06	145,721.71	68.52
51-PARK MAINTENANCE	953,243.00	56,951.39	0.00	787,839.79	79,398.60	86,004.61	90.98
52-SPORTS COMPLEX	450,689.00	13,062.53	0.00	231,753.10	96,213.27	122,722.63	72.77
54-SHANNON SPRINGS (FOL)	180,500.00	727.45	0.00	183,057.40	7,728.56 (10,285.96)	105.70
06-CEMETERY MAINTENANC-C	503,802.00	32,544.38	0.00	319,238.16	22,176.94	242,386.90	58.48
08-LIBRARY - C&R	557,282.00	43,614.11	0.00	359,063.83	62,284.52	135,933.65	75.61
09-STREET & STORM	1,510,829.00	82,108.11	0.00	719,861.81	213,663.80	577,303.39	61.79
10-FLEET	179,483.00	11,561.80	0.00	122,678.15	10,679.60	46,125.25	74.30
14-FINANCE-GG	683,720.00	38,097.57	0.00	361,570.73	149,895.02	172,254.25	74.01
07-HUMAN RESOURCES	271,301.00	25,259.93	0.00	169,465.45	18,744.79	83,090.76	69.37
16-COMM DEVEL/PLAN SERV	330,094.00	18,955.34	0.00	180,641.11	15,063.93	134,388.96	59.29
18-BUILDING SERVICES	249,461.00	58,926.39	0.00	367,837.81	123,340.53 (241,717.34)	196.90
46-CODE COMPLIANCE	274,851.00	10,762.58	0.00	121,429.52	12,892.25	140,529.23	48.87
17-GENERAL GOVERNMENT-GG	12,247,291.12	957,286.11	0.00	8,006,508.74	166,989.83	4,073,792.55	66.74
70-GRANT(S)	58,955.00	1,404.65	0.00	36,993.92	5,818.20	16,142.88	72.62
*** TOTAL EXPENDITURES ***	28,365,224.12	2,231,059.44	0.00	18,036,484.12	1,626,710.61	8,702,029.39	69.32
** REVENUE OVER(UNDER) EXPENDITURES **	0.00	1,041,060.40	0.00 (134,592.28)	(1,626,710.61)	1,761,302.89	0.00

CITY OF CHICKASHA
 FINANCIAL STATEMENT (UNAUDITED)
 AS OF: FEBRUARY 28TH, 2026

20 -DONATIONS FUND
 FINANCIAL SUMMARY

% OF YEAR COMPLETED: 66.67

	CURRENT BUDGET	CURRENT PERIOD	PRIOR YEAR EXPENSE	Y-T-D ACTUAL	Y-T-D ENCUMBRANCE	BUDGET BALANCE	% OF BUDGET
<u>REVENUE SUMMARY</u>							
DONATIONS	22,348.80	12,015.00	0.00	44,236.47	0.00	(21,887.67)	197.94
INTEREST	<u>0.00</u>	<u>697.95</u>	<u>0.00</u>	<u>6,038.39</u>	<u>0.00</u>	(<u>6,038.39</u>)	<u>0.00</u>
*** TOTAL REVENUES ***	22,348.80	12,712.95	0.00	50,274.86	0.00	(27,926.06)	224.96
<u>EXPENDITURE SUMMARY</u>							
20-DONATIONS-GG	<u>22,348.80</u>	<u>11,053.94</u>	<u>0.00</u>	<u>35,849.20</u>	<u>0.00</u>	(<u>13,500.40</u>)	<u>160.41</u>
*** TOTAL EXPENDITURES ***	22,348.80	11,053.94	0.00	35,849.20	0.00	(13,500.40)	160.41
** REVENUE OVER (UNDER) EXPENDITURES **	0.00	1,659.01	0.00	14,425.66	0.00	(14,425.66)	0.00

CITY OF CHICKASHA
 FINANCIAL STATEMENT (UNAUDITED)
 AS OF: FEBRUARY 28TH, 2026

22 -TAX INCREMENT DISTRIC
 FINANCIAL SUMMARY

% OF YEAR COMPLETED: 66.67

	CURRENT BUDGET	CURRENT PERIOD	PRIOR YEAR EXPENSE	Y-T-D ACTUAL	Y-T-D ENCUMBRANCE	BUDGET BALANCE	% OF BUDGET
<u>REVENUE SUMMARY</u>							
INTEREST	95.00	0.00	0.00	81.73	0.00	13.27	86.03
PRIOR YEAR FUND BALANCE C	<u>120,261.00</u>	<u>0.00</u>	<u>0.00</u>	<u>0.00</u>	<u>0.00</u>	<u>120,261.00</u>	<u>0.00</u>
*** TOTAL REVENUES ***	<u>120,356.00</u>	<u>0.00</u>	<u>0.00</u>	<u>81.73</u>	<u>0.00</u>	<u>120,274.27</u>	<u>0.07</u>
<u>EXPENDITURE SUMMARY</u>							
22-TAX INCREMENT DISTRIC	<u>120,356.00</u>	<u>0.00</u>	<u>0.00</u>	<u>120,341.35</u>	<u>0.00</u>	<u>14.65</u>	<u>99.99</u>
*** TOTAL EXPENDITURES ***	<u>120,356.00</u>	<u>0.00</u>	<u>0.00</u>	<u>120,341.35</u>	<u>0.00</u>	<u>14.65</u>	<u>99.99</u>
** REVENUE OVER (UNDER) EXPENDITURES **	<u>0.00</u>	<u>0.00</u>	<u>0.00</u>	<u>(120,259.62)</u>	<u>0.00</u>	<u>120,259.62</u>	<u>0.00</u>

CITY OF CHICKASHA
 FINANCIAL STATEMENT (UNAUDITED)
 AS OF: FEBRUARY 28TH, 2026

23 -EMERGENCY MED SERV FUND
 FINANCIAL SUMMARY

% OF YEAR COMPLETED: 66.67

	CURRENT BUDGET	CURRENT PERIOD	PRIOR YEAR EXPENSE	Y-T-D ACTUAL	Y-T-D ENCUMBRANCE	BUDGET BALANCE	% OF BUDGET
<u>REVENUE SUMMARY</u>							
EMS FEES	1,910,000.00	107,670.67	0.00	972,932.86	0.00	937,067.14	50.94
GRANTS AND PROGRAMS	646,000.00	383,260.00	0.00	515,243.22	0.00	130,756.78	79.76
MISC REVENUES	0.00	0.00	0.00	228.98	0.00	(228.98)	0.00
INTEREST	11,845.00	954.27	0.00	14,953.96	0.00	(3,108.96)	126.25
PRIOR YEAR FUND BALANCE C	<u>146,681.00</u>	<u>0.00</u>	<u>0.00</u>	<u>0.00</u>	<u>0.00</u>	<u>146,681.00</u>	<u>0.00</u>
*** TOTAL REVENUES ***	<u>2,714,526.00</u>	<u>491,884.94</u>	<u>0.00</u>	<u>1,503,359.02</u>	<u>0.00</u>	<u>1,211,166.98</u>	<u>55.38</u>
<u>EXPENDITURE SUMMARY</u>							
02-FIRE DEPARTMENT-PS	<u>2,714,526.00</u>	<u>168,377.69</u>	<u>0.00</u>	<u>2,297,065.71</u>	<u>253,078.30</u>	<u>164,381.99</u>	<u>93.94</u>
*** TOTAL EXPENDITURES ***	<u>2,714,526.00</u>	<u>168,377.69</u>	<u>0.00</u>	<u>2,297,065.71</u>	<u>253,078.30</u>	<u>164,381.99</u>	<u>93.94</u>
** REVENUE OVER (UNDER) EXPENDITURES **	<u>0.00</u>	<u>323,507.25</u>	<u>0.00</u>	<u>(793,706.69)</u>	<u>(253,078.30)</u>	<u>1,046,784.99</u>	<u>0.00</u>

CITY OF CHICKASHA
 FINANCIAL STATEMENT (UNAUDITED)
 AS OF: FEBRUARY 28TH, 2026

25 -CHICKASHA INDUST AUTH
 FINANCIAL SUMMARY

% OF YEAR COMPLETED: 66.67

	CURRENT BUDGET	CURRENT PERIOD	PRIOR YEAR EXPENSE	Y-T-D ACTUAL	Y-T-D ENCUMBRANCE	BUDGET BALANCE	% OF BUDGET
<u>REVENUE SUMMARY</u>							
GRANTS AND PROGRAMS	30,000.00	0.00	0.00	0.00	0.00	30,000.00	0.00
MISC REVENUES	0.00	0.00	0.00	2,500.00	0.00	(2,500.00)	0.00
TRANSFER OTHER FUNDS-EQU	612,000.00	44,527.44	0.00	382,264.50	0.00	229,735.50	62.46
INTEREST	0.00	160.83	0.00	1,247.48	0.00	(1,247.48)	0.00
PRIOR YEAR FUND BALANCE C	<u>368,097.00</u>	<u>0.00</u>	<u>0.00</u>	<u>0.00</u>	<u>0.00</u>	<u>368,097.00</u>	<u>0.00</u>
*** TOTAL REVENUES ***	<u>1,010,097.00</u>	<u>44,688.27</u>	<u>0.00</u>	<u>386,011.98</u>	<u>0.00</u>	<u>624,085.02</u>	<u>38.22</u>
<u>EXPENDITURE SUMMARY</u>							
25-CHICKASHA INDUSTRIAL	<u>1,010,097.00</u>	<u>40,820.01</u>	<u>0.00</u>	<u>423,305.53</u>	<u>380,179.37</u>	<u>206,612.10</u>	<u>79.55</u>
*** TOTAL EXPENDITURES ***	<u>1,010,097.00</u>	<u>40,820.01</u>	<u>0.00</u>	<u>423,305.53</u>	<u>380,179.37</u>	<u>206,612.10</u>	<u>79.55</u>
** REVENUE OVER (UNDER) EXPENDITURES **	<u>0.00</u>	<u>3,868.26</u>	<u>0.00</u>	<u>(37,293.55)</u>	<u>(380,179.37)</u>	<u>417,472.92</u>	<u>0.00</u>

CITY OF CHICKASHA
 FINANCIAL STATEMENT (UNAUDITED)
 AS OF: FEBRUARY 28TH, 2026

26 -ED-DEDICATED SALES TAX
 FINANCIAL SUMMARY

% OF YEAR COMPLETED: 66.67

	CURRENT BUDGET	CURRENT PERIOD	PRIOR YEAR EXPENSE	Y-T-D ACTUAL	Y-T-D ENCUMBRANCE	BUDGET BALANCE	% OF BUDGET
<u>REVENUE SUMMARY</u>							
INTEREST	15,000.00	14.32	0.00	151.08	0.00	14,848.92	1.01
PRIOR YEAR FUND BALANCE C	<u>900,000.00</u>	<u>0.00</u>	<u>0.00</u>	<u>0.00</u>	<u>0.00</u>	<u>900,000.00</u>	<u>0.00</u>
*** TOTAL REVENUES ***	<u>915,000.00</u>	<u>14.32</u>	<u>0.00</u>	<u>151.08</u>	<u>0.00</u>	<u>914,848.92</u>	<u>0.02</u>
<u>EXPENDITURE SUMMARY</u>							
26-ED DED. SALES TAX	<u>915,000.00</u>	<u>0.00</u>	<u>0.00</u>	<u>0.00</u>	<u>0.00</u>	<u>915,000.00</u>	<u>0.00</u>
*** TOTAL EXPENDITURES ***	<u>915,000.00</u>	<u>0.00</u>	<u>0.00</u>	<u>0.00</u>	<u>0.00</u>	<u>915,000.00</u>	<u>0.00</u>
** REVENUE OVER (UNDER) EXPENDITURES **	<u>0.00</u>	<u>14.32</u>	<u>0.00</u>	<u>151.08</u>	<u>0.00</u>	<u>(151.08)</u>	<u>0.00</u>

CITY OF CHICKASHA
 FINANCIAL STATEMENT (UNAUDITED)
 AS OF: FEBRUARY 28TH, 2026

27 -E-911 FUND
 FINANCIAL SUMMARY

% OF YEAR COMPLETED: 66.67

	CURRENT BUDGET	CURRENT PERIOD	PRIOR YEAR EXPENSE	Y-T-D ACTUAL	Y-T-D ENCUMBRANCE	BUDGET BALANCE	% OF BUDGET
<u>REVENUE SUMMARY</u>							
E-911	200,000.00	19,739.63	0.00	157,670.96	0.00	42,329.04	78.84
GRANTS AND PROGRAMS	23,940.00	0.00	0.00	36,640.00	0.00	12,700.00	153.05
INTEREST	<u>10,000.00</u>	<u>954.30</u>	<u>0.00</u>	<u>9,445.00</u>	<u>0.00</u>	<u>555.00</u>	<u>94.45</u>
*** TOTAL REVENUES ***	<u>233,940.00</u>	<u>20,693.93</u>	<u>0.00</u>	<u>203,755.96</u>	<u>0.00</u>	<u>30,184.04</u>	<u>87.10</u>
<u>EXPENDITURE SUMMARY</u>							
27-EMERGENCY 911-PS	<u>233,940.00</u>	<u>2,064.57</u>	<u>0.00</u>	<u>51,968.44</u>	<u>8,565.42</u>	<u>173,406.14</u>	<u>25.88</u>
*** TOTAL EXPENDITURES ***	<u>233,940.00</u>	<u>2,064.57</u>	<u>0.00</u>	<u>51,968.44</u>	<u>8,565.42</u>	<u>173,406.14</u>	<u>25.88</u>
** REVENUE OVER (UNDER) EXPENDITURES **	<u>0.00</u>	<u>18,629.36</u>	<u>0.00</u>	<u>151,787.52</u>	<u>(8,565.42)</u>	<u>143,222.10</u>	<u>0.00</u>

CITY OF CHICKASHA
 FINANCIAL STATEMENT (UNAUDITED)
 AS OF: FEBRUARY 28TH, 2026

28 -FIRE/EMS TRAINING FUND
 FINANCIAL SUMMARY

% OF YEAR COMPLETED: 66.67

	CURRENT BUDGET	CURRENT PERIOD	PRIOR YEAR EXPENSE	Y-T-D ACTUAL	Y-T-D ENCUMBRANCE	BUDGET BALANCE	% OF BUDGET
<u>REVENUE SUMMARY</u>							
TRANSFER OTHER FUNDS-EQU	100.00	0.03	0.00	20.26	0.00	79.74	20.26
INTEREST	0.00	1.77	0.00	18.58	0.00	(18.58)	0.00
*** TOTAL REVENUES ***	100.00	1.80	0.00	38.84	0.00	61.16	38.84
<u>EXPENDITURE SUMMARY</u>							
02-FIRE DEPARTMENT-PS	100.00	0.00	0.00	0.00	0.00	100.00	0.00
*** TOTAL EXPENDITURES ***	100.00	0.00	0.00	0.00	0.00	100.00	0.00
** REVENUE OVER (UNDER) EXPENDITURES **	0.00	1.80	0.00	38.84	0.00	(38.84)	0.00

CITY OF CHICKASHA
 FINANCIAL STATEMENT (UNAUDITED)
 AS OF: FEBRUARY 28TH, 2026

29 -POLICE TRAINING FUND
 FINANCIAL SUMMARY

% OF YEAR COMPLETED: 66.67

	CURRENT BUDGET	CURRENT PERIOD	PRIOR YEAR EXPENSE	Y-T-D ACTUAL	Y-T-D ENCUMBRANCE	BUDGET BALANCE	% OF BUDGET
<u>REVENUE SUMMARY</u>							
MISC REVENUES	875.00	0.00	0.00	875.00	0.00	0.00	100.00
TRANSFER OTHER FUNDS-EQU	4,000.00	0.00	0.00	3,660.79	0.00	339.21	91.52
INTEREST	500.00	70.84	0.00	738.19	0.00	(238.19)	147.64
*** TOTAL REVENUES ***	5,375.00	70.84	0.00	5,273.98	0.00	101.02	98.12
<u>EXPENDITURE SUMMARY</u>							
03-POLICE DEPARTMENT-PS	5,375.00	0.00	0.00	0.00	0.00	5,375.00	0.00
*** TOTAL EXPENDITURES ***	5,375.00	0.00	0.00	0.00	0.00	5,375.00	0.00
** REVENUE OVER (UNDER) EXPENDITURES **	0.00	70.84	0.00	5,273.98	0.00	(5,273.98)	0.00

FINANCIAL STATEMENT (UNAUDITED)

AS OF: FEBRUARY 28TH, 2026

31 -CHICKASHA MUNICIPAL AUTH

FINANCIAL SUMMARY

% OF YEAR COMPLETED: 66.67

	CURRENT BUDGET	CURRENT PERIOD	PRIOR YEAR EXPENSE	Y-T-D ACTUAL	Y-T-D ENCUMBRANCE	BUDGET BALANCE	% OF BUDGET
<u>REVENUE SUMMARY</u>							
LICENSES	15,000.00	40.00	0.00	7,800.00	0.00	7,200.00	52.00
FEES	24,500.00	1,990.67	0.00	14,952.77	0.00	9,547.23	61.03
RENT	151,862.00	3,853.40	0.00	132,370.90	0.00	19,491.10	87.17
OIL & GAS	12,660.00	0.00	0.00	10,250.00	0.00	2,410.00	80.96
UTILITY SERVICE	10,559,250.00	867,555.03	0.00	6,545,523.12	0.00	4,013,726.88	61.99
MISC REVENUES	50,000.00	5,543.24	0.00	20,412.85	0.00	29,587.15	40.83
TRANSFER OTHER FUNDS-EQU	7,682,467.00	338,638.66	0.00	4,542,029.52	0.00	3,140,437.48	59.12
INTEREST	500,000.00	36,138.08	0.00	1,640,781.22	0.00	(1,140,781.22)	328.16
PRIOR YEAR FUND BALANCE C	3,680,563.00	0.00	0.00	0.00	0.00	3,680,563.00	0.00
*** TOTAL REVENUES ***	22,676,302.00	1,253,759.08	0.00	12,914,120.38	0.00	9,762,181.62	56.95
<u>EXPENDITURE SUMMARY</u>							
30-CMA CAPITAL	1,085,703.00	14,894.04	0.00	360,564.15	416,824.67	308,314.18	71.60
31-CMA GENERAL-BT	5,309,865.00	1,280,087.04	0.00	3,605,978.95	76,234.89	1,627,651.16	69.35
15-UTILITY BILLING	340,102.00	18,732.62	0.00	181,044.12	25,179.52	133,878.36	60.64
32-PUBLIC WORKS ADMIN-BT	387,691.00	19,382.95	0.00	158,037.99	16,636.59	213,016.42	45.06
33-SANITATION-BT	2,778,394.00	225,641.43	0.00	1,621,900.13	1,156,846.91	(353.04)	100.01
34-WATER PLANT-BT	2,810,129.00	53,442.78	0.00	1,391,103.60	1,060,598.42	358,426.98	87.25
35-WASTEWATER PLANT-BT	1,167,256.00	15,313.52	0.00	603,294.63	482,726.77	81,234.60	93.04
36-LINE MAINTENANCE-BT	2,885,450.00	77,988.34	0.00	851,708.67	535,993.37	1,497,747.96	48.09
37-LAKE CHICKASHA-C&R	788,465.00	2,330.78	0.00	34,688.48	12,032.09	741,744.43	5.93
38-BUILDING MAINTENANCE	473,292.00	19,799.03	0.00	308,768.13	148,392.13	16,131.74	96.59
39-STORMWATER MANAGEMENT	504,500.00	0.00	0.00	260,708.38	268,351.62	(24,560.00)	104.87
44-WATER PLANT PROJECT	4,145,455.00	369,298.70	0.00	3,117,950.81	467,577.70	559,926.49	86.49
*** TOTAL EXPENDITURES ***	22,676,302.00	2,096,912.03	0.00	12,495,740.04	4,667,394.68	5,513,159.28	75.69
** REVENUE OVER(UNDER) EXPENDITURES **	0.00	(843,152.95)	0.00	418,372.34	(4,667,394.68)	4,249,022.34	0.00

CITY OF CHICKASHA
 FINANCIAL STATEMENT (UNAUDITED)
 AS OF: FEBRUARY 28TH, 2026

39 -AIRPORT
 FINANCIAL SUMMARY

% OF YEAR COMPLETED: 66.67

	CURRENT BUDGET	CURRENT PERIOD	PRIOR YEAR EXPENSE	Y-T-D ACTUAL	Y-T-D ENCUMBRANCE	BUDGET BALANCE	% OF BUDGET
<u>REVENUE SUMMARY</u>							
RENT	142,167.00	9,287.50	0.00	80,726.39	0.00	61,440.61	56.78
GRANTS AND PROGRAMS	0.00	0.00	0.00	1,049,000.00	0.00	(1,049,000.00)	0.00
DONATIONS	50,000.00	250.00	0.00	250.00	0.00	49,750.00	0.50
OIL & GAS	250,000.00	22,992.06	0.00	186,485.72	0.00	63,514.28	74.59
MISC REVENUES	500.00	0.00	0.00	(200.00)	0.00	700.00	40.00-
INTEREST	36,505.00	72.06	0.00	53,087.65	0.00	(16,582.65)	145.43
PRIOR YEAR FUND BALANCE C	<u>83,696.00</u>	<u>0.00</u>	<u>0.00</u>	<u>0.00</u>	<u>0.00</u>	<u>83,696.00</u>	<u>0.00</u>
*** TOTAL REVENUES ***	<u>562,868.00</u>	<u>32,601.62</u>	<u>0.00</u>	<u>1,369,349.76</u>	<u>0.00</u>	<u>(806,481.76)</u>	<u>243.28</u>
<u>EXPENDITURE SUMMARY</u>							
39-AIRPORT-BT	<u>562,868.00</u>	<u>13,805.27</u>	<u>0.00</u>	<u>289,658.58</u>	<u>145,817.01</u>	<u>127,392.41</u>	<u>77.37</u>
*** TOTAL EXPENDITURES ***	<u>562,868.00</u>	<u>13,805.27</u>	<u>0.00</u>	<u>289,658.58</u>	<u>145,817.01</u>	<u>127,392.41</u>	<u>77.37</u>
** REVENUE OVER(UNDER) EXPENDITURES **	<u>0.00</u>	<u>18,796.35</u>	<u>0.00</u>	<u>1,079,691.18</u>	<u>(145,817.01)</u>	<u>(933,874.17)</u>	<u>0.00</u>

CITY OF CHICKASHA
 FINANCIAL STATEMENT (UNAUDITED)
 AS OF: FEBRUARY 28TH, 2026

52 -CAPITAL PROJECTS FUND
 FINANCIAL SUMMARY

% OF YEAR COMPLETED: 66.67

	CURRENT BUDGET	CURRENT PERIOD	PRIOR YEAR EXPENSE	Y-T-D ACTUAL	Y-T-D ENCUMBRANCE	BUDGET BALANCE	% OF BUDGET
<u>REVENUE SUMMARY</u>							
OIL & GAS	200,000.00	125,089.38	0.00	353,490.66	0.00	(153,490.66)	176.75
INTEREST	17,000.00	3,069.71	0.00	26,763.93	0.00	(9,763.93)	157.43
PRIOR YEAR FUND BALANCE C	<u>1,655,512.00</u>	<u>0.00</u>	<u>0.00</u>	<u>0.00</u>	<u>0.00</u>	<u>1,655,512.00</u>	<u>0.00</u>
*** TOTAL REVENUES ***	<u>1,872,512.00</u>	<u>128,159.09</u>	<u>0.00</u>	<u>380,254.59</u>	<u>0.00</u>	<u>1,492,257.41</u>	<u>20.31</u>
<u>EXPENDITURE SUMMARY</u>							
CAPITAL PROJECTS	<u>1,872,512.00</u>	<u>0.00</u>	<u>0.00</u>	<u>710,505.00</u>	<u>356,342.50</u>	<u>805,664.50</u>	<u>56.97</u>
*** TOTAL EXPENDITURES ***	<u>1,872,512.00</u>	<u>0.00</u>	<u>0.00</u>	<u>710,505.00</u>	<u>356,342.50</u>	<u>805,664.50</u>	<u>56.97</u>
** REVENUE OVER (UNDER) EXPENDITURES **	<u>0.00</u>	<u>128,159.09</u>	<u>0.00</u>	<u>(330,250.41)</u>	<u>(356,342.50)</u>	<u>686,592.91</u>	<u>0.00</u>

CITY OF CHICKASHA
 FINANCIAL STATEMENT (UNAUDITED)
 AS OF: FEBRUARY 28TH, 2026

53 -CIP-DEDICATED SALES TAX
 FINANCIAL SUMMARY

% OF YEAR COMPLETED: 66.67

	CURRENT BUDGET	CURRENT PERIOD	PRIOR YEAR EXPENSE	Y-T-D ACTUAL	Y-T-D ENCUMBRANCE	BUDGET BALANCE	% OF BUDGET
<u>REVENUE SUMMARY</u>							
INTEREST	0.00	5,649.31	0.00	74,791.97	0.00	(74,791.97)	0.00
PRIOR YEAR FUND BALANCE C	<u>4,284,307.00</u>	<u>0.00</u>	<u>0.00</u>	<u>0.00</u>	<u>0.00</u>	<u>4,284,307.00</u>	<u>0.00</u>
*** TOTAL REVENUES ***	<u>4,284,307.00</u>	<u>5,649.31</u>	<u>0.00</u>	<u>74,791.97</u>	<u>0.00</u>	<u>4,209,515.03</u>	<u>1.75</u>
<u>EXPENDITURE SUMMARY</u>							
53-DEDICATED SALE TAX-GG	<u>4,284,307.00</u>	<u>0.00</u>	<u>0.00</u>	<u>1,473,006.30</u>	<u>66,248.64</u>	<u>2,745,052.06</u>	<u>35.93</u>
*** TOTAL EXPENDITURES ***	<u>4,284,307.00</u>	<u>0.00</u>	<u>0.00</u>	<u>1,473,006.30</u>	<u>66,248.64</u>	<u>2,745,052.06</u>	<u>35.93</u>
** REVENUE OVER(UNDER) EXPENDITURES **	<u>0.00</u>	<u>5,649.31</u>	<u>0.00</u>	<u>(1,398,214.33)</u>	<u>(66,248.64)</u>	<u>1,464,462.97</u>	<u>0.00</u>

CITY OF CHICKASHA
 FINANCIAL STATEMENT (UNAUDITED)
 AS OF: FEBRUARY 28TH, 2026

54 -STREET AND ALLEY FUND
 FINANCIAL SUMMARY

% OF YEAR COMPLETED: 66.67

	CURRENT BUDGET	CURRENT PERIOD	PRIOR YEAR EXPENSE	Y-T-D ACTUAL	Y-T-D ENCUMBRANCE	BUDGET BALANCE	% OF BUDGET
<u>REVENUE SUMMARY</u>							
STATE TAX	30,000.00	0.00	0.00	29,448.99	0.00	551.01	98.16
OTHER TAX	115,000.00	10,786.09	0.00	76,780.41	0.00	38,219.59	66.77
INTEREST	2,050.00	424.74	0.00	3,991.65	0.00	(1,941.65)	194.71
PRIOR YEAR FUND BALANCE C	<u>56,850.00</u>	<u>0.00</u>	<u>0.00</u>	<u>0.00</u>	<u>0.00</u>	<u>56,850.00</u>	<u>0.00</u>
*** TOTAL REVENUES ***	<u>203,900.00</u>	<u>11,210.83</u>	<u>0.00</u>	<u>110,221.05</u>	<u>0.00</u>	<u>93,678.95</u>	<u>54.06</u>
<u>EXPENDITURE SUMMARY</u>							
09-STREET & STORM	<u>203,900.00</u>	<u>2,500.00</u>	<u>0.00</u>	<u>137,052.00</u>	<u>10,000.00</u>	<u>56,848.00</u>	<u>72.12</u>
*** TOTAL EXPENDITURES ***	<u>203,900.00</u>	<u>2,500.00</u>	<u>0.00</u>	<u>137,052.00</u>	<u>10,000.00</u>	<u>56,848.00</u>	<u>72.12</u>
** REVENUE OVER(UNDER) EXPENDITURES **	<u>0.00</u>	<u>8,710.83</u>	<u>0.00</u>	<u>(26,830.95)</u>	<u>(10,000.00)</u>	<u>36,830.95</u>	<u>0.00</u>

CITY OF CHICKASHA
 FINANCIAL STATEMENT (UNAUDITED)
 AS OF: FEBRUARY 28TH, 2026

56 -CEMETERY CARE
 FINANCIAL SUMMARY

% OF YEAR COMPLETED: 66.67

	CURRENT BUDGET	CURRENT PERIOD	PRIOR YEAR EXPENSE	Y-T-D ACTUAL	Y-T-D ENCUMBRANCE	BUDGET BALANCE	% OF BUDGET
<u>REVENUE SUMMARY</u>							
CEMETERY	19,300.00	1,593.75	0.00	19,230.00	0.00	70.00	99.64
INTEREST	13,500.00	593.04	0.00	18,979.08	0.00	(5,479.08)	140.59
PRIOR YEAR FUND BALANCE C	<u>152,200.00</u>	<u>0.00</u>	<u>0.00</u>	<u>0.00</u>	<u>0.00</u>	<u>152,200.00</u>	<u>0.00</u>
*** TOTAL REVENUES ***	<u>185,000.00</u>	<u>2,186.79</u>	<u>0.00</u>	<u>38,209.08</u>	<u>0.00</u>	<u>146,790.92</u>	<u>20.65</u>
<u>EXPENDITURE SUMMARY</u>							
06-CEMETERY MAINT.-C	<u>185,000.00</u>	<u>4,147.04</u>	<u>0.00</u>	<u>41,276.40</u>	<u>7,000.00</u>	<u>136,723.60</u>	<u>26.10</u>
*** TOTAL EXPENDITURES ***	<u>185,000.00</u>	<u>4,147.04</u>	<u>0.00</u>	<u>41,276.40</u>	<u>7,000.00</u>	<u>136,723.60</u>	<u>26.10</u>
** REVENUE OVER (UNDER) EXPENDITURES **	0.00	(1,960.25)	0.00	(3,067.32)	(7,000.00)	10,067.32	0.00

FINANCIAL STATEMENT (UNAUDITED)

AS OF: FEBRUARY 28TH, 2026

57 -CIP-2024 CAPITAL SALESTAX

FINANCIAL SUMMARY

% OF YEAR COMPLETED: 66.67

	CURRENT BUDGET	CURRENT PERIOD	PRIOR YEAR EXPENSE	Y-T-D ACTUAL	Y-T-D ENCUMBRANCE	BUDGET BALANCE	% OF BUDGET
<u>REVENUE SUMMARY</u>							
TRANSFER OTHER FUNDS-EQU	5,816,719.00	503,790.63	0.00	3,628,806.17	0.00	2,187,912.83	62.39
INTEREST	<u>6,219.00</u>	<u>1,119.51</u>	<u>0.00</u>	<u>12,854.93</u>	<u>0.00</u>	(<u>6,635.93</u>)	<u>206.70</u>
*** TOTAL REVENUES ***	<u>5,822,938.00</u>	<u>504,910.14</u>	<u>0.00</u>	<u>3,641,661.10</u>	<u>0.00</u>	<u>2,181,276.90</u>	<u>62.54</u>
<u>EXPENDITURE SUMMARY</u>							
57-2024 CAPITAL SALES TAX	<u>5,822,938.00</u>	<u>0.00</u>	<u>0.00</u>	<u>2,015,441.75</u>	<u>0.00</u>	<u>3,807,496.25</u>	<u>34.61</u>
*** TOTAL EXPENDITURES ***	<u>5,822,938.00</u>	<u>0.00</u>	<u>0.00</u>	<u>2,015,441.75</u>	<u>0.00</u>	<u>3,807,496.25</u>	<u>34.61</u>
** REVENUE OVER (UNDER) EXPENDITURES **	<u>0.00</u>	<u>504,910.14</u>	<u>0.00</u>	<u>1,626,219.35</u>	<u>0.00</u>	(<u>1,626,219.35</u>)	<u>0.00</u>

CITY OF CHICKASHA
 FINANCIAL STATEMENT (UNAUDITED)
 AS OF: FEBRUARY 28TH, 2026

61 -WATER METER FUND
 FINANCIAL SUMMARY

% OF YEAR COMPLETED: 66.67

CURRENT BUDGET	CURRENT PERIOD	PRIOR YEAR EXPENSE	Y-T-D ACTUAL	Y-T-D ENCUMBRANCE	BUDGET BALANCE	% OF BUDGET
----------------	----------------	--------------------	--------------	-------------------	----------------	-------------

REVENUE SUMMARY

INTEREST	<u>6,178.00</u>	<u>456.59</u>	<u>0.00</u>	<u>8,989.98</u>	<u>0.00</u>	(<u>2,811.98</u>)	<u>145.52</u>
*** TOTAL REVENUES ***	<u>6,178.00</u>	<u>456.59</u>	<u>0.00</u>	<u>8,989.98</u>	<u>0.00</u>	(<u>2,811.98</u>)	<u>145.52</u>

EXPENDITURE SUMMARY

36-LINE MAINTENANCE-BT	<u>6,178.00</u>	<u>0.00</u>	<u>0.00</u>	<u>0.00</u>	<u>0.00</u>	<u>6,178.00</u>	<u>0.00</u>
*** TOTAL EXPENDITURES ***	<u>6,178.00</u>	<u>0.00</u>	<u>0.00</u>	<u>0.00</u>	<u>0.00</u>	<u>6,178.00</u>	<u>0.00</u>
** REVENUE OVER (UNDER) EXPENDITURES **	<u>0.00</u>	<u>456.59</u>	<u>0.00</u>	<u>8,989.98</u>	<u>0.00</u>	(<u>8,989.98</u>)	<u>0.00</u>

CITY OF CHICKASHA
 FINANCIAL STATEMENT (UNAUDITED)
 AS OF: FEBRUARY 28TH, 2026

64 -POLICE BOND FUND
 FINANCIAL SUMMARY

% OF YEAR COMPLETED: 66.67

	CURRENT BUDGET	CURRENT PERIOD	PRIOR YEAR EXPENSE	Y-T-D ACTUAL	Y-T-D ENCUMBRANCE	BUDGET BALANCE	% OF BUDGET
<u>REVENUE SUMMARY</u>							
POLICE FINES	103,000.00	41,872.17	0.00	160,621.88	0.00	(57,621.88)	155.94
MISC REVENUES	0.00	0.00	0.00	(10.00)	0.00	10.00	0.00
INTEREST	<u>3,525.00</u>	<u>467.77</u>	<u>0.00</u>	<u>4,756.55</u>	<u>0.00</u>	(<u>1,231.55</u>)	<u>134.94</u>
*** TOTAL REVENUES ***	<u>106,525.00</u>	<u>42,339.94</u>	<u>0.00</u>	<u>165,368.43</u>	<u>0.00</u>	(<u>58,843.43</u>)	<u>155.24</u>
<u>EXPENDITURE SUMMARY</u>							
03-POLICE DEPARTMENT-PS	<u>106,525.00</u>	<u>28,013.74</u>	<u>0.00</u>	<u>121,964.43</u>	<u>7,088.54</u>	(<u>22,527.97</u>)	<u>121.15</u>
*** TOTAL EXPENDITURES ***	<u>106,525.00</u>	<u>28,013.74</u>	<u>0.00</u>	<u>121,964.43</u>	<u>7,088.54</u>	(<u>22,527.97</u>)	<u>121.15</u>
** REVENUE OVER (UNDER) EXPENDITURES **	<u>0.00</u>	<u>14,326.20</u>	<u>0.00</u>	<u>43,404.00</u>	<u>(7,088.54)</u>	(<u>36,315.46</u>)	<u>0.00</u>

CITY OF CHICKASHA
 FINANCIAL STATEMENT (UNAUDITED)
 AS OF: FEBRUARY 28TH, 2026

68 -WATER RESOURCE FUND
 FINANCIAL SUMMARY

% OF YEAR COMPLETED: 66.67

	CURRENT BUDGET	CURRENT PERIOD	PRIOR YEAR EXPENSE	Y-T-D ACTUAL	Y-T-D ENCUMBRANCE	BUDGET BALANCE	% OF BUDGET
<u>REVENUE SUMMARY</u>							
UTILITY SERVICE	90,000.00	7,449.81	0.00	56,851.49	0.00	33,148.51	63.17
INTEREST	<u>13,115.00</u>	<u>709.86</u>	<u>0.00</u>	<u>20,108.52</u>	<u>0.00</u>	<u>(6,993.52)</u>	<u>153.32</u>
*** TOTAL REVENUES ***	<u>103,115.00</u>	<u>8,159.67</u>	<u>0.00</u>	<u>76,960.01</u>	<u>0.00</u>	<u>26,154.99</u>	<u>74.64</u>
<u>EXPENDITURE SUMMARY</u>							
68-WATER RESOURCES	<u>103,115.00</u>	<u>0.00</u>	<u>0.00</u>	<u>0.00</u>	<u>0.00</u>	<u>103,115.00</u>	<u>0.00</u>
*** TOTAL EXPENDITURES ***	<u>103,115.00</u>	<u>0.00</u>	<u>0.00</u>	<u>0.00</u>	<u>0.00</u>	<u>103,115.00</u>	<u>0.00</u>
** REVENUE OVER (UNDER) EXPENDITURES **	<u>0.00</u>	<u>8,159.67</u>	<u>0.00</u>	<u>76,960.01</u>	<u>0.00</u>	<u>(76,960.01)</u>	<u>0.00</u>

CITY OF CHICKASHA
 FINANCIAL STATEMENT (UNAUDITED)
 AS OF: FEBRUARY 28TH, 2026

71 -COMBINED INSURANCE
 FINANCIAL SUMMARY

% OF YEAR COMPLETED: 66.67

	CURRENT BUDGET	CURRENT PERIOD	PRIOR YEAR EXPENSE	Y-T-D ACTUAL	Y-T-D ENCUMBRANCE	BUDGET BALANCE	% OF BUDGET
<u>REVENUE SUMMARY</u>							
INSURANCE	45,000.00	0.00	0.00	32,838.12	0.00	12,161.88	72.97
INTEREST	<u>15,000.00</u>	<u>2,943.68</u>	<u>0.00</u>	<u>30,896.14</u>	<u>0.00</u>	<u>15,896.14</u>	<u>205.97</u>
*** TOTAL REVENUES ***	60,000.00	2,943.68	0.00	63,734.26	0.00	3,734.26	106.22
<u>EXPENDITURE SUMMARY</u>							
71-COMBINED INSURANCE-CR	<u>60,000.00</u>	<u>8,557.59</u>	<u>0.00</u>	<u>14,771.59</u>	<u>0.00</u>	<u>45,228.41</u>	<u>24.62</u>
*** TOTAL EXPENDITURES ***	60,000.00	8,557.59	0.00	14,771.59	0.00	45,228.41	24.62
** REVENUE OVER (UNDER) EXPENDITURES **	0.00	(5,613.91)	0.00	48,962.67	0.00	(48,962.67)	0.00

FINANCIAL STATEMENT (UNAUDITED)

AS OF: FEBRUARY 28TH, 2026

72 -COMPENSATED ABSENCES FUND
FINANCIAL SUMMARY

% OF YEAR COMPLETED: 66.67

	CURRENT BUDGET	CURRENT PERIOD	PRIOR YEAR EXPENSE	Y-T-D ACTUAL	Y-T-D ENCUMBRANCE	BUDGET BALANCE	% OF BUDGET
<u>REVENUE SUMMARY</u>							
INSURANCE	100,618.00	0.00	0.00	55,300.00	0.00	45,318.00	54.96
INTEREST	<u>0.00</u>	<u>181.07</u>	<u>0.00</u>	<u>2,007.44</u>	<u>0.00</u>	(<u>2,007.44</u>)	<u>0.00</u>
*** TOTAL REVENUES ***	<u>100,618.00</u>	<u>181.07</u>	<u>0.00</u>	<u>57,307.44</u>	<u>0.00</u>	<u>43,310.56</u>	<u>56.96</u>
<u>EXPENDITURE SUMMARY</u>							
72-COMPENSATED ABSENCES	<u>100,618.00</u>	<u>2,124.27</u>	<u>0.00</u>	<u>117,932.55</u>	<u>0.00</u>	(<u>17,314.55</u>)	<u>117.21</u>
*** TOTAL EXPENDITURES ***	<u>100,618.00</u>	<u>2,124.27</u>	<u>0.00</u>	<u>117,932.55</u>	<u>0.00</u>	(<u>17,314.55</u>)	<u>117.21</u>
** REVENUE OVER(UNDER) EXPENDITURES **	<u>0.00</u>	(<u>1,943.20</u>)	<u>0.00</u>	(<u>60,625.11</u>)	<u>0.00</u>	<u>60,625.11</u>	<u>0.00</u>

CHICKASHA

Meeting Type: Council Agenda 4-6-2026

Meeting Date: 4/6/2026

Department: Finance

Agenda Item No. 4.d.

AGENDA ITEM: Approval of Quote from Tyler Technologies for 3 additional credit card readers

I. BACKGROUND/DESCRIPTION:

Consideration and possible action to approve a quote from Tyler Technologies for the purchase of three (3) EMV card readers for Tyler Payments in the amount of \$1,587 (one-time cost), plus an annual PCI service fee of \$540 (\$180 per device), as outlined in Quote No. 2026-597179-B1S2D5

II. RECOMMENDED ACTION:

Staff recommends approval of the quote from Tyler Technologies for the purchase of three (3) EMV card readers and associated PCI service fees to support the transition to a new third-party credit card merchant services provider for the MyGov software utilized by the Community Development Department. This purchase is necessary to ensure continued, secure processing of in-person credit card payments and uninterrupted service to the public.

III. FISCAL INFORMATION - Paid for from the general fund out of the current fiscal year budget.

IV. FUND INFORMATION:

Dept. Director: Rich Edwards, Finance Director	Fund	Account	Amount
	(To)		
	FUND	ACCOUNT	AMOUNT
Meeting Date: April 6, 2026	(From) 11-514-5201-020		

V. ATTACHMENTS:

1. Credit Card Reader Quote



Billing Address:
 CHICKASHA, OK CITY OF
 TRACEY AUSTIN
 117 N 4TH ST
 CHICKASHA OK 73018-2601

Shipping Address
 City of Chickasha
 117 N 4th St

 Chickasha OK 73018-2601

Quoted By Matthew Beltram
 Quote Expiration 8/25/26
 Quote Name 2 Additional Card Devices

Third Party Software & Hardware		Quantity	Unit Price	Extended Price	Annual
Description					
Tyler One					
Payments					
Payments EMV Card Reader Purchase		3	\$ 529	\$ 1,587	\$ 0
PCI Service Fee (Per Device)		3	\$ 180	\$ 0	\$ 540
TOTAL:				\$ 1,587	\$ 540

Summary	One Time Fees	Recurring Fees
Total Third Party Hardware, Software, Services	\$ 1,587	\$ 540
Total Tyler Services		
Summary Total	\$ 1,587	\$ 540

Comments

Work will be delivered remotely unless otherwise noted in this agreement.

Expenses associated with onsite services are invoiced as incurred according to Tyler's standard business travel policy.

SaaS is considered a term of one year unless otherwise indicated.

Client agrees that items in this sales quotation are, upon Client's signature or approval of same, hereby added to the existing agreement ("Agreement") between the parties and subject to its terms. Additionally, payment for said items, as applicable but subject to any listed assumptions herein, shall conform to the following terms, subject to payment terms in an agreement, amendment, or similar document in which this sales quotation is included:

- License fees for Tyler and third-party software are invoiced upon the earlier of (i) delivery of the license key or (ii) when Tyler makes such software available accessible.
- Fees for hardware are invoiced upon delivery.
- Fees for year one of hardware maintenance are invoiced upon delivery of the hardware.
- Annual Maintenance and Support fees are first payable when Tyler makes the software accessible to the Client, and SaaS fees, Hosting fees, and Subscription fees are first payable on the first day of the month following the date this quotation was signed (or if later, the commencement of the agreement's initial term). Any such fees are prorated to align with the applicable term under the agreement, with renewals invoiced annually thereafter in accord with the agreement.

Fees for services included in this sales quotation shall be invoiced as indicated below.

- Implementation and other professional services fees shall be invoiced as delivered.
- Client has six months to use the services. If Client does not use the services within six months, Tyler may remove the unused services or issue a new quote to provide services at then-current rates.
- Fixed-fee Business Process Consulting services shall be invoiced 50% upon delivery of the Best Practice Recommendations, by module, and 50% upon delivery of custom desktop procedures, by module.
- Fixed-fee conversions are invoiced 50% upon initial delivery of the converted data, by conversion option, and 50% upon Client acceptance to load the converted data into Live/Production environment, by conversion option. Where conversions are quoted as estimated, Tyler will invoice Client the actual services delivered on a time and materials basis.

- Except as otherwise provided, other fixed price services are invoiced upon complete delivery of the service. For the avoidance of doubt, where "Project Planning Services" are provided, payment shall be invoiced upon delivery of the Implementation Planning document. Dedicated Project Management services, if any, will be invoiced monthly in arrears, beginning on the first day of the month immediately following initiation of project planning.
- If Client has purchased any change management services, those services will be invoiced in accordance with the Agreement.
- Notwithstanding anything to the contrary stated above, the following payment terms shall apply to fees specifically for migrations: Tyler will invoice Client 50% of any Migration Services Fees listed above upon Client approval of the product suite migration schedule. The remaining 50%, by line item, will be billed upon the go-live of the applicable product suite. Tyler will invoice Client for any Project Management Fees listed above upon the go-live of the first product suite. Annual SaaS Fees will be invoiced upon availability of the hosted environment.

Any SaaS or hosted solutions added to an agreement containing Client-hosted Tyler solutions are subject to Tyler's SaaS Services terms found here: <https://www.tylertech.com/terms/tyler-saas-services>.

Unless otherwise indicated in the contract or amendment thereto, pricing for optional items will be held for six (6) months from the Quote date or the Effective Date of the Contract, whichever is later.

Customer Approval: _____ Date: _____

Print Name: _____ P.O.#: _____

CHICKASHA

Meeting Type: Council Agenda 4-6-2026

Meeting Date: 4/6/2026

Department: Police Department

Agenda Item No. 4.e.

AGENDA ITEM: Acceptance of a Memorandum of Understanding for Animal Welfare Conference Scholarship

I. BACKGROUND/DESCRIPTION:

From May 7–9 in Salt Lake City, Utah, the Best Friends Network Partners will host a National Animal Welfare Conference. Animal Welfare Supervisor Layce Kepp has been awarded the Best Friends Network Scholarship to attend the conference. The scholarship covers the cost of airfare, hotel, registration and meals and requires an MOU to be executed by the City.

II. RECOMMENDED ACTION:

Staff recommends acceptance of the scholarship for Animal Welfare Supervisor Kepp and asks the Mayor execute the same.

III. FISCAL INFORMATION -

IV. FUND INFORMATION:

Dept. Director: Traye Alexander Assistant Chief of Police	Fund	Account	Amount
	(To)		
	FUND	ACCOUNT	AMOUNT
Meeting Date: 04.06.26	(From)		

V. ATTACHMENTS:

- 20260331134331080

Memorandum of Understanding

Best Friends Animals Society ("Best Friends") is a 501(c)(3) nonprofit corporation based in Kanab, Utah, whose mission is No More Homeless Pets[®]. Best Friends feels privileged to help save lives by working with organizations and agencies by providing funding for specific projects and/or needs. This document is to clarify in writing the roles that the organization listed below agrees to upon receipt of this one-time financial award ("Scholarship").

Recipient is a 501(c)(3) nonprofit animal welfare charity or a municipal shelter and has been selected to receive a Scholarship for the below intended purpose. The funds shall be utilized for terms set below and will be disbursed only upon receipt of this document and a copy of the Recipient's IRS Form W9 (if applicable). This document and Recipient's IRS Form W9 must be received by Best Friends by April 15, 2026 for Recipient to be provided this Scholarship.

This Memorandum of Understanding ("MOU") will govern the terms of the Scholarship. Each party shall be referred to herein individually as a "Party," and collectively as the "Parties."

In consideration of the receipt of this Scholarship, Recipient agrees to the following terms:

Scholarship Amount and Terms:

Name of Recipient Organization: Chickasha Animal Control
EIN #: 73-6005139
Scholarship in the amount of: \$2,200.00

Recipient Responsibilities:

- Recipient agrees that the Scholarship is provided for one (1) staff member and/or volunteer ("Recipient's Representative/s") to attend the Best Friends National Conference, May 7-9, 2026 in Salt Lake City, Utah (the "Educational Opportunity").
- Recipient agrees that the Scholarship will be used specifically for the purpose of subsidizing the costs incurred by Recipient due to the Recipient's Representative/s attending the Educational Opportunity. Recipient understands and agrees that Best Friends has no responsibility for any other costs that may be incurred by Recipient and/or Recipient's Representative/s associated with Recipient Representative/s travel to or participation in the Educational Opportunity.
- 100% of Event registration costs will be covered by a registration code provided by Best Friends.
- Recipient's Representative/s will attend at least 75% or more of the sessions offered at the Educational Opportunity
- Understands and agrees that if Recipient's Representative(s) do not attend the Educational Opportunity, then Recipient will be obligated to pay Best Friends back for the full amount of the Scholarship.
- Recipient will submit confirmation of registration for the Educational Opportunity to Best Friends via email to Best Friends designed email address once registration has been completed.

MOU Restrictions:

In addition to abiding by the requirement that the funds be used in furtherance of the project described in Recipient's obligations, Recipient specifically agrees that no portion of the funds will be used for any of the following: (i) to lobby or otherwise attempt to influence legislation; (ii) to influence outcome of any specific public election or participate or intervene in any political

campaign on behalf of any candidate for public office or conduct, directly or indirectly; (iii) to support or oppose any elected official or candidate for public office or on any particular issue.

Termination by Best Friends:

Best Friends may immediately terminate this Agreement without penalty or any further obligation by sending an email to Recipient. Such event shall not constitute an event of default. All obligations of Best Friends will cease upon the date of termination. Recipient understands and agrees that Best Friends is not responsible for any costs incurred by Recipient and/or Recipient's Representative/s if Best Friends terminates this MOU prior to Best Friends payment to Recipient.

Release:

To the full extent permitted by applicable law, the Recipient, its directors, officers, employees, representatives, agents, successors and assigns, agrees never to bring a claim or suit against BFAS relating to this MOU and the Educational Opportunity and its receipt of financial assistance funds. Recipient agrees BFAS and its directors, officers, employees, representatives, agents, successors and assigns are not responsible for any of the decisions, plans, guidelines, work, or activities related to or arising from the Educational Opportunity. Recipient releases BFAS and its directors, founders, employees, officers, agents, representatives, contractors, volunteers, successors and assigns from all liability arising from any work or activities related to the Educational Opportunity. Recipient understands this agreement discharges BFAS and its directors, founders, employees, officers, agents, representatives, contractors, volunteers, successors and assigns from any liability to Recipient with respect to bodily injury, personal injury, illness, death, property damage or other loss of any kind or nature whatsoever, direct or indirect, known or unknown, that may result as a result of Recipient's work, participation and activities and of Recipient's Representatives participation in the Educational Opportunity.

Indemnity Agreement:

To the full extent permitted by applicable law, Recipient and its directors, officers, agents, employees, representatives, successors and assigns, agree to indemnify and hold BFAS harmless for all bodily injury, personal injury, illness, death, property damage or other losses of any kind or nature whatsoever, direct or indirect, known or unknown, including attorney's fees and costs of litigation that result to anyone else or any other entity because of actions or omissions related to this MOU or the Educational Opportunity. This includes lone acts or omissions by Recipient as well as the combined acts of Recipient with others.

By signing below, the Parties acknowledge that they have read this MOU and indicate their intent to sign and be bound by the terms and conditions herein. If signing electronically, each Party agrees that their electronic signatures are intended to authenticate this writing and to have the same force and effect as a manual signature for purposes of validity, enforceability, and admissibility.

Agreed to by:

Date:

Electronic signature by authorized signer for Recipient

Agreed to by:

Date:

Electronic signature by authorized signer for Best Friends Animal Society

CHICKASHA

Meeting Type: Council Agenda 4-6-2026

Meeting Date: 4/6/2026

Department: Police Department

Agenda Item No. 4.f.

AGENDA ITEM: Approve purchase of a 10x20 Lofted Barn for the Animal Welfare Division

I. BACKGROUND/DESCRIPTION:

The Chickasha Animal Welfare Division plans to purchase a 10x20 storage building from Sheds and Trailers of Chickasha.

II. RECOMMENDED ACTION:

Staff recommends that the Mayor reviews and signs the contract for a 10x20 storage shed that the Animal Welfare Division plans to purchase from Sheds and Trailers of Chickasha.

III. FISCAL INFORMATION -

IV. FUND INFORMATION:

Dept. Director: Traye Alexander, Asst. Chief of Police	Fund	Account	Amount
	(To)		
	FUND	ACCOUNT	AMOUNT
Meeting Date: 04-06-2026	(From)		

V. ATTACHMENTS:

1. Sheds and Trailers Contract
2. Chickasha Building Sales (Derksen)
3. 20260331160638803

Sheds and Trailers of Chickasha

617 W. Choctaw Ave

Chickasha, OK. 73018

405.205.3761

March 12, 2026

City of Chickasha

Contract for 10x20 Lofted Barn attached for Signature

Signature indicated with Red Check Mark

SalesRep: John Barber

PREMIER - CASH

Date: 03/12/2026

Shop: Siloam Springs, AR

DEALER NAME: West Valley Buildings-Chickasha

Brochure: 5395

DEALER EMAIL: westvalleybuildings@gmail.com

Phone: 405-222-8234

Inventory #: []

ID: 225832

Description: Lofted Barn Width:10 X Length:20

Customer Information

Name: CITY OF CHICKASHA

Street: 117 N. 4TH STREET

City: CHICKASHA

State: OK

Zip: 73018

Phone #: (405) 222-6093

Alt. Phone: (405) 222-6093

Work Phone: (405) 222-6093

Email: SUSIE.EARNEST@CHICKASHAPD.GOV

Last 4 of Social**: 2212

Delivery Address

Same as Billing

Street: 203 N. GENEVIEVE STREET

City: CHICKASHA

State: OK

Zip: 73018

**Last 4 of Social only needed if customer paying with GreenSky.

© Copyright 2019 Premier Portable Buildings. All Rights Reserved. Unauthorized use is punishable by law.

SalesRep: John Barber **PREMIER - CASH** Date: 03/12/2026
 Shop: S'nam Springs, AR
 Brochure: 5395 DEALER NAME: West Valley Buildings-Chickasha
 DEALER EMAIL: westvalleybuildings@gmail.com Phone: 405-222-8234
 Inventory #: Description: Lofted Barn With 10 X Length 20

© Copyright 2019 Premier Portable Buildings. All Rights Reserved. Unauthorized use is punishable by law.

Building Information - Select Style -

Building Condition: Custom Shop Bu'ld
 Siding Type: Urethane
 Building Style: Lofted Barn
 Size: 10 X 20

Siding Color: Scarlett Red
 Trim Color: Light Stone
 Roof Color: Black

! TWO TONE AVAILABLE IN URETHANE ONLY !
 UPPER COLOR LOWER COLOR

Customer Name: CITY OF CHICKASHA
 Street: 117 N. 4TH STREET
 City: CHICKASHA
 State: OK
 Zip: 73018
 Phone #: (405) 222-6093
 Alt. Phone: (405) 222-6093
 Work Phone: (405) 222-6093
 Email: SUSIE.EARNEST@CHICKASHAPD.GOV

Building Options

Option	Qty	Cost
RTO Assurance 5 yrs		0.00
Building Metal N/A		0.00
Promotional Discount	-1.00	-1,369.00
3/4" FLOOR-NG UPGRADE P/SQF		0.00
0		0.00
0		0.00
0		
0		
0.00%		0.00

Cash Sale *Checks payable to: Premier Portable Buildings.

Sales Price: 6,845.00 Building Cost: 5,876.00
 Option Cost: -969.00 * 50% required on cash sales
 Total (Pre-Tax): 5,876.00 Total Amount Recieved: 5,876.00
 Sales Tax %: 0.00% Payment Method:
 To get a 9% tax rate enter 0.09
 Sales Tax Amount: 0.00 Balance Due: 0.00

Directions / Special Instructions

PLEASE CALL AHEAD FOR DELIVERY, SOMEONE WILL BE THERE TO SHOW PLACEMENT. THEY WILL HAVE BLOCKS AVAILABLE AT DELIVERY. THE SUPERVISOR FOR THIS PROJECT IS LAYCE KEPP WITH ANIMAL CONTROL (405-222-6093) THIS IS A CUSTOM BUILD 10X20 LOFTED BARN.

Premier Portable Buildings and its associates are not responsible for permits, covenant searches, restrictions, setbacks, yard damage, or underground damage. Please contact your local Building Inspector or Homeowners Association for information. It is the customers' responsibility to decide if ground conditions are un-suitable for delivery. Free Delivery covers one trip up to 50 miles one way; over 50 miles are subject to a \$5/mile charge one way, and any additional trips may also incur charges to the customer. *Free Setup* includes leveling, starting with one corner at ground level, up to 3ft with customer supplied blocks.

Balance Dues: Any balance due is to be paid in full at the time of delivery, if there is a damage issue it needs to be stated on the signed delivery sheet and all but 10% of the balance is due at the time of delivery. Customer authorizes Premier to run any credit card on file (if provided) upon delivery of all non RTO purchases unless otherwise stated on the delivery sheet.

Reorder Policy: Customers have 48 hours from the time the contract is signed to make any changes without incurring a cancellation fee of \$300. If changes are made after 48 hours of signing the contract a \$300 fee will be added to the new sales order, this applies to RTO and Cash customers.

Cancel Policy: if you cancel your order within 48 hours of the contract being signed you will be refunded all monies that have been put down. If you cancel your contract after 48 hours of the contract being signed the following applies to a cancellation fee: RTO customers: 8 wide \$100, 10 wide \$150, 12 wide \$250, 14 wide \$750 and 16 wide \$1500. Cash customers you will be refunded all but 10% of the retail selling price of the barn. Premier is not able to refund all money after 48 hours due to permitting issues in your area.

RTO Payment Assurance LLC, upon purchase of assurance plan, RTO Payment Assurance LLC, bears risk of loss to the Purchased Property, except as to loss or damage caused by moisture, scratches, mysterious disappearance, vandalism, abandonment or any other damage intentionally caused by the customer or that results from the customer's willful or wanton misconduct. For damage to or the loss of the Property due to fire, Customer must supply RTO Payment Assurance, LLC, with a copy of an official report evidencing fire, excluding contents.

Disclaimer (Only for On-Lot Used Building Condition). The building you are purchasing is being purchased "As-Is"; therefore, it does not come with any craftsmanship or product warranties and/or guarantees. By signing below, you acknowledge this fact and will not hold Premier Portable Buildings or its associates responsible for the condition of the building or defects in products or craftsmanship for the life of the building.

(Cash Customer) Notice: This agreement offers, for an additional charge, a liability waiver to cover your responsibility for damage to the purchased property. Before deciding whether you purchase the liability damage waiver, you may wish to determine whether your own homeowners or casualty insurance affords you coverage for damage done to the purchased property, and the amount of the deductible under your own insurance coverage. The purchase of this liability damage waiver is not made mandatory and may be declined, customer understands that the waiver fee does not represent the purchase of insurance on the property, but is additional compensation to induce their RTO Payment Assurance, LLC to waive liability, except as set forth above, for damage to or loss of the leased property.

Customer Signature

Premier Buildings

PHONE: 8448791468 EMAIL: kyle@premierbuildings.us

ORDER SHEET (REQUIRED ON ALL ORDERS)

Dealer Name Customer Name
 Building Size X Building Style

Building Diagram (Please draw placement of options here, *Required on ALL Orders*):

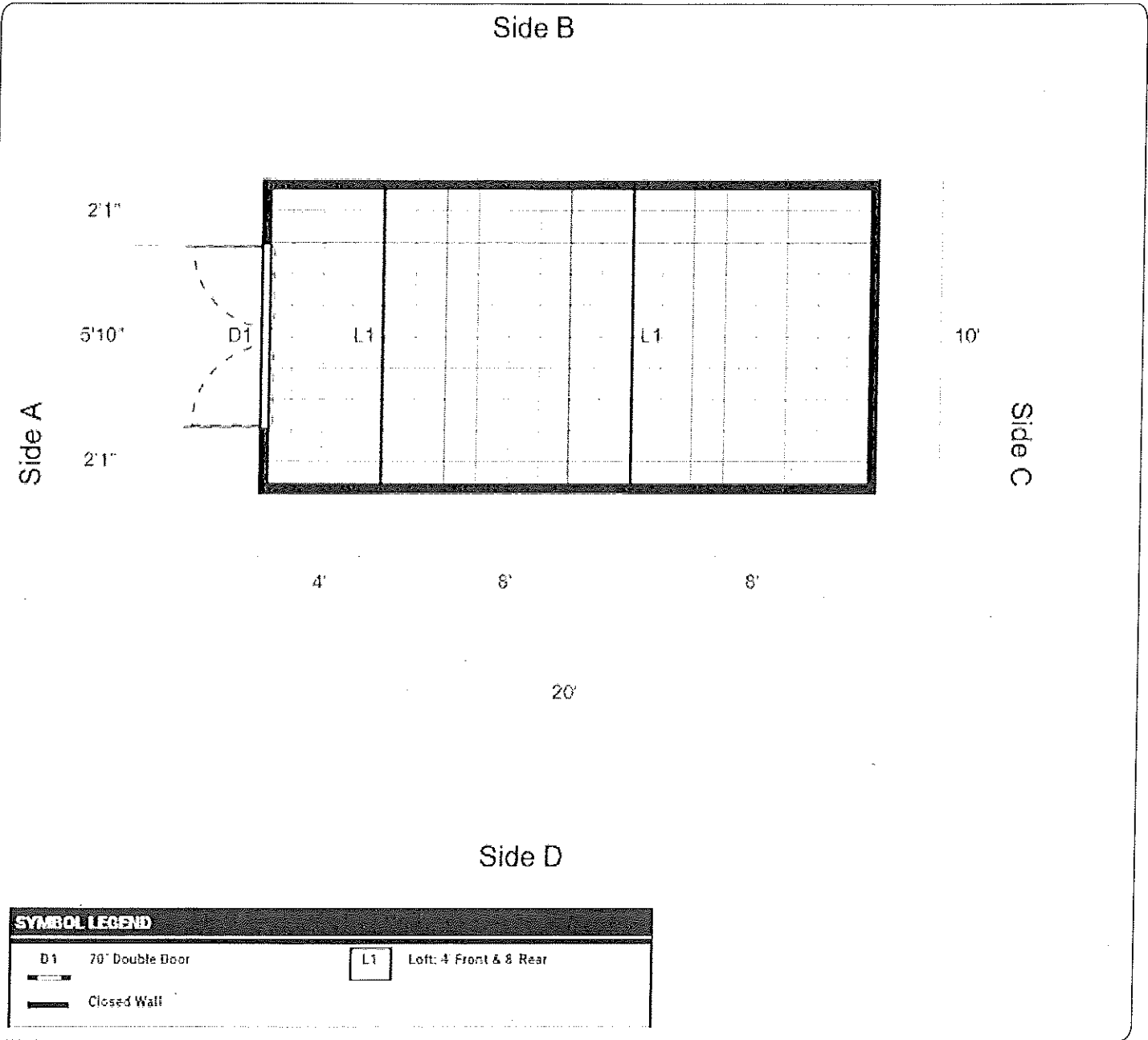

SYMBOL LEGEND	
D1	70" Double Door
	L1 Loft: 4 Front & 8 Rear
	Closed Wall

Written Directions:

Build as shown in brochure with the addition of 3/4" premium flooring. This will be a Custom Build 10x20 Lofted Barn with Scarlett Red Siding, Light Stone Trim, Black Roof with (upgraded 3/4" Premium Flooring)

Customer Initials

Premier Portable Buildings
 317 East State Line, South Fulton, TN 38257 PHONE 1-844-879-1468
 Email all orders to orders@premierbuildings.us

© Copyright 2019 Premier Portable Buildings. All Rights Reserved. Unauthorized use is punishable by law.

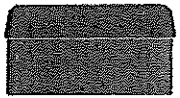
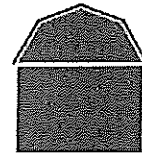
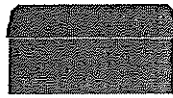
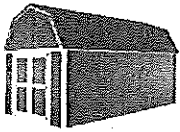

**10x20 Lofted Barn
Scarlett Red Siding
Light Stone Trim
Black Roof
Upgraded 3/4" Premium flooring**

Premier Buildings

MAIL PAYMENTS TO: 317 East State Line, South Fulton TN 38237

PHONE: 8448791468 EMAIL: kyle@premierbuildings.us WEBSITE:

CAPTURE FORMS OF ID (REQUIRED)

Please use the fields on this page to capture images for ID verification. ID ca included but not limited to Drivers License, Passport, Gym Membership Card, Credit Card, Debit Card, voided Check, Insurance Card, etc. One form MUST be a photo form of identification

First Form of ID must be PHOTO ID. I.E. Drivers License, Passport, etc.:

Second Form of ID. Check, Gym Card, etc.:

Premier Portable Buildings
317 East State Line, South Fulton, TN 38257
PHONE 1-844-879-1468

Email all orders to orders@premierbuildings.us

Purchase Order Form
Premier Portable Buildings

Please print

PO#: 20-22212
Company: City of Chickasha
Contact/Supervisor Name: Layce Kepp
Address: mailing: 117 N. 4th St, Chickasha
Email Address to send the invoice: susie.earnest@chickashapd.gov
Amount to pay from the PO: \$5,876.00
Tax exempt: YES / NO Tax Exempt #: 73-6005139
Please include Tax Exempt form with order
PO Form: YES / NO If Yes please include with this form

Layce Kepp
Print Name

[Signature]
Sign Name

[Signature]
Dealer Signature

3/12/20
Date

Delivery address: 203 N. Genevieve St.
Chickasha, OK
73018

Sheds and Trailers of Chickasha
617 W. Choctaw Ave, Chickasha OK. 73018
405.205.3761
www.shedsofchickasha.com

January 9, 2026

Quote: City of Chickasha

Layce Graham, Animal Control Supervisor
2001 W. Iowa Ave Chickasha, OK. 73018
layce.graham@chickashapd.org

10x20 Lofted Barn with 70" Double Door, ¾" Premium Flooring, Base 4x6 Pressure Treated Skids, 3/8" Vertical Urethane Siding, Sidewall Height 6'6", Lofts 4' Front, 8' Rear, Roof material: 30-Year Metal. Siding Color Scarlett Red, Trim Color Light Stone, Roof Color Black.

10x20 Lofted Barn	\$6,845.00
Upgraded ¾" Flooring	400.00
January 20% off Sale	<u>-\$1,369.00</u>
Total Price	\$5,876.00

(Price includes delivery and set up)



Date: 03/31/2026

Chickasha Building Sales
 1001 East Choctaw
 Chickasha
 Oklahoma 73018
 (405) 819-6892

CUSTOMER RECEIPT - 01182006

City Of Chickasha
 117 North 4th Street
 Chickasha
 OK 73018
 Home: (580) 861-2515
 layce.graham@chickashapd.gov

DELIVER TO:
 117 North 4th Street
 Chickasha
 Oklahoma 73018
 Mobile:

ORDER SUMMARY - CASH SALE			NEW
PRODUCT & OPTIONS	SALES PRICE	QTY	TOTAL PRICE
LOFTED BARN 10x20	\$6,425.00	1	\$6,425.00
3/4" Flooring Upgrade (Formerly Avantech)	\$1.25	200	\$250.00
72" Double Shop Built Doors (Two 36") (Included)	\$0.00	1	\$0.00
Trim Color - Cotton Paint	\$0.00	1	\$0.00
Roof Color - Black Metal	\$0.00	1	\$0.00
Siding Color - Barn Red Paint	\$0.00	1	\$0.00
Discount			\$667.50
Total Pretax			\$6,007.50
Total Tax			\$0.00
Total Price			\$6,007.50
Total Payments Received			\$0.00
Net Amount Due			\$6,007.50
PAYMENTS SUMMARY			
Payment Type	Payment Details	Payment Date	Payment Amount
Total Payment Amount			\$0.00

Please make checks Payable to Derksen Portable Buildings

Tax rate may change (subject to applicable tax).

All sales are subject to final approval by Derksen Portable Buildings Corporate Offices.

Derksen Portable Buildings and its agents are NOT responsible for permits, setbacks, restrictions, or covenants. Please contact your local codes department or Homeowners Association. It is up to the customer to decide whether ground conditions are suitable for delivery. Derksen Buildings is NOT responsible for yard or driveway damage. Free delivery and set up includes ONE TRIP. Additional trips may incur CHARGES to the customer. I, the customer, have read the disclosure, Terms And Conditions Of Sale and fully accept the terms provided therein. First 50 miles Free Delivery (From Lot Thereafter \$4.00 Per Mile). Any cancellation is subject to a restocking fee.

Please Attach a copy of valid identification.

Customer Signature _____



SUNRISE SHEDS, LLC
1126 E Main St
Prague, OK 74864
Phone: 405-567-1335
Email: sunriseshedsok@gmail.com

10x20x7 Loft Barn

Standard 4ft loft at either end

Arizonite walls, Bran Muffin trim

Upgraded to 7' wall

Radlant Barrier Roof

Black shingles

Delivery included

\$6,697.30 No tax

5 Blocks are included with the sale of the building, if extra blocks are needed and Sunrise Sheds provides the blocks, there will be a charge of \$5.00 per extra block. If the customer provides the extra blocks, there will be a Labor Charge of \$2.50 per block used.

CHICKASHA

Meeting Type: Council Agenda 4-6-2026

Meeting Date: 4/6/2026

Department: Police Department

Agenda Item No. 4.g.

AGENDA ITEM: Approve Tyler Technologies Interface Agreement for DigiTicket imports

I. BACKGROUND/DESCRIPTION:

In November 2025, Council approved the Police Department to transition to digital ticket writing with DigiTicket / Saltus Technologies. We are ready to move to Stage 2 and create the Interface for DigiTicket to upload tickets automatically to our Municipal Court Software. An Interface is required through Tyler Technologies.

II. RECOMMENDED ACTION:

Approve the Interface Agreement with Tyler Technologies and authorize the Mayor to execute the same.

III. FISCAL INFORMATION -

IV. FUND INFORMATION:

Dept. Director: Goebel Music, #300 Chief of Police	Fund	Account	Amount
	(To)		
Meeting Date: 04.06.2026	FUND	ACCOUNT	AMOUNT
	(From) 11-503-5302-019		\$4,250.00

V. ATTACHMENTS:

1. Chickasha, OK - DigiTicket Interface



Sales Quotation For:
 CHICKASHA, OK CITY OF
 TRACEY AUSTIN
 CHICKASHA OK 73018-2601

Quoted By Audra Chandler
 Quote Expiration 4/30/26
 Quote Name Citation Issuing Device
 Third-Party Interface -
 DigiTicket

Tyler Software		License Total	Annual Maintenance
Description			
Municipal Justice			
Municipal Justice 9 Suite			
Citation Issuing Device Third-Party Interface		\$ 4,000	\$ 1,000
TOTAL:		\$ 4,000	\$ 1,000

Services		
Description	Hours/Units	Extended Price
Other Services		
Project Management	1	\$ 250

TOTAL:

\$ 250

Summary

Total Tyler Software

One Time Fees

\$ 4,000

Recurring Fees

\$ 1,000

Total Tyler Services

\$ 250

Summary Total

\$ 4,250

\$ 1,000

Comments

Work will be delivered remotely unless otherwise noted in this agreement.

Expenses associated with onsite services are invoiced as incurred according to Tyler's standard business travel policy.

SaaS is considered a term of one year unless otherwise indicated.

Client agrees that items in this sales quotation are, upon Client's signature or approval of same, hereby added to the existing agreement ("Agreement") between the parties and subject to its terms. Additionally, payment for said items, as applicable but subject to any listed assumptions herein, shall conform to the following terms, subject to payment terms in an agreement, amendment, or similar document in which this sales quotation is included:

- License fees for Tyler and third-party software are invoiced upon the earlier of (i) delivery of the license key or (ii) when Tyler makes such software available accessible.
- Fees for hardware are invoiced upon delivery.
- Fees for year one of hardware maintenance are invoiced upon delivery of the hardware.
- Annual Maintenance and Support fees are first payable when Tyler makes the software accessible to the Client, and SaaS fees, Hosting fees, and Subscription fees are first payable on the first day of the month following the date this quotation was signed (or if later, the commencement of the agreement's initial term). Any such fees are prorated to align with the applicable term under the agreement, with renewals invoiced annually thereafter in accord with the agreement.

Fees for services included in this sales quotation shall be invoiced as indicated below.

- Implementation and other professional services fees shall be invoiced as delivered.
- Client has six months to use the services. If Client does not use the services within six months, Tyler may remove the unused services or issue a new quote to provide services at then-current rates.

- Fixed-fee Business Process Consulting services shall be invoiced 50% upon delivery of the Best Practice Recommendations, by module, and 50% upon delivery of custom desktop procedures, by module.
- Fixed-fee conversions are invoiced 50% upon initial delivery of the converted data, by conversion option, and 50% upon Client acceptance to load the converted data into Live/Production environment, by conversion option. Where conversions are quoted as estimated, Tyler will invoice Client the actual services delivered on a time and materials basis.
- Except as otherwise provided, other fixed price services are invoiced upon complete delivery of the service. For the avoidance of doubt, where "Project Planning Services" are provided, payment shall be invoiced upon delivery of the Implementation Planning document. Dedicated Project Management services, if any, will be invoiced monthly in arrears, beginning on the first day of the month immediately following initiation of project planning.
- If Client has purchased any change management services, those services will be invoiced in accordance with the Agreement.
- Notwithstanding anything to the contrary stated above, the following payment terms shall apply to fees specifically for migrations: Tyler will invoice Client 50% of any Migration Services Fees listed above upon Client approval of the product suite migration schedule. The remaining 50%, by line item, will be billed upon the go-live of the applicable product suite. Tyler will invoice Client for any Project Management Fees listed above upon the go-live of the first product suite. Annual SaaS Fees will be invoiced upon availability of the hosted environment.

Any SaaS or hosted solutions added to an agreement containing Client-hosted Tyler solutions are subject to Tyler's SaaS Services terms found here: <https://www.tylertech.com/terms/tyler-saas-services>.

Unless otherwise indicated in the contract or amendment thereto, pricing for optional items will be held for six (6) months from the Quote date or the Effective Date of the Contract, whichever is later.

Customer Approval: _____ Date: _____

Print Name: _____ P.O.#: _____

CHICKASHA

Meeting Type: Council Agenda 4-6-2026

Meeting Date: 4/6/2026

Department: Administration

Agenda Item No. 4.h.

AGENDA ITEM: Approve the request from the Senior Class Sponsor to conduct the 2026 Senior Car Parade on Monday, May 18, 2026, @ 4:30 p.m.

I. BACKGROUND/DESCRIPTION:

A request has been received from Karlye Weber, CHS Student Council Advisor, to conduct the annual Senior Car Parade, Monday, May 18, 2026 @ 4:30 p.m. beginning at the High School going east on Chickasha Avenue to First Street. This has been an annual event for several years now held for the Senior Class of Chickasha High School.

II. RECOMMENDED ACTION:

Approve the request from the Senior Class Sponsor to conduct the 2026 Senior Car Parade on Monday, May 18, 2026, @ 4:30 p.m.

III. FISCAL INFORMATION -

IV. FUND INFORMATION:

Dept. Director: Susan M. McDaniel, CMC City Clerk	Fund	Account	Amount
	(To)		
	FUND	ACCOUNT	AMOUNT
Meeting Date: April 6, 2026	(From)		

V. ATTACHMENTS:

- 20260331143617962



March 30th, 2026

To Whom It May Concern,

On behalf of Chickasha High School, I am writing to formally request permission to hold our annual Senior Parade on Monday, May 18th. This event has become a meaningful tradition that brings together our students, families, and the greater Chickasha community to celebrate the accomplishments and hard work of our senior class.

We are proposing that the parade take place in the afternoon, with a start time of 4:30 PM. The parade route will be coordinated in collaboration with the Chickasha Police Department and Public Works to ensure public safety and minimize disruption to traffic.

Participation in the parade is voluntary for CHS seniors. Those who choose to participate have the opportunity to decorate their vehicles and travel down Chickasha Avenue, celebrating their achievements and sharing this exciting milestone with the community as they prepare for the next chapter of their lives.

We are committed to working closely with city officials to secure all necessary permits, follow regulations, and ensure a safe and enjoyable event for everyone involved.

We would greatly appreciate your support and approval to proceed with planning. If needed, we would be happy to provide additional details or attend an upcoming city council meeting to answer any questions.

Thank you for your time, consideration, and continued support of Chickasha Public Schools.

Sincerely,

Karlye Weber
CHS Student Council Advisor
karlye.weber@chickasha.k12.ok.us

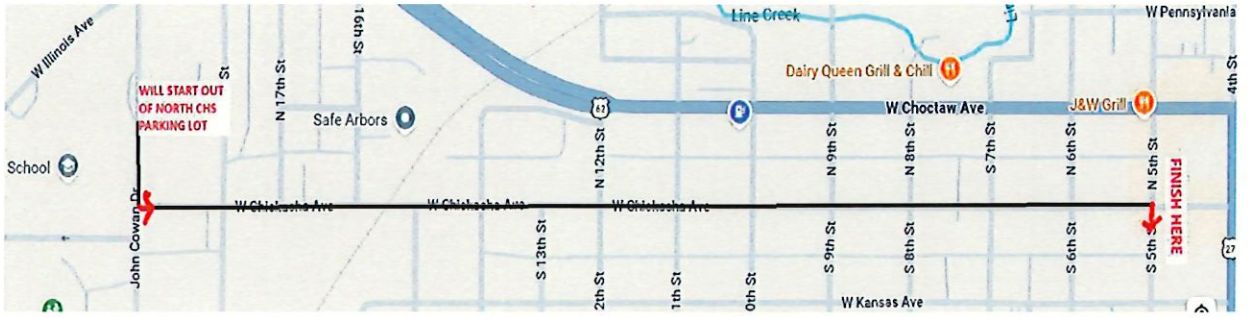

CHICKASHA

Meeting Type: Council Agenda 4-6-2026

Meeting Date: 4/6/2026

Department: Fire Department

Agenda Item No. 4.i.

AGENDA ITEM: Approve the Fireworks Display for Grand Assembly dba Vital Church located at 102 E. Almar Drive on Friday, July 3, 2026.

I. BACKGROUND/DESCRIPTION:

Grand Assembly dba Vital Church, located at 102 E. Almar Drive, has applied for a firework display permit with the Chickasha Fire Department. This display will be presented on Friday, July 3, 2026. This display is provided by a licensed operator who is properly insured.

II. RECOMMENDED ACTION:

Approve the Fireworks Display for Grand Assembly dba Vital Church located at 102 E. Almar Drive on Friday, July 3, 2026.

III. FISCAL INFORMATION -

IV. FUND INFORMATION:

Dept. Director: Tony Samaniego, Fire Chief	Fund	Account	Amount
	(To)		
	FUND	ACCOUNT	AMOUNT
Meeting Date: April 6, 2026	(From)		

V. ATTACHMENTS:

- 20260331163327853

FIREWORKS DISPLAY PERMIT

Date of Application: 02/10/2026

Name of Applicant: Grand Assembly dba Vital Church

Address: 102 E. Almar Drive Chickasha OK 73018

Phone: 405-224-0968 Date of Display: 07/03/2026

Time of Display: 9:00pm Display Location: Grand Assembly dba Vital Church

Lead Operator and State Operator License #: Johnnie Sheppard G081139760

The proposed firing location has been inspected and meets the safety requirements of NFPA 1123 and/or other rules and regulations as required by the authority having jurisdiction. A copy of the product listing must be submitted with the permit.

Signature of Fire Chief or Designee: 

Title: Fire Chief Date: 3/24/26 Telephone: _____

Email: Tony.Samaniego@Chickasha.org Mobile: 405-544-6604

The City of Chickasha and the Chickasha Fire Department accepts no responsibility or liability for pyrotechnic events that do not follow NFPA 1123, NFPA 1126, and NFPA 1124 or for accidents surrounding the pyrotechnic event provided by pyrotechnic vendors or their affiliates.

Grand Assembly dba Vital Church at 102 E. Almar Drive in Chickasha, Oklahoma is requesting a Fireworks Display Permit for our annual Freedom Fest, on our church property, July 3rd 2026.

Our fireworks display would begin at 9pm by lead operator Johnnie Sheppard (state license number G081139760) He will be using a Cobra firing system with a combination of artillery shells, which will be fired in the mortar racks that he has made. The following is a list of the Class C fireworks that he will be using:

- 500gram, 350gram, and 200gram multi shot cakes
- 200gram 16s Bush Red Comet multi shot
- Old iron sides
- Gas money
- Current events
- Red Carpet
- Desperado
- Mt. Rushmore 500gram multi shot
- 1.4 G explosives

If you have any questions, feel free to reach out to me.

Daun Crabb
Office Administrator
Vital Church
405-224-0968

CHICKASHA

Meeting Type: Council Agenda 4-6-2026

Meeting Date: 4/6/2026

Department: City Clerk

Agenda Item No. 4.j.

AGENDA ITEM: Acknowledge receipt of the Economic Development Council of Chickasha, Inc. Check Details for February 2026.

I. BACKGROUND/DESCRIPTION:

II. RECOMMENDED ACTION:

Acknowledge receipt of the Economic Development Council of Chickasha, Inc. Check Details for February 2026.

III. FISCAL INFORMATION -

IV. FUND INFORMATION:

Dept. Director: Susan M. McDaniel, CMC City Clerk	Fund	Account	Amount
	(To)		
	FUND	ACCOUNT	AMOUNT
Meeting Date: April 6, 2026	(From)		

V. ATTACHMENTS:

1. FEBRUARY 2026

Economic Development Council of Chickasha, Inc.

Check Detail February 2026

DATE	TRANSACTION TYPE	NUM	NAME	MEMO/DESCRIPTION	CLR	AMOUNT
101.1 First National 0401						
02/13/2026	Check	ACH	Matthew T Brooks, Jr.	Payroll Research		
02/13/2026	Check	ACH	Jim Cowan	Payroll Director		
02/13/2026	Check	ACH	Cheryl Critchfield	Payroll Operations		
02/18/2026	Check	8161	Blue Cross & Blue Shield	277770 0000975470 Cowan, Brooks, Critchfield		-3,151.93
02/18/2026	Check	8162	Vitus Investments	277770 0000975470 Cowan, Brooks, Critchfield		3,151.93
02/18/2026	Check	8163	Visa	February Storage		-300.00
				February Storage		300.00
				Credit card ending in 9353 Cowan		-2,154.95
				Zoom.com		15.99
				Crazy 8 - business lunch		35.02
				Gannett Media		19.99
				Leadership Oklahoma		155.30
				Roasters - OKSBDC meeting		54.72
				Walmart		40.59
				Ralphies - hosting OSA meeting/lunch		558.00
				DJWSJ		39.99
				Hostgator		24.19
				Hotel Z - Select Oklahoma		253.09
				Hotel Z - Select Oklahoma		543.09
				Hotel Z - Select Oklahoma		8.66
				Landglide		99.99
				Adobe		19.99
				Interurban - business lunch		88.13

Economic Development Council of Chickasha, Inc.

Check Detail February 2026

DATE	TRANSACTION TYPE	NUM	NAME	MEMO/DESCRIPTION	CLR	AMOUNT
				Linked IN		39.99
				Linked In		8.22
				Chickasha Public Schools		150.00
02/18/2026	Check	8164	KSWO	Inv 4163249-1/Marketing		-1,000.00
				Inv 4163249-1/Marketing		1,000.00
02/18/2026	Check	8165	oklahoma Tourism & Recreation	2026 Travel Guide Inv 73-TG26-507		-5,600.00
				2026 Travel Guide Inv 73-TG26-507		5,600.00
02/18/2026	Check	8166	Electrical Technologies, Inc.	Electric work on lights across Chickasha Ave		-720.00
				Electric work on lights across Chickasha Ave		720.00
02/18/2026	Check	8167	Public Service Company of Oklahoma	953-937-571-2-5		-46.34
				953-937-571-2-5		46.34
02/18/2026	Check	8168	Standley Systems	Print cartridge for EDC printer Inv 1911716		-96.60
				Print cartridge for EDC printer Inv 1911716		96.60
02/18/2026	Check	8169	OH18 LLC	Inv 3686		-100.00
				Inv 3686		100.00
02/18/2026	Check	8170	Chickasha Chamber of Commerce	Rent/Utilities		-2,080.94
				Rent/Utilities		2,080.94
02/27/2026	Check	8171	Blue Cross & Blue Shield	0000975470 Cowan Critchfield Brooks		-3,151.93
				0000975470 Cowan Critchfield Brooks		3,151.93
02/27/2026	Check	8172	Mollman Outdoor	Inv Q41649		-250.00
				Inv Q41649		250.00
02/27/2026	Check	8173	Chickasha Chamber of Commerce	Sponsor Leadership Chickasha lunch		-376.30

Economic Development Council of Chickasha, Inc.

Check Detail February 2026

DATE	TRANSACTION TYPE	NUM	NAME	MEMO/DESCRIPTION	CLR	AMOUNT
02/27/2026	Check	8174	Edward Jones Financial	Sponsor Leadership Chickasha lunch		376.30
02/27/2026	Check	8175	Angel, Johnston & Blasingame, P.C.	February contributions Brooks Critchfield		-505.00
02/27/2026	Check	8176	VSP Vision Care	February contributions Brooks Critchfield		-505.00
02/27/2026	Check	8177	Delta Dental of Oklahoma	Inv 58956		-195.00
02/27/2026	Check	ACH	Cheryl Critchfield	Inv 58956		195.00
02/27/2026	Check	ACH	Jim Cowan	30099313 824681510 Cowan Brooks Critchfield		-44.91
02/27/2026	Check	ACH	Matthew T Brooks, Jr.	30099313 824681510 Cowan Brooks Critchfield		44.91
02/27/2026	Check	ACH	Cheryl Critchfield	0016706-0001 Inv 2263594		-180.00
02/27/2026	Check	ACH	Jim Cowan	0016706-0001 Inv 2263594		180.00
02/27/2026	Check	ACH	Cheryl Critchfield	Payroll Operations		
02/27/2026	Check	ACH	Jim Cowan	Payroll Operations		
02/27/2026	Check	ACH	Matthew T Brooks, Jr.	Payroll Director		
02/27/2026	Check	ACH	Matthew T Brooks, Jr.	Landglide reimb		
02/27/2026	Check	ACH	Matthew T Brooks, Jr.	Payroll Research		
02/27/2026	Check	ACH	Matthew T Brooks, Jr.	Payroll Research		

CHICKASHA

Meeting Type: Council Agenda 4-6-2026

Meeting Date: 4/6/2026

Department: City Clerk

Agenda Item No. 4.k.

AGENDA ITEM: Approve the 18th Annual Chickasha Area Arts Council Rock Island Arts Festival and the Annual Food Truck Championship during Friday, October 2nd and Saturday, October 3, 2026, and authorize street closures as requested.

I. BACKGROUND/DESCRIPTION:

The CAAC is requesting the use of Chickasha Avenue from 4th Street to 7th Street beginning at 5:00 p.m. on Thursday, October 1st (to set up and decorate) through Saturday, October 3, 2026. They are asking for the side streets to be blocked from alley to alley, except for 4th Street. They are also requesting that Chickasha Avenue be blocked from First Street to 4th Street beginning at 5:00 p.m. on Friday, October 2nd, so the OFTC can begin setting up for their event scheduled for Saturday, October 3rd. They are also tentatively requesting 7th Street be blocked from alley to alley on Saturday. as well as Chickasha Avenue at 8th Street.

The RIAF/OFTC are requesting a waiver of any associated fees.

City Staff has been and will continue to work closely with both the CAAC and the OFTC to help produce another successful event.

The appropriate Indemnification Agreements and Certificate of Liability Insurance will be obtained for these events.

II. RECOMMENDED ACTION:

Approve the 18th Annual Chickasha Area Arts Council Rock Island Arts Festival and the Annual Oklahoma Food Truck Championship during October 2-3, 2026, and authorize the street closures on Chickasha Avenue and waive any associated fees.

III. FISCAL INFORMATION -

IV. FUND INFORMATION:

Dept. Director:	Fund	Account	Amount
-----------------	------	---------	--------

Susan M. McDaniel, City Clerk	(To)		
	FUND	ACCOUNT	AMOUNT
Meeting Date: April 6, 2026	(From)		

- V. ATTACHMENTS:**
1. 20260401090257248



Chickasha Area Arts Council

Mailing Address – P.O. Box 505 – Chickasha, OK 73023
Physical Address – 521 W. Chickasha Avenue – Chickasha, OK 73018
www.chickashaarts.org 405-448-5036 chickashaarts@gmail.com
Federal Tax ID# 73-1385017

Executive Committee 2026

President
Erin Thompson
ebthompson04@gmail.com

Vice-President
Allison Cofer
allisoncofer1@gmail.com

Secretary
Susan Gearhart
susangearhart@gmail.com

Treasurer
Sue Getman
suegetman@msn.com

Board of Directors 2026

Freddy Baeza
Bryan Bramblett
Allison Cofer
Suzan Colvin
Debbie Fritter
Susan Gearhart
Sue Getman
Terry Godfrey
Adam Heilman
Amber Heilman
Angie Lewis
Sharon Storms
Erin Thompson

March 6, 2026
Chickasha City Council

Chickasha City Manager
117 N. 4th
Chickasha, OK 73018

RE: 18th annual Rock Island Arts Festival

Dear Council,
The Chickasha Area Arts Council (CAAC) is proud to present the 18th annual Rock Island Arts Festival (RIAF). Due to the growth of our event, we are requesting permission from the City of Chickasha and the City Council to utilize the area of Chickasha Avenue encompassing the Rock Island Depot area extending to Eighth Street.

The RIAF is to be held Friday and Saturday, October 2nd – October 3rd, 2026. Hours will be 10 am to 8 pm both days. The CAAC also requests to have access to the area beginning at 5:00 pm on Thursday, October 1st, to set up and decorate. We are asking for side streets (5th through 6th) to be blocked from alley to alley from 5:00 pm on October 1st through the 3rd. In addition, we tentatively request 7th street be blocked from alley to alley on Saturday, October 3rd, as well as Chickasha Avenue at 8th street. We are currently in negotiations with another group to add to the event to bring even more visitors to our area. We will, of course, coordinate with the funeral home directly as to not interfere with any services they may have should our negotiations prove fruitful.

We are asking permission to block access to Chickasha Avenue from Fourth Street going Westward to Seventh Street for the entirety of the event. In addition, we are requesting to block First Street to Fourth street on Saturday October 3rd to incorporate the Oklahoma Food Truck Championship (OFTC). We would like blockades to be in place by 5:00 pm on October 2nd to prevent access from 1st through 3rd streets on to Chickasha Avenue. Both the CAAC and the OFTC are committed to public safety during our combined event. With our combined resources, the RIAF and OFTC, joined by the Rock Island Ride and Together we Heal, make this weekend an event for everyone, promoting Chickasha and bringing awareness to all we have to offer as a community.

As the CAAC has demonstrated in previous years, we will make provisions to ensure that all details for insurance and security for this event are addressed.

Thank you for your consideration in permitting the CAAC and OFTC to hold this community event once again.

Sincerely,

Sue Getman

Sue Getman
Director RIAF 2026
CAAC Treasurer
(405) 274-7547
director@rockislandartsfestival.org

CHICKASHA

Meeting Type: Council Agenda 4-6-2026

Meeting Date: 4/6/2026

Department: City Clerk

Agenda Item No. 4.I.

AGENDA ITEM: Approve the Chickasha Area Arts Council Mini Festival set for June 6, 2026, and waive any associated fees.

I. BACKGROUND/DESCRIPTION:

II. RECOMMENDED ACTION:

Approve the Chickasha Area Arts Council Mini Festival set for June 6, 2026, and waive any associated fees.

III. FISCAL INFORMATION -

IV. FUND INFORMATION:

Dept. Director: Susan M.McDaniel, CMC City Clerk	Fund	Account	Amount
	(To)		
	FUND	ACCOUNT	AMOUNT
Meeting Date: April 6, 2026	(From)		

V. ATTACHMENTS:

- 20260401090252867



Chickasha Area Arts Council

Mailing Address – P.O. Box 505 – Chickasha, OK 73023
Physical Address – 521 W. Chickasha Avenue – Chickasha, OK 73018
www.chickashaarts.org 405-448-5036 chickashaarts@gmail.com
Federal Tax ID# 73-1385017

Executive Committee 2026

President
Erin Thompson
ebthompson04@gmail.com

Vice-President
Allison Cofer
allisoncofer1@gmail.com

Secretary
Susan Gearhart
susangearhart@gmail.com

Treasurer
Sue Getman
suegetman@msn.com

Board of Directors 2026

Freddy Baeza
Bryan Bramblett
Allison Cofer
Suzan Colvin
Debbie Fritter
Susan Gearhart
Sue Getman
Terry Godfrey
Adam Heilman
Amber Heilman
Angie Lewis
Sharon Storms
Erin Thompson

March 6, 2026

Chickasha City Council
Chickasha City Manager
117 N. 4th
Chickasha, OK 73018

RE: June 6th add on event

Dear Council,

The Chickasha Area Arts Council (CAAC) has been asked to hold a mini festival as an add-on to the 'Wings and Wheels' event at the airport. The idea behind the event is to try to encourage visitors already in the area to migrate to downtown after the big show at the airport. We will have a small amount of vendors, performers and concessions encompassing the area between the 500 and 600 blocks of Chickasha Ave. With that in mind, we would like to have permission to block the intersections of 5th and 6th streets and the entrance to Chickasha Ave at 7th street from 9 am through 9 pm on Saturday, June 6th. We will be encouraging all proprietors along Chickasha Avenue to open their doors, have sidewalk sales or outdoor vendors during the day as well.

Thank you for your consideration in permitting the CAAC to start, what we hope will turn into an annual, successful event.

Sincerely,

Sue Getman

Sue Getman
Director RIAF 2026
CAAC Treasurer
(405) 274-7547
director@rockislandartsfestival.org

CHICKASHA

Meeting Type: Council Agenda 4-6-2026

Meeting Date: 4/6/2026

Department: City Clerk

Agenda Item No. 4.m.

AGENDA ITEM: Approve Open Streets event scheduled for May 2, 2026, and waive any associated fees.

I. BACKGROUND/DESCRIPTION:

The Open Street Committee has requested to hold its annual Open Streets event on Saturday, May 2, 2026, from 10:00 a.m. to 2:00 p.m. in Downtown Chickasha. This event is free and open to the public. The purpose of this event is to encourage physical fitness in the community.

A Certificate of Liability Insurance has already been provided for the event.

II. RECOMMENDED ACTION:

Approve the request from the Open Streets Committee to hold its annual Open Streets event, closing Chickasha Avenue from the Rock Island Depot on 1st Street to 3rd Street on May 2, 2026, from 9:00 a.m. to 3:00 p.m. waiving all fees upon the executed required Indemnification Agreement.

III. FISCAL INFORMATION -

IV. FUND INFORMATION:

Dept. Director: Susam M. McDaniel, CMC City Clerk	Fund	Account	Amount
	(To)		
	FUND	ACCOUNT	AMOUNT
Meeting Date: April 6, 2026	(From)		

V. ATTACHMENTS:

- 20260401095014761



March 9, 2026

Honorable Mayor and City Council
City of Chickasha
117 N. 4th Street
Chickasha, Oklahoma 73018

Dear Honorable Mayor and Chickasha City Council,

On behalf of the Open Streets Committee, this request is to hold the 9th annual Open Streets Event on Saturday, May 2nd, 2025, from 10 am to 2 pm in Downtown Chickasha. This event would be free and open to the public. The purpose of the Open Streets Event is to encourage physical fitness in the community. We will be having vendors from the Chickasha community to promote different types of fitness (i.e., walking, jogging, bicycling, and more!).

The preparations for the event will take place beginning at 9am and be completed by 3 pm. We are requesting that permission be granted to host the event in Downtown Chickasha on Chickasha Avenue starting at N 3rd Street and extending through N 1st Street just past the Rock Island Depot. (Please refer to the sample Open Streets map included)

Please see the attached Certification of Insurance for the event.

Thank you for your time and for your support in our community activities.

Best regards,

Corbin Lee
E: cle@ymcaokc.org
P: 405-224-2281



CERTIFICATE OF LIABILITY INSURANCE

DATE (MM/DD/YYYY)
03/10/2026

THIS CERTIFICATE IS ISSUED AS A MATTER OF INFORMATION ONLY AND CONFERS NO RIGHTS UPON THE CERTIFICATE HOLDER. THIS CERTIFICATE DOES NOT AFFIRMATIVELY OR NEGATIVELY AMEND, EXTEND OR ALTER THE COVERAGE AFFORDED BY THE POLICIES BELOW. THIS CERTIFICATE OF INSURANCE DOES NOT CONSTITUTE A CONTRACT BETWEEN THE ISSUING INSURER(S), AUTHORIZED REPRESENTATIVE OR PRODUCER, AND THE CERTIFICATE HOLDER.

IMPORTANT: If the certificate holder is an ADDITIONAL INSURED, the policy(ies) must have ADDITIONAL INSURED provisions or be endorsed. If SUBROGATION IS WAIVED, subject to the terms and conditions of the policy, certain policies may require an endorsement. A statement on this certificate does not confer rights to the certificate holder in lieu of such endorsement(s).

PRODUCER Sterling Management Group 2901 NW 156th Street Edmond OK 73013	CONTACT NAME: Kathy Randall	PHONE (A/C, No, Ext): (405) 530-4019	FAX (A/C, No): (405) 530-4038
	E-MAIL ADDRESS: kathyrandall@lofiswetzel.com		
INSURED YMCA of Greater Oklahoma City 500 N Broadway Suite 500 Oklahoma City OK 73102-6298	INSURER(S) AFFORDING COVERAGE		NAIC #
	INSURER A: Crum & Forster Indemnity Co		
	INSURER B: Travelers		
	INSURER C:		
	INSURER D:		
	INSURER E:		
INSURER F:			

COVERAGES CERTIFICATE NUMBER: 25/26 Master REVISION NUMBER:

THIS IS TO CERTIFY THAT THE POLICIES OF INSURANCE LISTED BELOW HAVE BEEN ISSUED TO THE INSURED NAMED ABOVE FOR THE POLICY PERIOD INDICATED. NOTWITHSTANDING ANY REQUIREMENT, TERM OR CONDITION OF ANY CONTRACT OR OTHER DOCUMENT WITH RESPECT TO WHICH THIS CERTIFICATE MAY BE ISSUED OR MAY PERTAIN, THE INSURANCE AFFORDED BY THE POLICIES DESCRIBED HEREIN IS SUBJECT TO ALL THE TERMS, EXCLUSIONS AND CONDITIONS OF SUCH POLICIES. LIMITS SHOWN MAY HAVE BEEN REDUCED BY PAID CLAIMS.

INSR LTR	TYPE OF INSURANCE	ADDL INSD	SUBR WVD	POLICY NUMBER	POLICY EFF (MM/DD/YYYY)	POLICY EXP (MM/DD/YYYY)	LIMITS
A	COMMERCIAL GENERAL LIABILITY <input type="checkbox"/> CLAIMS-MADE <input checked="" type="checkbox"/> OCCUR <input checked="" type="checkbox"/> Owners & Contractors Protective <input checked="" type="checkbox"/> BI and PD deductible \$25,000 GEN'L AGGREGATE LIMIT APPLIES PER: <input checked="" type="checkbox"/> POLICY <input type="checkbox"/> PRO-JECT <input type="checkbox"/> LOC OTHER:	Y		506-919625-2	07/01/2025	07/01/2026	EACH OCCURRENCE \$ 1,000,000 DAMAGE TO RENTED PREMISES (Ea occurrence) \$ 1,000,000 MED EXP (Any one person) \$ 10,000 PERSONAL & ADV INJURY \$ 1,000,000 GENERAL AGGREGATE \$ 2,000,000 PRODUCTS - COMP/OP AGG \$ 1,000,000 Employee Benefits \$ 1,000,000
A	AUTOMOBILE LIABILITY <input type="checkbox"/> ANY AUTO <input type="checkbox"/> OWNED AUTOS ONLY <input checked="" type="checkbox"/> SCHEDULED AUTOS <input checked="" type="checkbox"/> HIRED AUTOS ONLY <input checked="" type="checkbox"/> NON-OWNED AUTOS ONLY			506-919625-2	07/01/2025	07/01/2026	COMBINED SINGLE LIMIT (Ea accident) \$ 1,000,000 BODILY INJURY (Per person) \$ BODILY INJURY (Per accident) \$ PROPERTY DAMAGE (Per accident) \$ Uninsured motorist \$ 1,000,000
A	UMBRELLA LIAB <input checked="" type="checkbox"/> OCCUR EXCESS LIAB <input type="checkbox"/> CLAIMS-MADE DED RETENTION \$			582-13100-4	07/01/2025	07/01/2026	EACH OCCURRENCE \$ 1,000,000 AGGREGATE \$ 1,000,000
	WORKERS COMPENSATION AND EMPLOYERS' LIABILITY ANY PROPRIETOR/PARTNER/EXECUTIVE OFFICER/MEMBER EXCLUDED? (Mandatory in NH) <input type="checkbox"/> Y <input checked="" type="checkbox"/> N If yes, describe under DESCRIPTION OF OPERATIONS below		N/A				PER STATUTE OTH-ER E.L. EACH ACCIDENT \$ E.L. DISEASE - EA EMPLOYEE \$ E.L. DISEASE - POLICY LIMIT \$
B	Business Personal Property Special Form, Agreed Value			KTK-CMB-7T59961-4-25	07/01/2025	07/01/2026	Limit 755,000 All Other Peril Deductible 100,000 Wind/Hail Deductible 3% min 250,000

DESCRIPTION OF OPERATIONS / LOCATIONS / VEHICLES (ACORD 101, Additional Remarks Schedule, may be attached if more space is required)

Cert holder shall be an additional insured in accordance with all the terms, conditions & limitations of the policy & then only with respect to liability caused by the negligent acts or omissions of the Named Insured
Open Streets events 2026
located Chickasha Ave between 3rd and 1st streets.

CERTIFICATE HOLDER

CANCELLATION

City of Chickasha 117 N. 4th Street Chickasha OK 73018	SHOULD ANY OF THE ABOVE DESCRIBED POLICIES BE CANCELLED BEFORE THE EXPIRATION DATE THEREOF, NOTICE WILL BE DELIVERED IN ACCORDANCE WITH THE POLICY PROVISIONS. AUTHORIZED REPRESENTATIVE 
------------------------------------------------------------------	------------------------------------------------------------------------------------------------------------------------------------------------------------------------------------------------------------------------------------------------------------------------------------------

© 1988-2015 ACORD CORPORATION. All rights reserved.



1. Chickasha Community Theatre
2. Grady County Sheriff
3. USAO
4. TOPS (Taking Pounds Off)
5. USAO Art Dept
6. Water Slide
7. Cricket Wireless
8. Water Slide
9. Focus Federal Credit Union
10. International Altrusa of Chickasha
11. Inflatable
12. TSET Healthy Living Program
13. Ben & Jays
14. Southwestern Oklahoma Development Authority
15. Popworth's Kettlecorn LLC
16. KOOL 105.5
17. Rick Johnston State Farm Insurance

18. Chickasha Area YMCA
19. ARVEST BANK
20. Grady County 4-H
21. Century 21 Mosley
22. Humana
23. Air Force
24. Canadian River Brewery
25. Oh18
26. Flowershop & Winery
27. Chickasha Kiwanis Club
28. Jungle Ice
29. Chickasha Fire Department
30. Chickasha Area Arts Council
31. Standley Systems, LLC
32. Steel Monkey Gym
33. Oklahoma Fosters
34. Alpacas of Oklahoma
35. Upside Down Artist

This community event is made possible by our generous sponsors.

Performances/Demonstrations
 (Intersection of 2nd & Chickasha Ave)

11:00-11:30 – Grand Spirit Squad

Information and Raffle Entry at the Chickasha Area YMCA booth.



CHICKASHA

Meeting Type: Council Agenda 4-6-2026

Meeting Date: 4/6/2026

Department: Finance

Agenda Item No. 6.a.

AGENDA ITEM: Discussion, consideration, and possible action to accept the Financial Audit for the Fiscal Year Ending June 30, 2024.

I. BACKGROUND/DESCRIPTION:

Presentation of the audit reports for Fiscal Year Ending June 30, 2024. Andy Cromer, Director of HSPG & Associates, will be providing the presentation. A vote is required for acceptance of the reports.

II. RECOMMENDED ACTION:

Accept and ratify the Financial Audit for the Fiscal Year Ending June 30, 2024.

III. FISCAL INFORMATION -

IV. FUND INFORMATION:

Dept. Director: Rich Edwards, Finance Director	Fund	Account	Amount
	(To)		
	FUND	ACCOUNT	AMOUNT
Meeting Date: April 6, 2026	(From)		

V. ATTACHMENTS:

- 20260401103437227

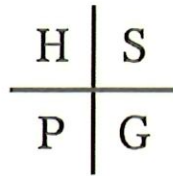

INDEPENDENT AUDITOR'S REPORT

To the Honorable Mayor and Members of the City Council
City of Chickasha, Oklahoma

Report on the Audit of the Financial Statements

Opinions

We have audited the accompanying modified cash basis financial statements of the governmental activities, the business-type activities, each major fund, and aggregate remaining fund information of the City of Chickasha, Oklahoma (the "City") as of and for the year ended June 30, 2024, and the related notes to the financial statements, which collectively comprise the City's basic financial statements as listed in the table of contents.

In our opinion, the financial statements referred to above present fairly, in all material respects, the respective modified cash basis financial position of the governmental activities, the business-type activities, each major fund, and the aggregate remaining fund information of the City as of June 30, 2024, and the respective changes in modified cash basis financial position, and where applicable, cash flows thereof for the year then ended in accordance with the modified cash basis of accounting described in Note 1.

Basis for Opinions

We conducted our audit in accordance with auditing standards generally accepted in the United States of America and the standards applicable to financial audits contained in *Government Auditing Standards*, issued by the Comptroller General of the United States. Our responsibilities under those standards are further described in the Auditor's Responsibilities for the Audit of the Financial Statements section of our report. We are required to be independent of the City and to meet our other ethical responsibilities in accordance with the relevant ethical requirements relating to our audit. We believe that the audit evidence we have obtained is sufficient and appropriate to provide a basis for our audit opinions.

Emphasis of Matter—Basis of Accounting

We draw attention to Note 1 of the financial statements, which describes the basis of accounting. The financial statements are prepared on the modified cash basis of accounting, which is a basis of accounting other than accounting principles generally accepted in the United States of America. Our opinions are not modified with respect to this matter.

Responsibilities of Management for the Financial Statements

Management is responsible for the preparation and fair presentation of these financial statements in accordance with the modified cash basis of accounting described in Note 1, and for determining that the modified cash basis of accounting is an acceptable basis for the preparation of the financial statements in the circumstances. Management is also responsible for the design, implementation, and maintenance of internal control relevant to the preparation and fair presentation of financial statements that are free from material misstatement, whether due to fraud or error.

HSPG & ASSOCIATES, PC

5400 N Grand Blvd, Suite 330 • Oklahoma City, Oklahoma 73112 • Phone: 405.844.9995 • Fax: 405.844.9975

Auditor's Responsibilities for the Audit of the Financial Statements

Our objectives are to obtain reasonable assurance about whether the financial statements as a whole are free from material misstatement, whether due to fraud or error, and to issue an auditor's report that includes our opinions. Reasonable assurance is a high level of assurance but is not absolute assurance and therefore is not a guarantee that an audit conducted in accordance with generally accepted auditing standards and *Government Auditing Standards* will always detect a material misstatement when it exists. The risk of not detecting a material misstatement resulting from fraud is higher than for one resulting from error, as fraud may involve collusion, forgery, intentional omissions, misrepresentations, or the override of internal control. Misstatements are considered material if there is a substantial likelihood that, individually or in the aggregate, they would influence the judgment made by a reasonable user based on the financial statements.

In performing an audit in accordance with generally accepted auditing standards and *Government Auditing Standards*, we:

- Exercise professional judgment and maintain professional skepticism throughout the audit.
- Identify and assess the risks of material misstatement of the financial statements, whether due to fraud or error, and design and perform audit procedures responsive to those risks. Such procedures include examining, on a test basis, evidence regarding the amounts and disclosures in the financial statements.
- Obtain an understanding of internal control relevant to the audit in order to design audit procedures that are appropriate in the circumstances, but not for the purpose of expressing an opinion on the effectiveness of the City's internal control. Accordingly, no such opinion is expressed.
- Evaluate the appropriateness of accounting policies used and the reasonableness of significant accounting estimates made by management, as well as evaluate the overall presentation of the financial statements.
- Conclude whether, in our judgment, there are conditions or events, considered in the aggregate, that raise substantial doubt about the City's ability to continue as a going concern for a reasonable period of time.

We are required to communicate with those charged with governance regarding, among other matters, the planned scope and timing of the audit, significant audit findings, and certain internal control-related matters that we identified during the audit.

Other Matters

Supplemental Information

Our audit was conducted for the purpose of forming opinions on the financial statements that collectively comprise the City's basic financial statements. The accompanying supplemental combining schedules – modified cash basis, as listed in the table of contents, are presented for purposes of additional analysis and are not a required part of the basic financial statements.

Such information is the responsibility of management and was derived from and relates directly to the underlying accounting and other records used to prepare the basic financial statements. The information has been subjected to the auditing procedures applied in the audit of the basic financial statements and certain additional procedures, including comparing and reconciling such information directly to the underlying accounting and other records used to prepare the basic financial statements or to the basic financial statements themselves, and other additional procedures in accordance with auditing standards generally accepted in the United States of America.

In our opinion, the combining schedules are fairly stated, in all material respects, in relation to the basic financial statements as a whole.

Other Information

Management is responsible for the other information included in the annual report. The other information comprises the management's discussion and analysis and budgetary comparison information but does not include the basic financial statements and our auditor's report thereon. Our opinions on the basic financial statements do not cover the other information, and we do not express an opinion or any form of assurance thereon.

In connection with our audit of the basic financial statements, our responsibility is to read the other information and consider whether a material inconsistency exists between the other information and the basic financial statements, or the other information otherwise appears to be materially misstated. If, based on the work performed, we conclude that an uncorrected material misstatement of the other information exists, we are required to describe it in our report.

Other Reporting Required by *Government Auditing Standards*

In accordance with *Government Auditing Standards*, we have also issued our report dated March 27, 2026, on our consideration of the City's internal control over financial reporting and our tests of its compliance with certain provisions of laws, regulations, contracts and grant agreements and other matters. The purpose of that report is solely to describe the scope of our testing of internal control over financial reporting and compliance and the results of that testing, and not to provide an opinion on the effectiveness of the City's internal control over financial reporting or on compliance. That report is an integral part of an audit performed in accordance with *Government Auditing Standards* in considering the City's internal control over financial reporting and compliance.

HSPG & Associates, P.C.

March 27, 2026

CHICKASHA

Meeting Type: Council Agenda 4-6-2026

Meeting Date: 4/6/2026

Department: Community Development

Agenda Item No. 6.b.

AGENDA ITEM: Public Hearing to discuss and consider the Rezoning for 512 S 18th from R-1 to R-3 for applicant Nicole Myers.

I. BACKGROUND/DESCRIPTION:

This rezone was passed by planning commission on 3/10/2026
this is to rezone R-1 Single Family to R-3 multi-family

II. RECOMMENDED ACTION:

Recommend approval

III. FISCAL INFORMATION -

IV. FUND INFORMATION:

Dept. Director: Jessica Green, Community Development Director	Fund	Account	Amount
	(To)		
	FUND	ACCOUNT	AMOUNT
Meeting Date: 4/6/2026	(From)		

V. ATTACHMENTS:

- 20260311084041911



REZONING APPLICATION

APPLICANT INFORMATION

Name Nicole Myers		Date 11/12/2025
Address 370 County Road 1360		Email: Nickelnm.iglide@gmail.com
City, State, and Zip Code Chickasha, OK 73018		Phone Numbers 405-274-0595
Applicant's Signature <i>Nicole Myers</i>		

- Deed attached (required). If applicant is not the owner listed on the deed, then written owner consent must be included
- Property ownership list attached (required)

PROPERTY LOCATION

<input checked="" type="checkbox"/> Platted <input type="checkbox"/> Unplatted	Subdivision West Hill Addn	Lot 1	Block 4
Property Address 512 S 18th Street Chickasha, OK 73018			
Legal Description (if unplatted). You may attach the legal description to this application. 29-07-07-10300 N 115' Lot 1 Block 4 West Hill Addn			

REZONING INFORMATION

From R-1	To R-3	Land Use Designation	
Present Use Single Family Residence		Proposed Use Multi Family Residential / Mixed Use	
Parcel Width	Parcel Length	Acres 0.25	Street/Road Frontage
Please explain why this property should be rezoned. Your response may be attached to this application, along with any additional supporting information. See Attached Letter			

The following is a checklist of all other requirements of the application:

- A letter requesting the re-zoning and reasons why the re-zoning is being sought.
- An Abstractor's Certified Property Owners list of property owners within 300' of subject property.
- All Materials are due no later than the date set by the Community Development Director, as noted on this Application.**

ALL INFORMATION ON THIS FORM MUST BE COMPLETED IN ORDER TO PROCESS YOUR REQUEST

To Whom it May Concern,

I am formally requesting the re-zoning of 512 S 18th Street Chickasha, OK 73018 from its current zoning of R1 to multi-family residential/mixed use. I further request that the city road to the West of the (between the above listed address and the train tracks) property be closed between the above listed address and the train tracks.

The request for the re-zoning request comes as a result of the following reasons:

- The intent is to build a multi-family residence upon a large corner lot.
- The addition of such a residence and re-zoning would lead to much needed increase in affordable housing.
- Re-zoning allows a single lot to house multiple families and aid the community's needs.
- Historically, my renters stay a minimum of 5 years; this equates to stabilized housing for our community.
- I consistently, and intentionally, keep my rent below market rents in an effort to supply affordable rental housing for the community.
- I own all of Lot 1; re-zoning would not impact any other owners in the area as the only touching land is owned by myself.

The request for road closure is derived from the following reasons:

- The road is not currently and has not been since my purchase of this property, maintained by the city.
- Closure of the road would release the city of necessary funding to maintain/repair the mentioned road; this funding could be better used to fund other projects whether they be roads that are travelled, or projects that need additional funding.
- When speaking to City of Chickasha representatives, the existence of the road is not known to them, and it lacks any street signs though there is a City owned stop sign hidden by a tree. I have had to explain its location and/or point the road out to representatives. Maintaining such a road, and the necessary repair work to bring said road up to standards, would be an undue hardship on the City of Chickasha.

Elzie Leon & Hilda Shelton
C/O Sandra Nix
18151 Lora Lea Lane
Norman, Oklahoma 73026

Stephen & Elsie B. Kande
8848 Sailfish Bay Circle
Sacramento, Ca 95826

Joshua W. & Ashley A. Grady
1714 W. Minnesota Ave
Chickasha, Ok 73018

BCP, LLC
602 S 4th Street
Chickasha, Ok 73018

Marcia A. Baker
1814 Dakota Avenue
Chickasha, Oklahoma 73018

Greg & Brian White
2455 County Street 2870
Chickasha, Ok 73018

Carl C. & Shirley Ann Smith
2670 County Steet 2790
Chickasha, Oklahoma 73018

Mercell Jean & Robert Lloyd Gorrell
1712 W. Dakota
Chickasha, Oklahoma 73018

Carolyn Ruth & John E. Young
1720 Dakota Ave
Chickasha, Oklahoma 73018

Denver Talley Properties, Inc
1326 S 20th Street
Chickasha, Oklahoma 73018

Bonita & Jason Harrison
35 McKenzie Drive
Chickasha, Oklahoma 73018

Kevin Crawford
516 S 18th Street
Chickasha, Oklahoma 73018

Connie & Ronnie Webster
1717 W. Minnesota
Chickasha, Oklahoma 73018

Susan Garten
1727 W. Minnesota
Chickasha, Ok 73018

Alice Sue Thomas
1713 Minnesota Ave
Chickasha, Oklahoma 73018

Jimmy Pool
511 S 18th Street
Chickasha, Oklahoma 73018

Chickasha Properties, LLC
C/O Kenneth A. Dennison
P.O. Box 57
Green Cove Springs, Florida 32043

Richard L. Wilson
1822 W. Minnesota
Chickasha, Oklahoma 73018

Marcia A. Baker
1814 Dakota Ave
Chickasha, Oklahoma 73018

Jody Farley
1824 Minnesota Avenue
Chickasha, Oklahoma 73018

William C. & Linda A. Miller
1826 Minnesota Ave
Chickasha, Oklahoma 73018

Royalty Management, LLC
PO Box 2100
Chickasha, Ok 73023

Tammie Wilkins & Dee Ella Lackey
6115 N County Line Road
Blanchard, Ok 73010

STATE OF OKLAHOMA

SS

COUNTY OF GRADY

The undersigned lawfully Bonded Abstracters in and for said County and State, do hereby certify that the foregoing attached sheets contain a true and complete take-off of the names and addresses of the taxpayers of the real property opposite their names, according to the records in the office of the County Treasurer and County Assessor of Grady County, Oklahoma, for the calendar year of 2024.

The Abstracter does not pass on the validity or sufficiency of any instrument of record, nor the marketability of the title; nor do we assume any liability in the excess of \$300.00 in furnishing this report. Dated at Chickasha, Grady County, Oklahoma, this 6th day of November, 2025 @ 7:59 A.M.

WASHITA VALLEY ABSTRACT & TITLE, LLC

By

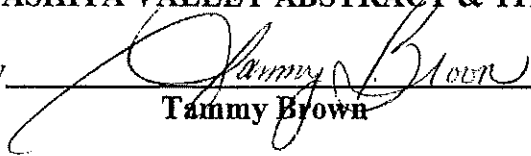

Tammy Brown

**SPECIAL CERTIFICATE
158843**

RE:

The North 115 feet of Lot 1 in Block 4 in West Hill Addition to the City of Chickasha, Grady County, Oklahoma, according to the recorded plat thereof.

THE FOLLOWING IS A LIST OF PROPERTY OWNERS WITHIN 300 FEET OF THE ABOVE DESCRIBED PROPERTY:

Owner:

**Elzie Leon & Hilda Shelton
c/o Sandra Nix
18151 Lora Lea Lane
Norman, OK 73026**

Description:

The East 25 feet of Lot 4 and the West 25 feet of Lot 5 Block 3 in West Hill Addition to the City of Chickasha, Grady County, Oklahoma, according to the recorded plat thereof.

Owner:

**Stephen & Elsie B. Kande
8848 Sailfish Bay Circle
Sacramento, CA 95826-6436**

Description:

The East 61 feet of the West 126 feet of Lot 4 Block 3 in West Hill Addition to the City of Chickasha, Grady County, Oklahoma, according to the recorded plat thereof.

Owner:

**Joshua W. & Ashley A. Grady
1714 W. Minnesota Avenue
Chickasha, OK 73018**

Description:

The East 25 feet of Lot 5; All Lot 6 Block 3 in West Hill Addition to the City of Chickasha, Grady County, Oklahoma, according to the recorded plat thereof.

Owner:

**BCP, LLC
602 S. 4th Street
Chickasha, OK 73018**

Description:

The West 65 feet of Lot 4 in Block 3 in West Hill Addition to the City of Chickasha, Grady County, Oklahoma, according to the recorded plat thereof.

Description:

Lot 7 and the W/2 of Lot 8 in Block 3 in West Hill Addition to the City of Chickasha, Grady County, Oklahoma, according to the recorded plat thereof.

Owner:

**Marcia A. Baker
1814 Dakota Avenue
Chickasha, OK 73018**

Description:

Lot 3 and the West 23 feet of the South 115 feet of Lot 4 in Block 4 in West Hill Addition to the City of Chickasha, Grady County, Oklahoma, according to the recorded plat thereof.

Owner:

**Greg & Brian White
2455 County Street 2870
Chickasha, OK 73018**

Description:

Lot 11 Block 5 in West Hill Addition to the City of Chickasha, Grady County, Oklahoma, according to the recorded plat thereof.

Owner:

**Carl C. & Shirley Ann Smith
2670 County Street 2790
Chickasha, OK 73018**

Description:

The South 115 feet of the East 25 feet in Lot 5 and the South 115 feet of Lot 6 Block 4 in West Hill Addition to the City of Chickasha, Grady County, Oklahoma, according to the recorded plat thereof.

The East 27 feet of the South 115 feet of Lot 4 and the South 115 feet of the W/2 of Lot 5 Block 4 in West Hill Addition to the City of Chickasha, Grady County, Oklahoma, according to the recorded plat thereof.

Owner:

**Mercell Jean & Robert Lloyd Gorrell
1712 W. Dakota Avenue
Chickasha, OK 73018**

Description:

Lot 12 Block 5 in West Hill Addition to the City of Chickasha, Grady County, Oklahoma, according to the recorded plat thereof.

Owner:

**Carolyn Ruth & John E. Young
1720 Dakota Avenue
Chickasha, OK 73018**

Description:

Lot 10 Block 5 in West Hill Addition to the City of Chickasha, Grady County, Oklahoma, according to the recorded plat thereof.

Owner:

**Denver Talley Properties, Inc.
1326 S 20th Street
Chickasha, OK 73018**

Description:

Lot 8 Block 5 in West Hill Addition to the City of Chickasha, Grady County, Oklahoma, according to the recorded plat thereof.

Owner:

**Bonita & Jason Harrison
35 McKenzie Drive
Chickasha, OK 73018**

Description:

Lot 3 Block 5 in West Hill Addition to the City of Chickasha, Grady County, Oklahoma, according to the recorded plat thereof.

Owner:

**Kevin Crawford
516 S. 18th Street
Chickasha, OK 73018**

Description:

The North 50 feet of Lot 5 & 6 in Block 4 in West Hill Addition to the City of Chickasha, Grady County, Oklahoma, according to the recorded plat thereof.

Owner:

**Connie & Rodney Webster
1717 W. Minnesota Avenue
Chickasha, OK 73018**

Description:

Lot 5 Block 5 in West Hill Addition to the City of Chickasha, Grady County, Oklahoma, according to the recorded plat thereof.

Owner:

Owner:
Susan Garten
1727 W. Minnesota Avenue
Chickasha, OK 73018

Description:
The North 107 feet of Lot 7 in Block 5 in West Hill Addition to the City of Chickasha, Grady County, Oklahoma, according to the recorded plat thereof.

Owner:
Alice Sue Thomas
1713 Minnesota Avenue
Chickasha, OK 73018

Description:
Lot 4 Block 5 in West Hill Addition to the City of Chickasha, Grady County, Oklahoma, according to the recorded plat thereof.

Owner:
Jimmy Pool
511 S 18th Street
Chickasha, OK 73018

Description:
The South 58 feet of Lot 7 in Block 5 in West Hill Addition to the City of Chickasha, Grady County, Oklahoma, according to the recorded plat thereof.

Owner:
Chickasha Properties, LLC
c/o Kenneth A. Dennison
PO Box 57
Green Cove Springs, FL 32043

Description:
Lot 12 Block 19 in Phillips Addition to the City of Chickasha, Grady County, Oklahoma, according to the recorded plat thereof.

Owner:
Richard L. Wilson
1822 W. Minnesota
Chickasha, OK 73018

Description:
Lot 16 Block 19 in Phillips Addition to the City of Chickasha, Grady County, Oklahoma, according to the recorded plat thereof.

Owner:
Marcia A. Baker
1814 Dakota Avenue
Chickasha, OK 73018

Description:
The North 50 feet of Lot 4 in Block 4 in West Hill Addition to the City of Chickasha, Grady County, Oklahoma, according to the recorded plat thereof.

Owner:
Jody Farley
1824 Minnesota Avenue
Chickasha, OK 73018

Description:
Lot 16 in Block 19 in Phillips Addition to the City of Chickasha, Grady County, Oklahoma, according to the recorded plat thereof.

Owner:
William C. & Linda A. Miller
1826 Minnesota Avenue
Chickasha, OK 73018

Description:
Lot 13 and the West 12 feet of Lot 14 in Block 19 in Phillips Addition to the City of Chickasha, Grady County, Oklahoma, according to the recorded plat thereof.

Owner:
Royalty Management, LLC
PO Box 2100
Chickasha, OK 73023

Description:
Lots 1 thru 4 in Block 19 in Phillips Addition to the City of Chickasha, Grady County, Oklahoma, according to the recorded plat thereof.

Owner:
Tammie Wilkins & Dee Ella Lackey
6115 N County Line Road
Blanchard, OK 73010

Description:
Lot 20 in Block 18 in Phillips Addition to the City of Chickasha, Grady County, Oklahoma, according to the recorded plat thereof.

CHICKASHA

COMMUNITY DEVELOPMENT

**NOTICE OF PUBLIC
HEARING PC PETITION
REQUEST FOR A REZONING FROM R-1 TO R-3**

NOTICE IS HEREBY GIVEN, that the City of Chickasha Planning Commission will hold a public hearing beginning at 4:00 p.m. on Tuesday, March 10th, 2026, at Chickasha City Hall, 117 North 4th Street, Chickasha, Oklahoma. This public hearing is regarding the petition by Nicole Myers requesting a rezone on a lot from R-1 to R-3 on the following described property:

512 S 18th - 29-07-07-10300 N 115' LOT 1 BLK 4 WEST HILL ADDN

BRIEF DESCRIPTION OF REQUEST: The applicant wishes to rezone this lot in order to add onto the existing dwelling to make a duplex, or multi-family unit.



Any person supporting or having any objections to this petition may appear before the Planning Commission on the above date set for hearing and show cause why the petition should or should not be approved. Written comments regarding this petition should be emailed to jessica.green@chickasha.org or be mailed to City of Chickasha, Community Development Department, 117 North 4th street Chickasha, Ok 73018.

Please call the Community Development Department at 405-222-6010 or email jessica.green@chickasha.org should you have any questions regarding this petition.

There will also be a public hearing on this petition at the April 6th, 2026, City Council meeting at Chickasha City Hall, 117 North 4th Street, Chickasha Oklahoma.

Sincerely,



Jessica Green,
Community Development Director

PROOF OF PUBLICATION

In the District Court of Grady County, State of Oklahoma

512 S. 18TH

Affidavit of Publication

State of Oklahoma, County of Grady, ss:

I, the undersigned publisher, editor or Authorized Agent of the Chickasha Daily Express, do solemnly swear that the attached advertisement was published in said paper as follows:

02/19/2026

That said newspaper is Weekly, in the city of Chickasha, Grady County, Oklahoma, a Weekly newspaper qualified to publish legal notices, advertisements and publications as provided in Section 106 of Title 25, Oklahoma Statutes 1971, as amended, and complies with all other requirements of the laws of Oklahoma with reference to legal publications.

That said Notice, a true copy of which is attached hereto, was published in the regular edition of said newspaper during the period and time of publications and not in a supplement, on the above noted dates.

Signature

Subscribed and sworn before me on this 19th day of February, 2026

Katherine Miller, Notary Public
My commission expires 07/26/2028
Commission # 24009395



Cost of Publication \$ 56.70

Ad # 167879 Acct # 44095 Copies: 1

PAY TO:
The Express Star
PO Drawer E
Chickasha, OK 73023

Published In
The Express-Star
February 19, 2026
1 time
LPXLP
NOTICE OF PUBLIC HEARING
PC PETITION
REQUEST FOR A REZONING
FROM R-1 TO R-3
NOTICE IS HEREBY GIVEN, that the City of Chickasha Planning Commission will hold a public hearing beginning at 4:00 p.m. on Tuesday, March 10th, 2026, at Chickasha City Hall, 117 North 4th Street, Chickasha, Oklahoma. This public hearing is regarding the petition by Nicole Myers requesting a rezone on a lot from R-1 to R-3 on the following described property: 512 S 18th - 29-07-07-10300 N 115' LOT 1 BLK 4 WEST HILL ADDN
BRIEF DESCRIPTION OF REQUEST: The applicant wishes to rezone this lot in order to add onto the existing dwelling to make a duplex, or multi-family unit. Any person supporting or having any objections to this petition may appear before the Planning Commission on the above date set for hearing and show cause why the petition should or should not be approved. Written comments regarding this petition should be emailed to jessica.green@chickasha.org or be mailed to City of Chickasha, Community Development Department, 117 North 4th street Chickasha, Ok 73018. Please call the Community Development Department at 405-222-6010 or email jessica.green@chickasha.org should you have any questions regarding this petition. There will also be a public hearing on this petition at the April 6th, 2026, City Council meeting at Chickasha City Hall, 117 North 4th Street, Chickasha Oklahoma.
Sincerely,
Jessica Green,
Community Development Director

CHICKASHA

Meeting Type: Council Agenda 4-6-2026

Meeting Date: 4/6/2026

Department: Community Development

Agenda Item No. 6.c.

AGENDA ITEM: Discussion, consideration, and possible action to approve Ordinance 2026-07 rezoning request for 512 S 18th for applicant Nicole Myers from R-1 to R-3.

I. BACKGROUND/DESCRIPTION:

This rezone was passed by planning commission on 3/10/2026
this is to rezone R-1 Single Family to R-3 multi-family

II. RECOMMENDED ACTION:

Approve Ordinance 2026-07 as presented.

III. FISCAL INFORMATION -

IV. FUND INFORMATION:

Dept. Director: Jessica Green, Community Development Director	Fund	Account	Amount
	(To)		
	FUND	ACCOUNT	AMOUNT
Meeting Date: 4/6/2026	(From)		

V. ATTACHMENTS:

1. Ord. 2026-07 512 S. 18th Zoning Change

ORDINANCE NO. 2026-07

AN ORDINANCE OF THE MAYOR AND COUNCIL OF THE CITY OF CHICKASHA, GRADY COUNTY, STATE OF OKLAHOMA, AMENDING THE ZONING MAP AND ZONING ORDINANCES BY CHANGING THE ZONING DISTRICT FOR REAL PROPERTY LOCATED AT 512 S 18th CHICKASHA, OKLAHOMA, FROM R-1 SINGLE-FAMILY RESIDENTIAL DISTRICT TO R-3: MULTI-FAMILY RESIDENTIAL DISTRICT; PROVIDING FOR REPEALER; PROVIDING FOR SEVERABILITY; AND ESTABLISHING AN EFFECTIVE DATE.

WHEREAS, the City of Chickasha has adopted zoning regulations pursuant to Title 11 of the Oklahoma Statutes §§ 43-101 et seq. and Chapter 54 of the Chickasha Code of Ordinances including Section 54-187; and

WHEREAS, Section 54-187 requires that all applications for zoning amendments include a certified abstractor produced list of all property owners within a 300 foot radius of the exterior boundary lines of the property proposed to be rezoned and requires that mailed notice be provided to all such property owners at least twenty 20 days prior to the Planning Commission hearing; and

WHEREAS, the applicant provided the required certified abstractor produced list identifying all property owners within the 300 foot notification radius and the City caused mailed notice to be sent to all owners listed therein at least twenty 20 days prior to the Planning Commission hearing; and

WHEREAS, in accordance with Section 54-187 and 11 O.S. § 43-104 public notice of the Planning Commission and City Council hearings was published at least fifteen 15 days prior to the hearing in a newspaper of general circulation in the City; and

WHEREAS, the Planning Commission held a duly noticed public hearing on March 10, 2026 at which all interested persons including nearby property owners were afforded an opportunity to be heard and the Planning Commission thereafter voted to recommend approval of the zoning amendment; and

WHEREAS, the City Council thereafter conducted its own properly noticed public hearing in accordance with Oklahoma law and Section 54-187 and finds that the requested zoning amendment is appropriately compatible with surrounding uses consistent with the City's Comprehensive Plan and promotes the public health safety and welfare;

NOW THEREFORE BE IT ORDAINED BY THE MAYOR AND COUNCIL OF THE CITY OF CHICKASHA STATE OF OKLAHOMA:

SECTION 1. The zoning map and zoning ordinances of the City of Chickasha are hereby amended by changing the zoning district classification of the following described real property from R-1 Single-Family Residential District to R-3: Multi-Family Residential District, to wit:

The North 115 feet of Lot 1 Block 4 in West Hill Addition to the City of Chickasha, Grady County, Oklahoma, according to the recorded plat thereof.

Commonly known as 512 S 18th Chickasha, Oklahoma.

SECTION 2. Repealer. All ordinances or parts thereof which are inconsistent with this ordinance are repealed upon the effective date of this ordinance.

SECTION 3. Severability. If any section subsection sentence clause phrase or portion of this ordinance is held invalid or unconstitutional such portion shall be deemed a separate independent provision and shall not affect the validity of the remaining portions.

SECTION 4. Effective Date and Publication. This ordinance shall take effect thirty 30 days after its passage approval and publication as required by law.

Adopted and approved this 6th day of April 2026.

Zachary Grayson, Mayor

ATTESTED:

Susan M. McDaniel, CMC - City Clerk (SEAL)

CHICKASHA

Meeting Type: Council Agenda 4-6-2026

Meeting Date: 4/6/2026

Department: Community Development

Agenda Item No. 6.d.

AGENDA ITEM: Public Hearing to discuss and consider the Rezoning for 624 N 10th from R-1 to R-2 for applicant Brandon Smith.

I. BACKGROUND/DESCRIPTION:

II. RECOMMENDED ACTION:

III. FISCAL INFORMATION -

IV. FUND INFORMATION:

Dept. Director:	Fund	Account	Amount
Jessica Green, Community Development Director	(To)		
	FUND	ACCOUNT	AMOUNT
Meeting Date: April 6, 2026	(From)		

V. ATTACHMENTS:

1. 20260311131337542



REZONING APPLICATION

APPLICANT INFORMATION

Name <i>Brandon Smith</i>		Date <i>1/21/26</i>
Address <i>601 S. 8th St</i>		Email: <i>btsmith92@yahoo.com</i>
City, State, and Zip Code <i>Yukon Oklahoma 73099</i>		Phone Numbers <i>405-535-2048</i>
Applicant's Signature <i>[Signature]</i>		

- Deed attached (required). If applicant is not the owner listed on the deed, then written owner consent must be included
- Property ownership list attached (required)

PROPERTY LOCATION

<input type="checkbox"/> Platted	Subdivision	Lot	Block
<input checked="" type="checkbox"/> Unplatted	<i>Lot 5 and 6 in block 95</i>	<i>5 and 6</i>	<i>95</i>
Property Address <i>620 N. 10th, 624 N. 10th Chickasha OK, 73018</i>			
Legal Description (if unplatted). You may attach the legal description to this application. <i>See attached</i>			

REZONING INFORMATION

From <i>R1</i>	To <i>R2</i>	Land Use Designation <i>Duplex's</i>	
Present Use <i>Single Family</i>		Proposed Use <i>Two Family</i>	
Parcel Width	Parcel Length	Acres	Street/Road Frontage <i>N. 10th</i>
Please explain why this property should be rezoned. Your response may be attached to this application, along with any additional supporting information. <i>See attached letter</i>			

The following is a checklist of all other requirements of the application:

- A letter requesting the re-zoning and reasons why the re-zoning is being sought.
- An Abstractor's Certified Property Owners list of property owners within 300' of subject property.
- All Materials are due no later than the date set by the Community Development Director, as noted on this Application.**

ALL INFORMATION ON THIS FORM MUST BE COMPLETED IN ORDER TO PROCESS YOUR REQUEST

T. Brandon Smith want to Rezone
620, 624 Nth 10th from R1 to R2
to build duplex's

CHICKASHA

COMMUNITY DEVELOPMENT

NOTICE OF PUBLIC
HEARING PC PETITION
REQUEST FOR A REZONING FROM R-1 TO R-2

NOTICE IS HEREBY GIVEN, that the City of Chickasha Planning Commission will hold a public hearing beginning at 4:00 p.m. on Tuesday, March 10th, 2026, at Chickasha City Hall, 117 North 4th Street., Chickasha, Oklahoma. This public hearing is regarding the petition by Brandon Smith requesting a rezone on 2 lots from R-1 to R-2 on the following described properties:

**620 N 10th - 28-07-07-54600 ALL LOT 5 & S 25'
LOT 6 BLK 95 CHICKASHA-OT**

**624 N 10th - 28-07-07-54650 N 75' LOT 6 BLK 95
CHICKASHA-OT**

BRIEF DESCRIPTION OF REQUEST: The applicant wishes to rezone these lots in order to build duplexes on them.



Any person supporting or having any objections to this petition may appear before the Planning Commission on the above date set for hearing and show cause why the petition should or should not be approved. Written comments regarding this petition should be emailed to jessica.green@chickasha.org or be mailed to City of Chickasha, Community Development Department, 117 North 4th street Chickasha, Ok 73018.

Please call the Community Development Department at 405-222-6010 or email jessica.green@chickasha.org should you have any questions regarding this petition.

There will also be a public hearing on this petition at the April 6th, 2026, City Council meeting at Chickasha City Hall, 117 North 4th Street, Chickasha Oklahoma.

Sincerely,

Jessica Green

Jessica Green,
Community Development Director

SPECIAL CERTIFICATE

STATE OF OKLAHOMA }
 }
COUNTY OF GRADY } SS:

The Undersigned, lawfully bonded abstracters in and for said County and State, hereby certify that the foregoing attached sheets contain a true and complete list of all property owners owning property with in a 300 foot radius of the following described premises, to wit:

Lot 5 & S 25' of Lot 6 in Block 95 of the City of Chickasha, Grady County, Oklahoma, according to the recorded plat thereof.

AND

N 75' of Lot 6 in Block 95 of the City of Chickasha, Grady County, Oklahoma, according to the recorded plat thereof.

as such list appears in the records of the County Treasurer of Grady County, Oklahoma.

Dated at Chickasha, Oklahoma, this 14th day of January, A.D. 2025 at 7:59 A.M.

COCHRAN ABSTRACT COMPANY

By *Denise Null*

ORDER #73269

Compiled by

COCHRAN ABSTRACT COMPANY
INCORPORATED

BONDED ABSTRACTERS

Hal M. Lee, Manager

C330-00-001-001-0-000-00 21-07-07-05850 ALL LOTS 1-2-3-4 BLK 1
FES SAISS PROPERTIES, LLC HARDEN'S ADDN

4301 AVALON CT

	Acres	Book-Page	Situs
OKLAHOMA COUNTY 73120-0000	0.29	4249/23	906 FRISCO

C330-00-001-005-0-000-00 21-07-07-05900 ALL LOTS 5-6 BLK 1
NICHOLS, ESTHER HARDEN'S ADDN

709 N. 9TH STREET

	Acres	Book-Page	Situs
CHICKASHAOK 73018-0000	0.14	3770/277	709 N 9TH

C330-00-001-007-0-000-00 21-07-07-05950 ALL LOTS 7 THRU 13-LESS N 10'
RITTER, PATRICIA LOT 13 BLK 1 HARDEN'S ADDN

715 N 9TH STREET

	Acres	Book-Page	Situs
CHICKASHAOK 73018-	0.47	6377/343	715 N 9TH

C001-00-095-008-0-000-00 28-07-07-54750 N 75' LOT 8 BLK 95
BUCHANNAN, BRIAN & CLAIRESSA CHICKASHA-OT
SHELTON
627 N 9TH STREET

	Acres	Book-Page	Situs
CHICKASHAOK 73018-0000	0.28	4626/492	627 N 9TH

C001-00-007-017-0-000-00 28-07-07-10050 ALL LOT 17 BLK 7
INGRAM, BRADLEY & CAROL POTTE CHICKASHA-OT

628 N 9TH STREET

	Acres	Book-Page	Situs
CHICKASHAOK 73018-0000	0.29	4152/308	628 N 9TH

C001-00-095-001-0-001-00 28-07-07-54500 W 10' LOT 1 & E 85' LOT 2 & W 5'
LANGE, WILLIAM LOT 2 BLK 95 CHICKASHA-OT

906 W. MICHIGAN AVE

	Acres	Book-Page	Situs
CHICKASHAOK 73018-0000	0.36	5899/483	906 MICHIGAN

C001-00-007-011-0-000-00 28-07-07-09850 ALL LOTS 11 THRU 14 BLK
HIGHLAND TRAILS, LLC 7 CHICKASHA-OT

600 S. WASHINGTON STREET

	Acres	Book-Page	Situs
ARDMORE OK 73401-0000	0.38	5381/280	824 MICHIGAN

Title

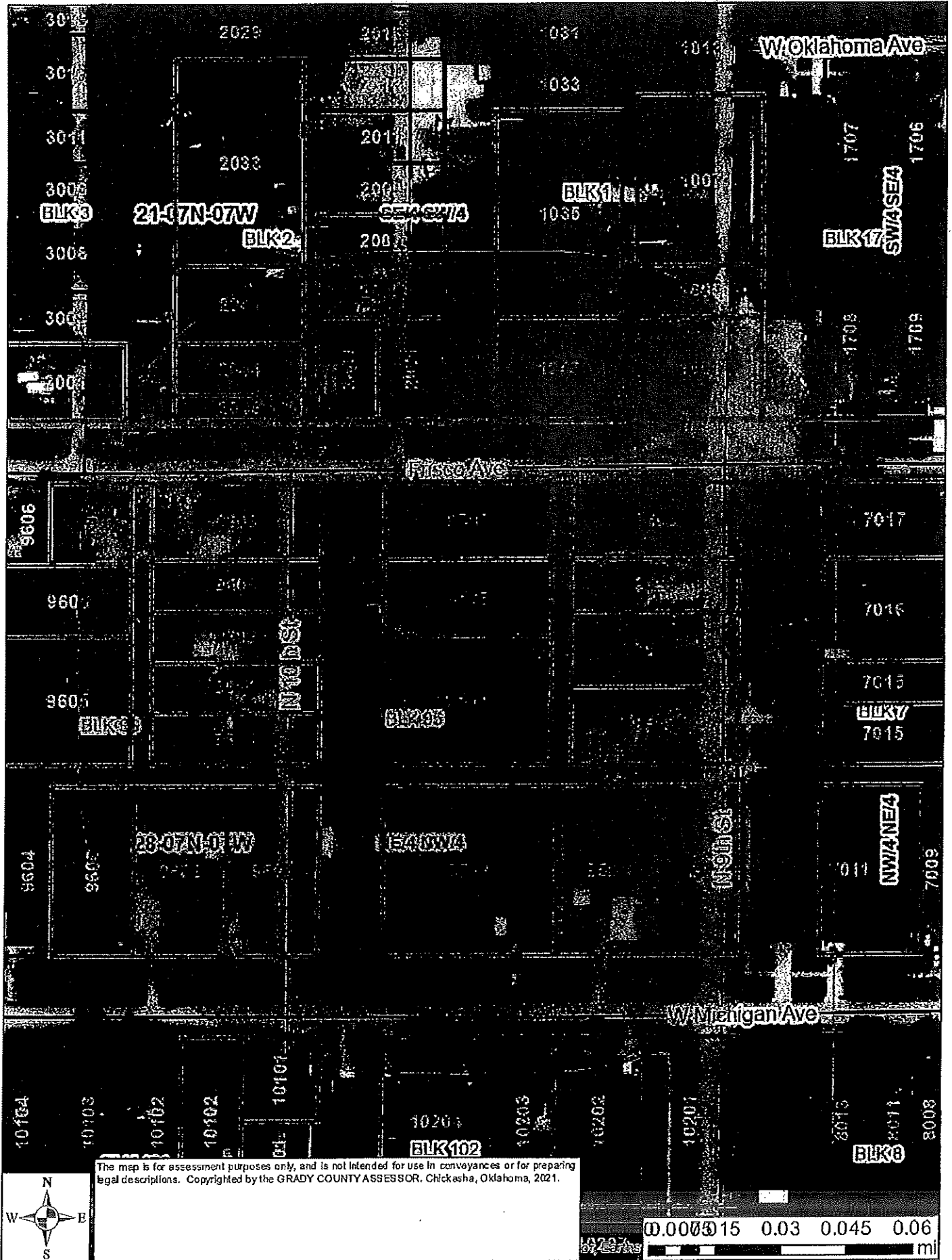

C001-00-095-009-0-000-00 28-07-07-54800 S 1.5' LOT 8 & N 50' LOT 9 BLK
HIGHLAND TRAILS, LLC 95 CHICKASHA-OT

600 S. WASHINGTON STREET

	Acres	Book-Page	Situs
ARDMORE OK 73401-0	0.19	5384/24	623 N 9TH

C001-00-095-001-0-000-00 28-07-07-54450 E 80' LOT 1 BLK 95
GOATES, RAYMOND R. CHICKASHA-OT

902 W MICHIGAN AVE

	Acres	Book-Page	Situs
CHICKASHAOK 73018-0000	0.3	4058/100	902 MICHIGAN

C001-00-007-016-0-000-00 28-07-07-10000 ALL LOT 16 BLK 7
CARR, EUGENE CHICKASHA-OT

620 N. 9TH STREET

	Acres	Book-Page	Situs
CHICKASHAOK 73018-0000	0.38	4821/108	620 N 9TH

C001-00-102-003-0-000-00 28-07-07-57750 E 60' LOT 3 BLK
EYES ON PROPERTIES LLC 102 CHICKASHA-OT

P.O. BOX 14954

	Acres	Book-Page	Situs
OKLAHOMAOKTY 73113-	0.23	6382/486	915 MICHIGAN

C330-00-002-007-0-000-00 21-07-07-06500 ALL LOTS 7-8 BLK 2
LOVELESS, JOHNNY RAY & SUZANN HARDEN'S ADDN
MARIE
707 N. 10TH STREET

	Acres	Book-Page	Situs
CHICKASHAOK 73018-0000	0.14	6308/220	707 N 10TH

C001-00-096-007-0-000-00 28-07-07-55300 N 5' OF E 80' LOT 6 & E 80' LOT 7
HAWTHORN, AMBER BLK 96 CHICKASHA-OT

1219 N. NORTHWOOD AVENUE

	Acres	Book-Page	Situs
REPUBLIC MO 65738-	0.15	6555/183	1015 FRISCO

C001-00-096-008-0-000-00 28-07-07-55350 ALL LOT 8 BLK 96
TORRALBA, PAUL R & ELENOR R. CHICKASHA-OT

3105 CARLTON DR

	Acres	Book-Page	Situs
HIGH RIDGEMO 63049-	0.28	6555/183	627 N 10TH

C001-00-095-003-0-000-00
BRYANS, ROBERT SHAWN

LOTS 3 & 4 BLOCK 95 OT-CHICKASHA

P.O. BOX 324

	Acres	Book-Page	Situs
MEDICINE PARK 73557	0.64	5825/277	N/A

C001-00-095-010-0-001-00
LAIL, PEGGY

28-07-07-54900

S 75' LOT 10

BLK 95

CHICKASHA-OT

% ROY WARD ST.

	Acres	Book-Page	Situs
CHICKASHAOK 73018-0000	0.28	3249/505	615 N 9TH

C001-00-102-004-0-000-00
HIGHLAND TRAILS, LLC

28-07-07-57800
BLK 102

W 30' LOT 3 & ALL LOT 4
CHICKASHA-OT

600 S. WASHINGTON STREET

	Acres	Book-Page	Situs
ARDMORE OK 73401-0	0.42	5384/24	925 W MICHIGAN

C001-00-095-010-0-000-00
BISER, DANIEL H. & CYNTHIA M.

28-07-07-54850
95

S 50' LOT 9 & N 25' LOT 10 BLK
CHICKASHA-OT

29582 AVOCA RD

	Acres	Book-Page	Situs
WANETTE OK 74878-0000	0.28	4027/496	619 N 9TH

C001-00-007-015-0-001-00
HIGHLAND TRAILS, LLC

28-07-07-09950

N 42' LOT 15

BLK 7

CHICKASHA-OT

600 S. WASHINGTON STREET

	Acres	Book-Page	Situs
ARDMORE OK 73401	0.16	5384/24	616 N 9TH

C001-00-007-015-0-000-00
HIGHLAND TRAILS, LLC

28-07-07-09900

S 58' LOT 15

BLK 7

CHICKASHA-OT

600 S. WASHINGTON STREET

	Acres	Book-Page	Situs
ARDMORE OK 73401	0.22	5384/24	614 N 9TH

C001-00-102-001-0-000-00
HIGHLAND TRAILS, LLC

28-07-07-57600

LOT 1

BLK 102

CHICKASHA-OT

600 S. WASHINGTON STREET

	Acres	Book-Page	Situs
ARDMORE OK 73401-0000	0.34	5384/24	901 MICHIGAN

C330-00-002-001-0-000-00 BCP, LLC	21-07-07-06350 HARDEN'S ADDN	E 65' LOTS 1-2-3-4	BLK 2
--------------------------------------	---------------------------------	--------------------	-------

602 S. 4TH STREET

CHICKASHAOK	73018-0000	Acres 0.15	Book-Page 4977/247	Situs 1002 FRISCO
-------------	------------	---------------	-----------------------	----------------------

C330-00-002-046-0-000-00 TORRALBA, PAUL RICHARD &	21-07-07-07200 HARDEN'S ADDN	ALL LOT 46	BLK 2
------------------------------------------------------	---------------------------------	------------	-------

3105 CARLTON DR

HIGH RIDGEMO	63049-	Acres 0.07	Book-Page 2855/389	Situs 702 N 11TH
--------------	--------	---------------	-----------------------	---------------------

C330-00-002-041-0-000-00 POOL, JIMMY	21-07-07-07100 HARDEN'S ADDN	ALL LOTS 41-42-43	BLK 2
-----------------------------------------	---------------------------------	-------------------	-------

710 N. 11TH

CHICKASHAOK	73018-0000	Acres 0.22	Book-Page 4598/585	Situs 710 N 11TH
-------------	------------	---------------	-----------------------	---------------------

C330-00-002-033-0-000-00 POOL, JIMMY LEE	21-07-07-07050 BLK 2	ALL LOTS 33-34-35-36-37-38-39-40 HARDEN'S ADDN	
---------------------------------------------	-------------------------	---------------------------------------------------	--

710 N. 11TH

CHICKASHAOK	73018-0	Acres 0.57	Book-Page 4471/37	Situs 726 N 11TH
-------------	---------	---------------	----------------------	---------------------

C330-00-002-005-0-000-00 BCP, LLC	21-07-07-06450 HARDEN'S ADDN	ALL LOTS 5-6	BLK 2
--------------------------------------	---------------------------------	--------------	-------

602 S. 4TH STREET

CHICKASHAOK	73018-0000	Acres 0.14	Book-Page 4372/584	Situs 705 N 10TH
-------------	------------	---------------	-----------------------	---------------------

C330-00-002-001-0-001-00 VARGHESE, THOMAS & DITTY	21-07-07-06400 HARDEN'S ADDN	W 60' LOTS 1-2-3-4	BLK
------------------------------------------------------	---------------------------------	--------------------	-----

1006 FRISCO AVE

CHICKASHAOK	73018-0000	Acres 0.14	Book-Page 6181/224	Situs 1006 FRISCO
-------------	------------	---------------	-----------------------	----------------------

C330-00-002-044-0-000-00 LITTLEMAN, AMBER KAY	21-07-07-07150 HARDEN'S ADDN	ALL LOT 44-45	BLK 2
--------------------------------------------------	---------------------------------	---------------	-------

706 N. 11TH STREET

CHICKASHAOK	73018-0000	Acres 0.14	Book-Page 4031/265	Situs 706 N 11TH
-------------	------------	---------------	-----------------------	---------------------

C001-00-096-003-0-000-00 28-07-07-55050 E 80' LOT 3 BLK 96
SEYLER, VICKI CHICKASHA-OT

1026 W. MICHIGAN AVE

		Acres	Book-Page	Situs
CHICKASHAOK	73018-0000	0.3	5854/52/53	1026 W MICHIGAN

C001-00-096-009-0-000-00 28-07-07-55400 N 50' LOT 9 BLK 96
WORLEY, SETH CHICKASHA-OT

625 N 10TH STREET

		Acres	Book-Page	Situs
CHICKASHAOK	73018-0000	0.19	5587/369	625 N 10TH

C001-00-096-001-0-000-00 28-07-07-54950 ALL LOT 1 BLK 96
FERRELL, PATSY CHICKASHA-OT

C/O ALBERT LITTLEMAN

		Acres	Book-Page	Situs
CHICKASHAOK	73018-0000	0	4354/67	1002 MICHIGAN

C001-00-096-002-0-000-00 28-07-07-55000 ALL LOT 2 BLK 96
PATEL, MITESH & ANKIT CHICKASHA-OT

3012 BROOKE RD

		Acres	Book-Page	Situs
CHICKASHAOK	73018	0.34	4968/470	1010 MICHIGAN

C001-00-096-010-0-001-00 28-07-07-55550 N 1/2 LOT 10 BLK 96
CHRISTIAN, RODNEY L. SR. & SH CHICKASHA-OT
RRI ALEN
1980 COUNTY ROAD 1366

		Acres	Book-Page	Situs
BLANCHARDK	73010-0000	0.19	6304/437	619 N 10TH

C001-00-096-006-0-000-00 28-07-07-55200 S 70' OF N 75' LOT 6 BLK
BALLARD, JUDY L. 96 CHICKASHA-OT

626 N 11TH STREET

		Acres	Book-Page	Situs
CHICKASHAOK	73018-0000	0.27	5165/582	626 N 11TH

C001-00-096-009-0-001-00 28-07-07-55450 S 1/2 LOT 9 BLK 96
CHRISTIAN, RODNEY L. SR. & SH CHICKASHA-OT
RRI ALEN
1980 COUNTY ROAD 1366

		Acres	Book-Page	Situs
BLANCHARDK	73010-0000	0.19	6304/173	621 N 10TH

C001-00-101-002-0-000-00 28-07-07-57250 W 15' LOT 1 & E 45' LOT 2
ARELLANO, JUAN ESTRADA BLK 101 CHICKASHA-OT

5182 DULUTH COURT

DENVER	CO	80239-0000	Acres	Book-Page	Situs
			0.23	5917/47	1009 MICHIGAN

C001-00-101-002-0-000-00 28-07-07-54700 ALL LOT 7 BLOCK
SMITH, BRANDON T. 95 CHICKASHA-OT

2309 BEVERLY HILLS ST.

NORMAN	OK	73072-0000	Acres	Book-Page	Situs
			0.28	6003/236	628 N 10TH

C001-00-101-002-0-000-00 21-07-07-06250 ALL LOT 35 THRU 42 BLK
FULL GOSPEL CHURCH CONT. - M 1 HARDEN'S ADDN
RISA I MOORE
722 N 10TH

CHICKASHAOK	73018-0000	Acres	Book-Page	Situs
		0.57	2931/535	N/A

C001-00-101-002-0-000-00 21-07-07-06300 LOTS 43 THRU 46 BLK 1
FULL GOSPEL CHURCH, INC HARDEN'S ADDN

722 N 10TH

CHICKASHAOK	73018-0000	Acres	Book-Page	Situs
		0.29	3279/513	918 FRISCO

C001-00-101-002-0-000-00 21-07-07-06300 LOTS 43 THRU 46 BLK 1
FULL GOSPEL CHURCH, INC HARDEN'S ADDN

722 N 10TH

CHICKASHAOK	73018-0000	Acres	Book-Page	Situs
		0.29	3279/513	N/A

C001-00-101-002-0-000-00 28-07-07-57700 ALL LOT 2 BLK 102
GREEN, WILLIAM TRAVIS & TRACY CHICKASHA-OT
LEWIS
911 WEST MICHIGAN AVE

CHICKASHAOK	73018-0000	Acres	Book-Page	Situs
		0.34	6166/327	911 MICHIGAN

C001-00-101-002-0-000-00 28-07-07-54650 N 75' LOT 6 BLK 95
SMITH, BRANDON CHICKASHA-OT

2309 BEVERLY HILLS ST.

NORMAN	OK	73072-0000	Acres	Book-Page	Situs
			0	6259/353	624 N 10TH

C001-00-101-002-0-000-00 28-07-07-54600 ALL LOT 5 & S 25' LOT 6 BLK 95
SMITH, BRANDON CHICKASHA-OT

2309 BEVERLY HILLS ST.

	Acres	Book-Page	Situs
NORMAN OK 73072-0000	0	6259/353	620 N 10TH

C001-00-101-002-0-000-00 21-07-07-07250 ALL LOTS 1-2-3 BLK 3
LITTLEMAN, ALBERT & TAMMY HARDEN'S ADDN

706 N. 11TH STREET

	Acres	Book-Page	Situs
CHICKASHAOK 73018-0000	0.22	4524/136	701 N 11TH

C001-00-101-002-0-000-00 28-07-07-55150 ALL LOT 5 & S 25' LOT 6
DREADIN, ROBERT SHAWN BLK 96 CHICKASHA-OT

2419 COUNTY STREET 2935

	Acres	Book-Page	Situs
BLANCHARD OK 73010-0	0.47	6130/361	N/A

C001-00-101-002-0-000-00 28-07-07-55500 S 50' LOT 10 BLK 96
MOSIER, CALLYN CHICKASHA-OT

617 N. 10TH ST.

	Acres	Book-Page	Situs
CHICKASHAOK 73018-	0.19	6467/505	617 N 10TH

C001-00-101-002-0-000-00 28-07-07-57200 N 82.5' OF E 75' LOT 1
GLA JGM OK, LLC BLK 101 CHICKASHA-OT

1460 BADOVINAC DR.

	Acres	Book-Page	Situs
ROSEVILLE CA 95747-	0.14	6442/537	1001 MICHIGAN

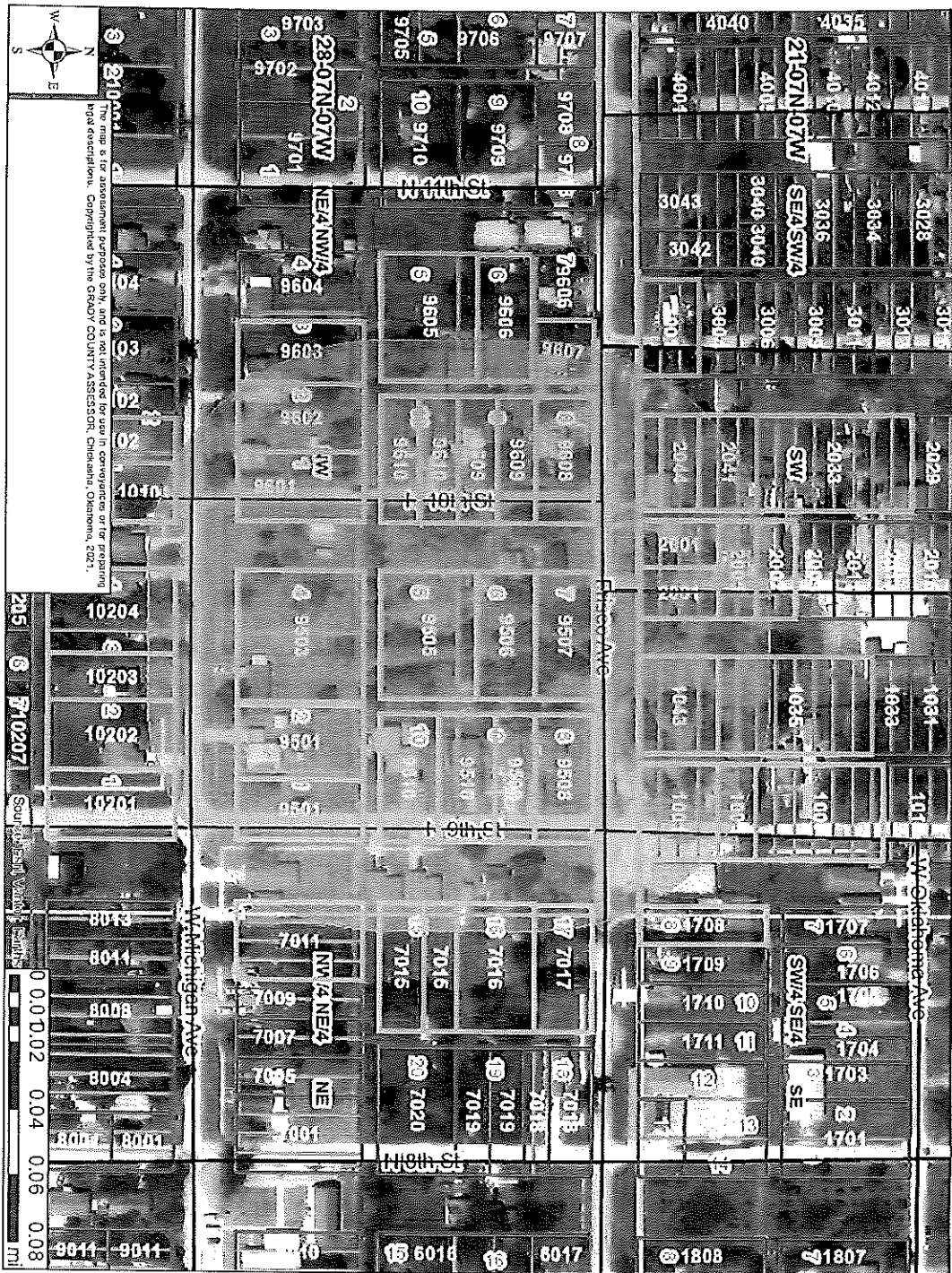

Title

PROOF OF PUBLICATION

In the District Court of Grady County, State of Oklahoma

620 & 624 N. 10TH

Affidavit of Publication

State of Oklahoma, County of Grady, ss:

I, the undersigned publisher, editor or Authorized Agent of the Chickasha Daily Express, do solemnly swear that the attached advertisement was published in said paper as follows:

02/19/2026

That said newspaper is Weekly, in the city of Chickasha, Grady County, Oklahoma, a Weekly newspaper qualified to publish legal notices, advertisements and publications as provided in Section 106 of Title 25, Oklahoma Statutes 1971, as amended, and complies with all other requirements of the laws of Oklahoma with reference to legal publications.

That said Notice, a true copy of which is attached hereto, was published in the regular edition of said newspaper during the period and time of publications and not in a supplement, on the above noted dates.

[Signature]
Signature

Subscribed and sworn before me on this 19th day of February, 2026

[Signature]
Katherine Miller, Notary Public
My commission expires 07/26/2028
Commission # 24009395



Cost of Publication \$ 58.02

Ad # 167877 Acct # 44095 Copies: 1

PAY TO:
The Express Star
PO Drawer E
Chickasha, OK 73023

Published In
The Express-Star
February 19, 2026
1 time
LPXLP
NOTICE OF PUBLIC HEARING
PC PETITION
REQUEST FOR A REZONING
FROM R-1 TO R-2
NOTICE IS HEREBY GIVEN, that the City of Chickasha Planning Commission will hold a public hearing beginning at 4:00 p.m. on Tuesday, March 10th, 2026, at Chickasha City Hall, 117 North 4th Street., Chickasha, Oklahoma. This public hearing is regarding the petition by Brandon Smith requesting a rezone on 2 lots from R-1 to R-2 on the following described properties:
620 N 10th - 28-07-07-54600 ALL LOT 5 & S 25' LOT 6 BLK 95 CHICKASHA-OT
624 N 10th - 28-07-07-54650 N 75' LOT 6 BLK 95 CHICKASHA-OT
BRIEF DESCRIPTION OF REQUEST: The applicant wishes to rezone these lots in order to build duplexes on them.
Any person supporting or having any objections to this petition may appear before the Planning Commission on the above date set for hearing and show cause why the petition should or should not be approved. Written comments regarding this petition should be emailed to jessica.green@chickasha.org or be mailed to City of Chickasha, Community Development Department, 117 North 4th street Chickasha, Ok 73018. Please call the Community Development Department at 405-222-6010 or email jessica.-green@chickasha.org should you have any questions regarding this petition.
There will also be a public hearing on this petition at the April 6th, 2026, City Council meeting at Chickasha City Hall, 117 North 4th Street, Chickasha Oklahoma.
Sincerely,
Jessica Green,
Community Development Director

PROOF OF PUBLICATION

In the District Court of Grady County, State of Oklahoma

620 & 624 N. 10TH

Affidavit of Publication

State of Oklahoma, County of Grady, ss:

I, the undersigned publisher, editor or Authorized Agent of the Chickasha Daily Express, do solemnly swear that the attached advertisement was published in said paper as follows:

02/19/2026

That said newspaper is Weekly, in the city of Chickasha, Grady County, Oklahoma, a Weekly newspaper qualified to publish legal notices, advertisements and publications as provided in Section 106 of Title 25, Oklahoma Statutes 1971, as amended, and complies with all other requirements of the laws of Oklahoma with reference to legal publications.

That said Notice, a true copy of which is attached hereto, was published in the regular edition of said newspaper during the period and time of publications and not in a supplement, on the above noted dates.

[Handwritten Signature]
Signature

Subscribed and sworn before me on this 19th day of February, 2026

[Handwritten Signature: Katherine Miller]
Katherine Miller, Notary Public
My commission expires 07/26/2028
Commission # 24009395

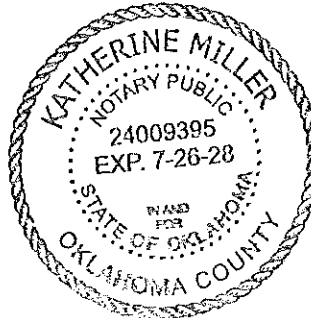

Cost of Publication \$ 58.02

Ad # 167877 Acct # 44095 Copies: 1

PAY TO:
The Express Star
PO Drawer E
Chickasha, OK 73023

Published In
The Express-Star
February 19, 2026
1 time
LPXLP
**NOTICE OF PUBLIC HEARING
PC PETITION
REQUEST FOR A REZONING
FROM R-1 TO R-2**
NOTICE IS HEREBY GIVEN, that the City of Chickasha Planning Commission will hold a public hearing beginning at 4:00 p.m. on Tuesday, March 10th, 2026, at Chickasha City Hall, 117 North 4th Street., Chickasha, Oklahoma. This public hearing is regarding the petition by Brandon Smith requesting a rezone on 2 lots from R-1 to R-2 on the following described properties:
620 N 10th - 28-07-07-54600 ALL LOT 5 & S 25' LOT 6 BLK 95 CHICKASHA-OT
624 N 10th - 28-07-07-54650 N 75' LOT 6 BLK 95 CHICKASHA-OT
BRIEF DESCRIPTION OF REQUEST: The applicant wishes to rezone these lots in order to build duplexes on them.
Any person supporting or having any objections to this petition may appear before the Planning Commission on the above date set for hearing and show cause why the petition should or should not be approved. Written comments regarding this petition should be emailed to jessica.green@chickasha.org or be mailed to City of Chickasha, Community Development Department, 117 North 4th street Chickasha, Ok 73018. Please call the Community Development Department at 405-222-6010 or email jessica.green@chickasha.org should you have any questions regarding this petition.
There will also be a public hearing on this petition at the April 6th, 2026, City Council meeting at Chickasha City Hall, 117 North 4th Street, Chickasha Oklahoma.
Sincerely,
Jessica Green,
Community Development Director

CHICKASHA

Meeting Type: Council Agenda 4-6-2026

Meeting Date: 4/6/2026

Department: Community Development

Agenda Item No. 6.e.

AGENDA ITEM: Discussion, consideration and possible action to approve Ordinance 2026-08 rezoning request for 624 N 10th for applicant Brandon Smith from R-1 to R-2.

I. BACKGROUND/DESCRIPTION:

II. RECOMMENDED ACTION:

Approve Ordinance 2026-08 as presented.

III. FISCAL INFORMATION -

IV. FUND INFORMATION:

Dept. Director:	Fund	Account	Amount
Jessica Green, Community Development Director	(To)		
	FUND	ACCOUNT	AMOUNT
Meeting Date: April 6, 2026	(From)		

V. ATTACHMENTS:

1. Ord. 2026-08 624 N 10th Zoning Change

ORDINANCE NO. 2026-08

AN ORDINANCE OF THE MAYOR AND COUNCIL OF THE CITY OF CHICKASHA, GRADY COUNTY, STATE OF OKLAHOMA, AMENDING THE ZONING MAP AND ZONING ORDINANCES BY CHANGING THE ZONING DISTRICT FOR REAL PROPERTY LOCATED AT 624 N. 10TH CHICKASHA, OKLAHOMA, FROM R-1 SINGLE-FAMILY RESIDENTIAL DISTRICT TO R-2: TWO-FAMILY RESIDENTIAL DISTRICT; PROVIDING FOR REPEALER; PROVIDING FOR SEVERABILITY; AND ESTABLISHING AN EFFECTIVE DATE.

WHEREAS, the City of Chickasha has adopted zoning regulations pursuant to Title 11 of the Oklahoma Statutes §§ 43-101 et seq. and Chapter 54 of the Chickasha Code of Ordinances including Section 54-187; and

WHEREAS, Section 54-187 requires that all applications for zoning amendments include a certified abstractor produced list of all property owners within a 300 foot radius of the exterior boundary lines of the property proposed to be rezoned and requires that mailed notice be provided to all such property owners at least twenty 20 days prior to the Planning Commission hearing; and

WHEREAS, the applicant provided the required certified abstractor produced list identifying all property owners within the 300 foot notification radius and the City caused mailed notice to be sent to all owners listed therein at least twenty 20 days prior to the Planning Commission hearing; and

WHEREAS, in accordance with Section 54-187 and 11 O.S. § 43-104 public notice of the Planning Commission and City Council hearings was published at least fifteen 15 days prior to the hearing in a newspaper of general circulation in the City; and

WHEREAS, the Planning Commission held a duly noticed public hearing on March 10, 2026 at which all interested persons including nearby property owners were afforded an opportunity to be heard and the Planning Commission thereafter voted to recommend approval of the zoning amendment; and

WHEREAS, the City Council thereafter conducted its own properly noticed public hearing in accordance with Oklahoma law and Section 54-187 and finds that the requested zoning amendment is appropriately compatible with surrounding uses consistent with the City's Comprehensive Plan and promotes the public health safety and welfare;

NOW THEREFORE BE IT ORDAINED BY THE MAYOR AND COUNCIL OF THE CITY OF CHICKASHA STATE OF OKLAHOMA:

SECTION 1. The zoning map and zoning ordinances of the City of Chickasha are hereby amended by changing the zoning district classification of the following described real property from R-1 Single-Family Residential District to R-2: Two-Family Residential District, to wit:

The N 75' of Lot 6 in Block 95 of the City of Chickasha, Grady County, Oklahoma according to the recorded plat thereof.

Commonly known as 624 N. 10th Chickasha, Oklahoma.

SECTION 2. Repealer. All ordinances or parts thereof which are inconsistent with this ordinance are repealed upon the effective date of this ordinance.

SECTION 3. Severability. If any section subsection sentence clause phrase or portion of this ordinance is held invalid or unconstitutional such portion shall be deemed a separate independent provision and shall not affect the validity of the remaining portions.

SECTION 4. Effective Date and Publication. This ordinance shall take effect thirty 30 days after its passage approval and publication as required by law.

Adopted and approved this 6th day of April 2026.

Zachary Grayson, Mayor

ATTESTED:

Susan McDaniel, CMC - City Clerk (SEAL)

CHICKASHA

Meeting Type: Council Agenda 4-6-2026

Meeting Date: 4/6/2026

Department: Community Development

Agenda Item No. 6.f.

AGENDA ITEM: Public Hearing to discuss and consider the Rezoning for 620 N 10th from R-1 to R-2 for applicant Brandon Smith.

I. BACKGROUND/DESCRIPTION:

II. RECOMMENDED ACTION:

Hold Public Hearing.

III. FISCAL INFORMATION -

IV. FUND INFORMATION:

Dept. Director: Jessica Green, Community Development Director	Fund (To)	Account	Amount
	FUND	ACCOUNT	AMOUNT
Meeting Date: April 6, 2026	(From)		

V. ATTACHMENTS:

CHICKASHA

Meeting Type: Council Agenda 4-6-2026

Meeting Date: 4/6/2026

Department: Community Development

Agenda Item No. 6.g.

AGENDA ITEM: Discussion, consideration and possible action to approve Ordinance 2026-09 - Rezoning request for 620 N 10th for applicant Brandon Smith from R-1 to R-2.

I. BACKGROUND/DESCRIPTION:

II. RECOMMENDED ACTION:

Approve Ordinance 2026-09 as presented.

III. FISCAL INFORMATION -

IV. FUND INFORMATION:

Dept. Director:	Fund	Account	Amount
Jessica Green, Community Development Director	(To)		
	FUND	ACCOUNT	AMOUNT
Meeting Date: April 6, 2026	(From)		

V. ATTACHMENTS:

1. Ord. 2026-09 620 N. 10th Zoning Change

ORDINANCE NO. 2026-09

AN ORDINANCE OF THE MAYOR AND COUNCIL OF THE CITY OF CHICKASHA, GRADY COUNTY, STATE OF OKLAHOMA, AMENDING THE ZONING MAP AND ZONING ORDINANCES BY CHANGING THE ZONING DISTRICT FOR REAL PROPERTY LOCATED AT 620 N. 10TH CHICKASHA, OKLAHOMA, FROM R-1 SINGLE-FAMILY RESIDENTIAL DISTRICT TO R-2: TWO-FAMILY RESIDENTIAL DISTRICT; PROVIDING FOR REPEALER; PROVIDING FOR SEVERABILITY; AND ESTABLISHING AN EFFECTIVE DATE.

WHEREAS, the City of Chickasha has adopted zoning regulations pursuant to Title 11 of the Oklahoma Statutes §§ 43-101 et seq. and Chapter 54 of the Chickasha Code of Ordinances including Section 54-187; and

WHEREAS, Section 54-187 requires that all applications for zoning amendments include a certified abstractor produced list of all property owners within a 300 foot radius of the exterior boundary lines of the property proposed to be rezoned and requires that mailed notice be provided to all such property owners at least twenty 20 days prior to the Planning Commission hearing; and

WHEREAS, the applicant provided the required certified abstractor produced list identifying all property owners within the 300 foot notification radius and the City caused mailed notice to be sent to all owners listed therein at least twenty 20 days prior to the Planning Commission hearing; and

WHEREAS, in accordance with Section 54-187 and 11 O.S. § 43-104 public notice of the Planning Commission and City Council hearings was published at least fifteen 15 days prior to the hearing in a newspaper of general circulation in the City; and

WHEREAS, the Planning Commission held a duly noticed public hearing on March 10, 2026 at which all interested persons including nearby property owners were afforded an opportunity to be heard and the Planning Commission thereafter voted to recommend approval of the zoning amendment; and

WHEREAS, the City Council thereafter conducted its own properly noticed public hearing in accordance with Oklahoma law and Section 54-187 and finds that the requested zoning amendment is appropriately compatible with surrounding uses consistent with the City's Comprehensive Plan and promotes the public health safety and welfare;

NOW THEREFORE BE IT ORDAINED BY THE MAYOR AND COUNCIL OF THE CITY OF CHICKASHA STATE OF OKLAHOMA:

SECTION 1. The zoning map and zoning ordinances of the City of Chickasha are hereby amended by changing the zoning district classification of the following described real property from R-1 Single-Family Residential District to R-2: Two-Family Residential District, to wit:

Lot 5 & S 25' of Lot 6 in Block 95 of the city of Chickasha, Grady County, Oklahoma, according to the recorded plat thereof.

Commonly known as 620 N. 10th Chickasha, Oklahoma.

SECTION 2. Repealer. All ordinances or parts thereof which are inconsistent with this ordinance are repealed upon the effective date of this ordinance.

SECTION 3. Severability. If any section subsection sentence clause phrase or portion of this ordinance is held invalid or unconstitutional such portion shall be deemed a separate independent provision and shall not affect the validity of the remaining portions.

SECTION 4. Effective Date and Publication. This ordinance shall take effect thirty 30 days after its passage approval and publication as required by law.

Adopted and approved this 6th day of April 2026.

Zachary Grayson, Mayor

ATTESTED:

Susan McDaniel, City Clerk (SEAL)

CHICKASHA

Meeting Type: Council Agenda 4-6-2026

Meeting Date: 4/6/2026

Department: Community Development

Agenda Item No. 6.h.

AGENDA ITEM: Discussion, consideration and possible action to approve a release of credit for Enclave Estates Phase 1.

I. BACKGROUND/DESCRIPTION:

All required public improvements have been completed.

II. RECOMMENDED ACTION:

Approve a release of credit for Enclave Estates Phase 1.

III. FISCAL INFORMATION -

IV. FUND INFORMATION:

Dept. Director:	Fund	Account	Amount
Jessica Green, Community Development Director	(To)		
	FUND	ACCOUNT	AMOUNT
Meeting Date: April 6, 2026	(From)		

V. ATTACHMENTS:

1. Enclave Estates at Chickasha - LOC Release Letter



March 16, 2026

City of Chickasha
Community Development Department
117 N 4th Street
Chickasha, OK 73018

RE: Request for Release of Letter of Credit

Project: Enclave Estates at Chickasha Section 2

To Whom It May Concern,

On behalf of the developer of *Enclave Estates at Chickasha, Section 1*, we respectfully request the release of the letter of credit associated with the public improvements for this project.

All required public improvements have been completed in accordance with the approved plans and City requirements, to the City's satisfaction. All applicable inspections have been performed and approved, and the project is in compliance with City standards.

Based on the completion and acceptance of these improvements, we respectfully request that the City Council authorize the release of the letter of credit at its earliest convenience.

Sincerely,

Loyd Leon Spaugy III, P.E.

CHICKASHA

Meeting Type: Council Agenda 4-6-2026

Meeting Date: 4/6/2026

Department: Community Development

Agenda Item No. 6.i.

AGENDA ITEM: Discussion, consideration and possible action to approve a Bond for Enclave Estates for Phase 2

I. BACKGROUND/DESCRIPTION:

This is for phase 2 for Enclave estates. This bond covers the utilities and paving.

II. RECOMMENDED ACTION:

Recomend approval

III. FISCAL INFORMATION -

IV. FUND INFORMATION:

Dept. Director:	Fund	Account	Amount
Jessica Green, Community Development Director	(To)		
	FUND	ACCOUNT	AMOUNT
Meeting Date: April 6, 2026	(From)		

V. ATTACHMENTS:

1. AL105338 Enclave Estates at Chickasha Section 2 Bond

PERFORMANCE SURETY BOND

We, Enclave Estates at Chickasha Phase II, LP, having offices at
1189 Wilmette Avenue, Unit #316, Wilmette, IL 60091

_____ as principal, and
N/A

as co-principals and **First Indemnity of America Insurance Company** having offices at **2740 Route 10, Suite 205, Morris Plains, NJ**, a corporation duly authorized to transact business in the State of Oklahoma, are indebted to the City of Chickasha, obligee, in the sum of _____

Eight Hundred Thousand and 00/100 Dollars (\$800,000)

for which payment we bind ourselves and our respective heirs, legal representatives, successors, and assigns, jointly and severally.

On _____ (date), applicant Enclave Estates at Chickasha Phase II, LP, principal, was granted approval by the Chickasha City Council "Municipality" of the _____
State of Oklahoma

(approving authority) for final site plan approval for premises known as the improvements subject to this bond are as follows: Paving and Utilities for Phase II

The certification of the cost of such improvements by the municipal engineer is attached hereto and made a part hereof.

Pursuant to Chapter 46 of the Chickasha Code, the principal hereby furnishes a performance surety bond in the amount of (\$800,000.00) Eight Hundred Thousand and 00/100 Dollars

(not to exceed 110 percent of the cost of the improvements as certified by the municipal engineer), written by **First Indemnity of America Insurance Company**, a surety licensed in the State of NJ, guaranteeing full and faithful completion of improvements approved by the approving authority, in lieu of completing the required improvements prior to the granting of final approval.

This bond is issued pursuant to Section 46-45 of the City of Chickasha Land Development Code and in connection with the developer's agreement to complete required public improvements associated with the approved development. These improvements are subject to review and acceptance by the City Council of the City of Chickasha.

This bond shall remain in full force and effect until such time as all improvements covered by the bond have been approved or accepted by Chickasha City Council, except that in those instances where some of the improvements are approved or accepted by resolution of the governing body upon certification by the municipal engineer, partial release from the bond shall be granted. The amount of the bond remaining shall be sufficient to secure provision of the improvements not yet approved.

This bond is issued subject to the following expressed conditions:

1. This bond shall not be subject to cancellation either by the principal or by the surety for any reason until such time as all improvements subject to the bond have been accepted by the Chickasha City Council.
2. This bond shall be deemed to be continuous in form and shall remain in full force and effect until the improvements are accepted by the Chickasha City Council and the bond is released, or until default is declared, or until the bond is replaced by another bond meeting applicable legal requirements. Upon approval or acceptance of all improvements by the Chickasha City Council, or upon replacement of this bond by another bond, liability under this bond shall cease. Upon approval or acceptance of some, but not all, of the required improvements by the Chickasha City Council, partial release from the bond shall be granted in accordance with the Municipal Ordinances, the bond amount must equal 110% of the estimated construction costs of the required improvements; provided, however, that the portion of the bond amount sufficient to secure completion of the improvements shall continue in effect.
3. The aggregate liability of the surety under this bond shall not exceed the sum set forth above.
4. In the event that the improvements subject to this bond are not completed within the time allowed under the conditions of the final approval issued including such extensions as may be allowed by the approving authority, Chickasha City Council, at its option, and upon at least 30 days prior written notice to the principal and to the surety by personal delivery or by certified or registered mail or courier, declare the principal to be in default and, in the event that the surety fails or refuses to complete the work in accordance with the terms and conditions of the original approval, claim payment under this bond shall be made for the cost of the completion of the work. In the event that any action is brought against the principal under this bond, written notice of such action shall be given to the surety by the municipality by personal delivery or by registered or certified mail or courier at the same time.
5. The surety shall have the right to complete the work in accordance with the terms and conditions of the original approval, subject to Chickasha City Council approval and inspection, either with its own employees or in conjunction with the principal or another contractor; provided, however, that the surety, in its sole discretion, may make a monetary settlement with the municipality as an alternative to completing the work.

6. In the event that the principal and the approving authority agree to changes in the scope of work, the obligations of the surety under this bond shall not be affected so long as the cost of the work does not exceed 110 percent of the municipal engineer's certified estimate, attached hereto and made a part hereof, which 110 percent of the estimate shall be the limit of the surety's obligation under this bond in any case. If the cost of the work exceeds 110 percent of the certified estimate, the principal shall secure a rider from a surety for the additional amount; provided, however, that this provision shall not be construed as requiring a surety to provide additional coverage.

7. This bond shall inure to the benefit of the municipality only and no other party shall acquire any rights hereunder.

8. In the event that this bond shall for any reason cease to be effective prior to the approval or acceptance of all improvements, a cease and desist order may be issued by the governing body, in which case all work shall stop until such time as a replacement guarantee acceptable to the approving authority becomes effective.

9. This bond may not be assigned by the Principal or Surety without written consent of the City of Chickasha; however, any transfer of ownership of the property subject to the required improvements shall not relieve the Principal or Surety of their obligations under this bond unless the City Council expressly releases this bond or approved replacement security.

Date: This 20th day of March, 2026

SEAL:

PRINCIPAL NAME HERE

Witness
/Attest:

BY: Enclave Estates as Chickasha Phase II, LP

Name: _____

Title: _____

Princip
al

First Indemnity of America
Insurance Company

SEAL:

By: Anne Schevker
Witness/Attest as to Surety
Anne Schevker

By: Adam T. Grap
Attorney-in-Fact Adam T. Grap



**FIRST INDEMNITY OF AMERICA
INSURANCE COMPANY**
2740 Route 10 West, Suite 205 Morris Plains, N.J. 07950
Telephone: (973) 402-1200

POWER OF ATTORNEY FOR BONDS AND UNDERTAKINGS

Know All Men By These Presents: That First Indemnity of America Insurance Company, a Corporation of the State of New Jersey does hereby appoint: Jaime Lynn George-Perando, Adam T. Grap, Manuel Jones, Aldo Pasquariello, Karen L. Wilson, Maki F. Tyree, Anne Schevker, Stephen A. Spencer, Daniel R. West, Brenda L. Pattishall, Susan B. Willett, Beatrice Saint-Felix, Ryan Hays, Rohan Nabar, Bruce Alan Pattishall, its true and lawful Attorneys-in-Fact: to make, execute, sign, acknowledge, affix the Company Seal to, deliver any and all surety bonds, Consents of Surety, undertakings, recognizances and other contracts of indemnity and writings obligatory in the nature of a bond, for and on behalf of said Company and as an act and deed of said Company.

IN WITNESS WHEREOF, First Indemnity of America Insurance Company of the State of New Jersey has executed these presents this 21st day of May, 2025.





Patrick J. Lynch, President

STATE OF NEW JERSEY)
COUNTY OF MORRIS) ss:

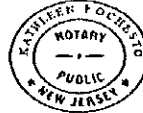
On this 21st day of May, 2025, before me came the above named authorized representative of First Indemnity of America Insurance Company, to me personally known to be the individual and representative described herein, and acknowledge that he executed the foregoing instrument and affixed the seal of the said corporation thereto by authority of this office.

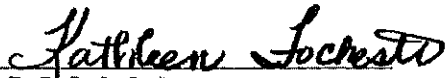

KATHLEEN FOCHESTO
Commission # 2394310
Notary Public, State of New Jersey
My Commission Expires
March 16, 2030

CERTIFICATE

Excerpts of Resolutions adopted by the Board of Directors of First Indemnity of America Insurance Company of the State of New Jersey adopted May 21, 2025.

RESOLVED, that the President, or any one of the Vice Presidents specially authorized to do so by the Board of Directors, shall have the power to appoint Attorneys-in-Fact as the business of the company may require, or to authorize any person or persons to execute on behalf of the Company any bonds, Consents of Surety, undertakings, recognizances, stipulations, policies, contracts, agreements, deeds, and release and assignment of judgments, decrees, mortgages and instruments in the nature of mortgages, and also all other instruments and documents which the business of the Company may require and to affix the Seal of the Company thereto.

FURTHER RESOLVED, that the signatures and attestations of such officers and the seal of the Company may be affixed to any such Power of Attorney or to any certificate relating to the Power of Attorney by electronic means and any such Power of Attorney or certificate bearing such electronic signatures or electronic seal shall be valid and binding upon the Company with respect to any bond, undertaking, recognizances or other contract of indemnity of writing obligatory in the nature thereof.

I, Jane E. Lynch, Secretary of First Indemnity of America Insurance Company of New Jersey, do hereby certify that the foregoing Resolutions were adopted by the Board of Directors of the Corporation and the Powers of Attorney issued pursuant thereto, are true and correct and that both the Resolution and the Powers of Attorney are in full force and effect.

IN WITNESS WHEREOF, I have herewith set my hand and affixed the seal of said Corporation this 21st day of May, 2025.
This is notice that the Power of Attorney cited above is effective this 20th day of March, 2026.

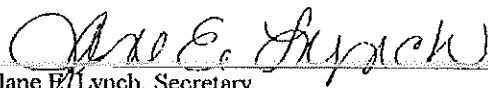

Jane E. Lynch, Secretary

AL105338

State of  Oklahoma

Carroll Fisher
Insurance Commissioner
Oklahoma City, Oklahoma

Whereas, *the*

FIRST INDEMNITY OF AMERICA INSURANCE COMPANY

a corporation organized under the laws of NJ

and located at 119 LITTLETON ROAD
PARSIPPANY, NJ 07054

having complied with the Insurance laws of Oklahoma, is hereby licensed and authorized to transact the business of

SURETY

This Certificate of Authority shall be perpetual and automatically renewed as of March 1st of every year, unless the insurer fails to qualify for renewal pursuant to the requirements of Title 36 of the Oklahoma Insurance Code.



In Witness Whereof, I have hereunto set my hand and caused the seal of my office to be affixed at the City of Oklahoma City, State of Oklahoma, this

1st day of MARCH A.D. 2003

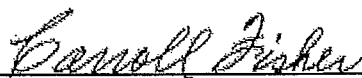

Carroll Fisher
Insurance Commissioner State of Oklahoma

Oklahoma License # 3041

CHICKASHA

Meeting Type: Council Agenda 4-6-2026

Meeting Date: 4/6/2026

Department: Community Development

Agenda Item No. 6.j.

AGENDA ITEM: Discussion, consideration and possible action to approve Final Plat for Enclave Estates Phase 2.,

I. BACKGROUND/DESCRIPTION:

This was approved by planning commission. They will start pulling permits May 1st for 31 homes and two common areas.

II. RECOMMENDED ACTION:

Recomend approval

III. FISCAL INFORMATION -

IV. FUND INFORMATION:

Dept. Director: Jessica Green, Community Development Director	Fund (To)	Account	Amount
	FUND	ACCOUNT	AMOUNT
Meeting Date: April 6, 2026	(From)		

V. ATTACHMENTS:

1. Enclave Estates at Chickasha 2 FP 03.19.26

FINAL PLAT OF ENCLAVE ESTATES AT CHICKASHA SECTION 2

A PART OF THE NE/4 OF SECTION 6, T6N, R7W, I.M.
CHICKASHA, GRADY COUNTY, OKLAHOMA

LINE TABLE		
LINE #	LENGTH	DIRECTION
L1	35.36'	N45° 01' 50"W
L2	35.36'	N44° 58' 10"E
L3	35.36'	S45° 01' 50"E
L4	35.36'	S44° 58' 10"W

CURVE TABLE					
CURVE #	LENGTH	RADIUS	DELTA	CHORD DIRECTION	CHORD LENGTH
C1	22.25'	35.00'	036°25'43"	S71° 45' 19"W	21.88'
C2	147.80'	52.00'	162°51'26"	S45° 01' 50"E	102.84'
C3	22.25'	35.00'	036°25'43"	N18° 11' 02"E	21.88'
C4	22.25'	35.00'	036°25'43"	N18° 14' 41"W	21.88'
C5	106.93'	52.00'	117°49'16"	S67° 29' 15"W	89.06'
C6	22.25'	35.00'	036°25'43"	N71° 48' 58"W	21.88'

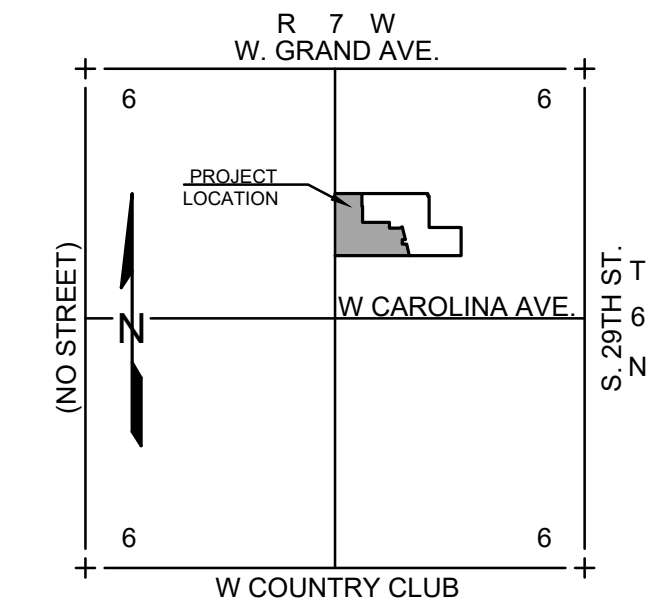
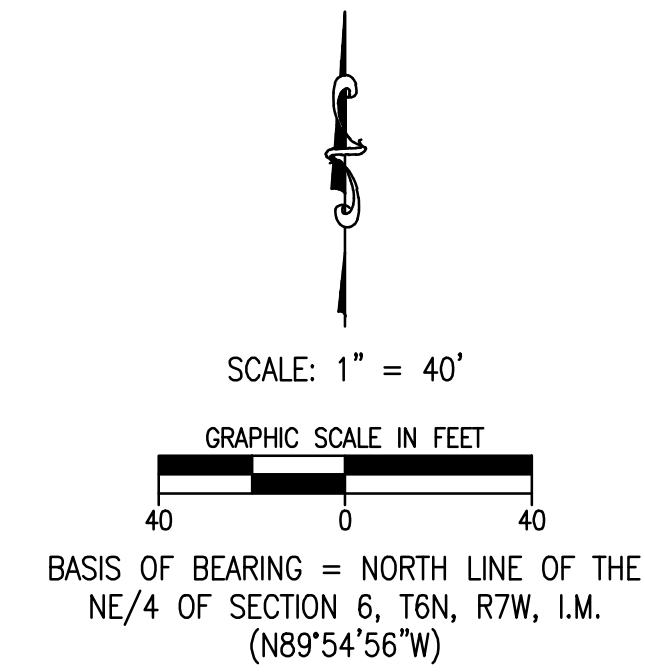

Parcel Table			Parcel Table		
LOT #	BLOCK #	Area	LOT #	BLOCK #	Area
1	10	6,999 S.F.	6	10	6,000 S.F.
1	09	6,000 S.F.	7	10	6,000 S.F.
1	08	6,600 S.F.	7	09	6,000 S.F.
2	10	6,000 S.F.	8	10	6,000 S.F.
2	09	6,000 S.F.	8	09	6,888 S.F.
2	08	6,887 S.F.	9	10	6,000 S.F.
3	10	6,000 S.F.	10	10	6,000 S.F.
3	09	6,887 S.F.	11	10	6,794 S.F.
3	08	6,000 S.F.	12	10	8,508 S.F.
4	10	6,000 S.F.	13	10	11,380 S.F.
4	09	6,887 S.F.	14	10	7,077 S.F.
4	08	6,000 S.F.	15	10	6,599 S.F.
5	10	6,000 S.F.	16	10	6,002 S.F.
5	09	6,000 S.F.	17	10	6,002 S.F.
5	08	6,197 S.F.	18	10	6,002 S.F.
6	09	6,000 S.F.	19	10	6,602 S.F.

LEGEND

- P.O.B. POINT OF BEGINNING
- EX. EXISTING
- R/W RIGHT-OF-WAY
- BL BUILDING LIMIT LINE
- UE UTILITY EASEMENT
- DE DRAINAGE EASEMENT
- PDE PRIVATE DRAINAGE EASEMENT
- (NR) NONRADIAL LINE
- L.N.A. LIMITS OF NO ACCESS
- C/A COMMON AREA

NOTES

1. This plat of survey meets the Oklahoma Minimum Standards for the Practice of Land Surveying as adopted by the Oklahoma State Board of Licensure for Professional Engineers and Land Surveyors and that said Final Plat complies with the requirements of Title 11, Section 41-108 of the Oklahoma State Statutes.
2. Monuments shall be as follows:
Magnetic Nail with Washer stamped "CTA CA973" for all Paved Surfaces or
3/8" Iron Rod with a Plastic Cap stamped "CTA CA973"
3. Maintenance of the Common Areas and Islands/Medians in Public Rights-of-Way shall be the responsibility of the Property Owners and/or Property Owners Association. No structures, storage of material, grading, fill, or other obstructions, either temporary or permanent shall be placed within the drainage related common areas and/or drainage areas shown. Certain amenities such as, but not limited to, walks, benches, piers, and docks, shall be permitted if installed in a manner to meet the requirements specified above.
4. A sidewalk is required on each lot where it abuts a local and/or a collector street. The sidewalk is required at the Building Permit Stage and must be installed prior to the issuance of a Certificate of Occupancy from the City of Oklahoma City for the applicable lot.
5. Two 1/2 inch caliper trees, or one 3-inch caliper tree, shall be planted in the front yard of all lots where the garage extends beyond the front wall of a residence, towards the street Right-of-Way.
6. Any addresses shown on this plat were accurate at the time this plat was filed. Addresses are subject to change and should never be relied upon in place of legal description.

FINAL PLAT
ENCLAVE ESTATES AT CHICKASHA SECTION 2

300 Points Parkway Blvd.
Yukon, Oklahoma 73099

Crafton Tull
architecture | engineering | surveying
405.787.6270 | 405.787.6276.1
www.craftontull.com

SHEET NO.: 2 OF 2
DATE: 03/19/26
PROJECT NO.: 25607300

CERTIFICATE OF AUTHORIZATION
CA 973 (P&S) EXPIRES 6/30/2026

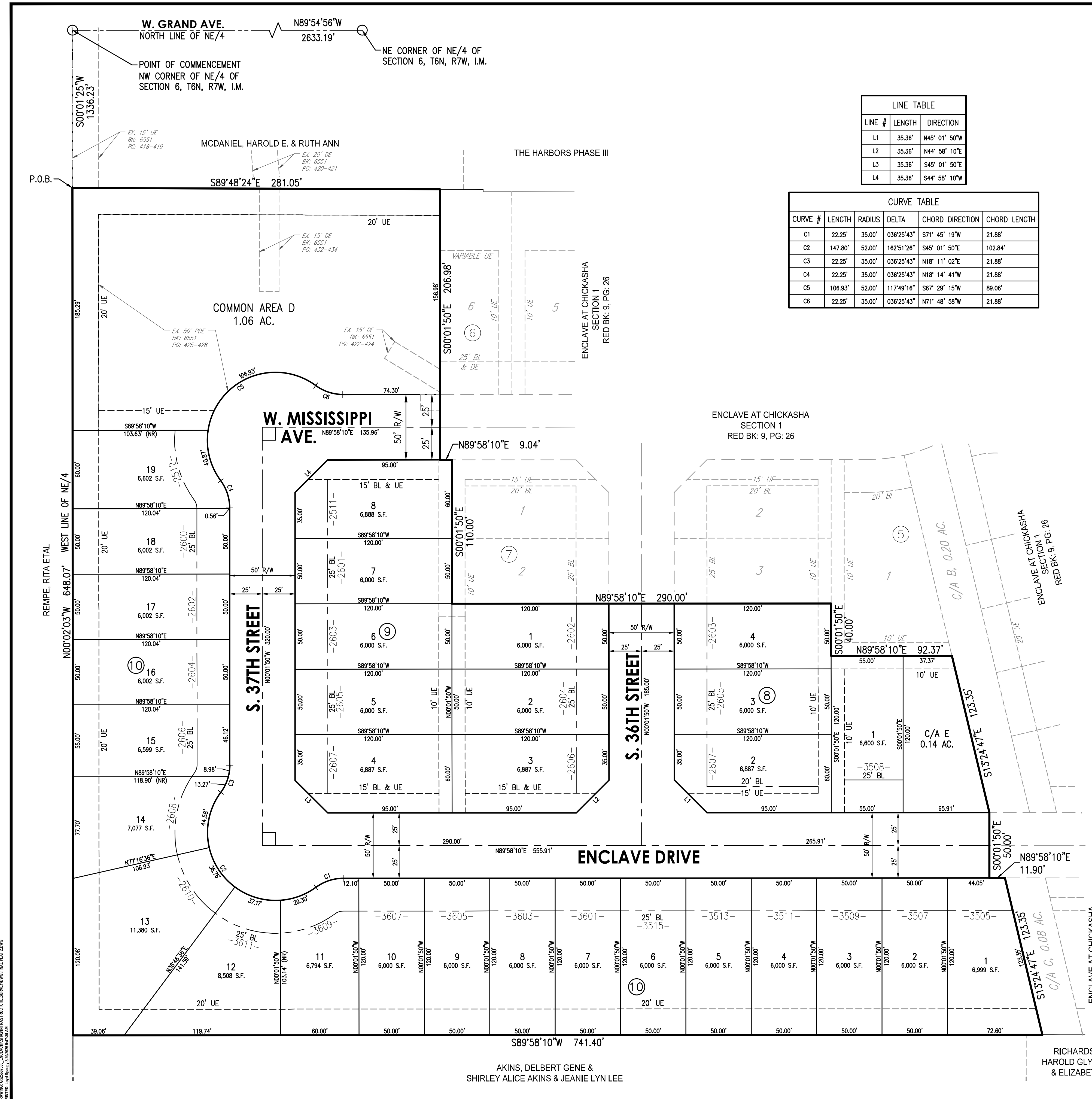

DRAWING: G:\SHIRLEY\ENCLAVE ESTATES AT CHICKASHA SECTION 2\ENCLAVE ESTATES AT CHICKASHA SECTION 2.DWG
DATE: 03/19/26 10:58:38 AM
PLOT: 11x17

CHICKASHA

Meeting Type: Council Agenda 4-6-2026

Meeting Date: 4/6/2026

Department: Community Development

Agenda Item No. 6.k.

AGENDA ITEM: Discussion, consideration and possible action to approve a service agreement with Smith Roberts Baldischwiler, LLC (SRB) for GIS database.

I. BACKGROUND/DESCRIPTION:

Establish or enhance the City’s GIS database, Provide GIS Software Support and Training. This will be for our zoning map that will allow the public and staff access to. This allows SRB to modify and make changes to the zoning map.

II. RECOMMENDED ACTION:

Recommend approval

III. FISCAL INFORMATION -

IV. FUND INFORMATION:

Dept. Director:	Fund	Account	Amount
Jessica Green, Community Development Director	(To)		
	FUND	ACCOUNT	AMOUNT
Meeting Date: April 6, 2026	(From)		

V. ATTACHMENTS:

1. City of Chickasha GIS Proposal for General Services (1)



March 10, 2026

Jim Crosby
City Manager
City of Chickasha
City Hall, 2nd Floor
117 N. 4th Street
Chickasha, OK 73018
citymanager@chickasha.org
(405) 222-6045

RE: GIS Mapping General Services

Dear Mr. Crosby,

Smith Roberts Baldischwiler, LLC (SRB) was established in 1981 to provide land development services for a wide range of private sector clients. Over the next 45 years, **SRB** expanded its expertise, growing into a multidisciplinary firm. Our **team of 80+ employees** includes professional engineers; professional land surveyors; geographic information systems professionals; designers; utility coordinators; survey crews; construction inspectors; permitting and support staff. SRB is pleased to provide information for our GIS Services as follows:

1. Introduction

Our team specializes in delivering cost-effective, scalable, and accurate GIS solutions for municipal governments. By leveraging modern mapping technologies, we can help the city enhance its infrastructure management, planning, and citizen engagement.

2. Objectives

The primary objectives of this engagement are to:

- Establish or enhance the City's GIS database.
- Provide accurate mapping of municipal assets (utilities, parcels, rights-of-way, zoning, etc.).
- Support decision-making through data analysis and visualization.
- Improve interdepartmental data sharing and citizen access to maps and information.
- Provide GIS Software Support and Training.

3. Scope of Services

3.1 GIS Database Development

Design and implementation of an Esri-compliant geodatabase.
Integration of existing records, CAD files, paper maps, and other spatial data sources.

3.2 Data Collection & Asset Inventory

Field surveying of municipal infrastructure (stormwater, water, sewer, streets, signage, etc.).
GPS data collection with sub-meter or survey-grade accuracy (as required).
Attribute collection (size, material, condition, maintenance history).

3.3 Data Integration & Quality Control

Conversion and cleaning of existing data.
Establishing domains, relationships, and metadata to ensure long-term usability.
Implementation of QA/QC processes to maintain accuracy.

3.4 Mapping & Analysis

Development of web maps and dashboards for staff and the public.
Custom cartographic products (zoning maps, utility maps, planning maps).
Spatial analysis (service coverage, asset conditions, growth projections).

3.5 Geodatabase Information Model

Design of a municipal geodatabase schema that supports long-term growth and compliance.

Development of feature classes for critical datasets such as:

- Parcels and Property Boundaries (with linkages to assessor/ownership data).
- Utility Infrastructure (stormwater, sanitary sewer, water distribution, electric, gas).
- Transportation Network (streets, rights-of-way, sidewalks).
- Zoning and Land Use (planning layers, future growth areas).
- Public Facilities & Landmarks (parks, schools, municipal buildings).

Definition of attribute domains (e.g., pipe material types, zoning classifications, surface types).

Creation of relationship classes (e.g., parcels ↔ owners, mains ↔ service connections).

Documentation of metadata standards for each dataset.



3.6 Training & Support

Training City staff in ArcGIS Pro and ArcGIS Online/Enterprise.
Ongoing technical support and data maintenance options.

4. Budget

All fees will need to be pre-approved by Task Order.

Our hourly rates for GIS Services and Geospatial Data Collection (sub-meter) are as follows:

GIS Mapping Member Hourly Rates

GIS Data Analyst	\$120.00
GIS Developer	\$175.00
GIS Professional (GISP)	\$215.00
GIS Field Asset Data Collection (sub-meter accuracy)	\$85.00
Field Asset Data Collection (survey-grade accuracy)	\$100.00
GIS Software Support & Training	\$85.00

5. Benefits to the Municipality

Improved decision-making through accurate data.
Long-term cost savings in asset management.
Increased transparency and public access to information.
Scalable system to support future growth and projects.



ENGINEERING | SURVEYING | PLANNING

SMITH ROBERTS BALDISCHWILER, LLC

PERSON OR ENTITY RESPONSIBLE FOR PAYMENT (“CLIENT”):

Name / Company			
Address			
City, State, Zip			
Telephone	Office:	Cell:	Fax:
Email			
Contact	Office:	Cell:	Fax:

PROJECT NAME / DESCRIPTION: _____

SCOPE OF SERVICES/ PROJECT SCHEDULE: See Exhibit A

FEES AND EXPENSES: See Exhibit A Describe: _____

PAYMENT TERMS: See Exhibit A 30 days Other: _____

SRB PROJECT MANAGER: _____ **EMAIL ADDRESS:** _____

PHONE: _____ **FAX:** _____

TERMS

For the consideration recited and mutual promises herein made, incorporating Page 1 as if set forth fully herein, the parties agree:

1. Location of Underground Utilities. The underground utilities shown on any plans or drawings produced or provided by SRB pursuant to this agreement have been located from field survey information, existing drawings, and other available information. SRB makes no guarantee that the underground utilities shown comprise all such utilities in the area, either in service or abandoned, or that the utilities shown are in the exact location indicated. SRB does not physically locate any underground utilities, therefore, unless otherwise expressly provided herein, SRB shall not be responsible for determining the exact location of any underground utilities. Client agrees that the contractor who performs the work shall be required to comply with all applicable statutes, ordinances, codes, rules, and regulations, and specifications regarding location of underground utilities, and shall be required to verify the accuracy of all measurements and the physical location of all underground utilities prior to commencing work or ordering materials.

2. Non-Appropriation Clause. The obligations of the Client under this Agreement are subject to the annual appropriation and availability of funds by the governing body of the Client. In the event that sufficient funds are not appropriated or otherwise made available to support the continuation of this Agreement in any fiscal year, the Client may terminate this Agreement without penalty upon written notice to the Consultant. In such event, the Consultant shall be compensated for all services satisfactorily performed and authorized expenses incurred up to the effective date of termination.

3. Ownership. The City of Chickasha shall retain full ownership of all data, documents, reports, and materials provided to the City.

4. Term Agreement. This Agreement shall remain in effect for a period of one (1) year from the date of execution by both parties, unless terminated earlier in accordance with the terms of this Agreement.

5. Miscellaneous. In case any one or more of the provisions of this Agreement shall be invalid, illegal, or unenforceable in any respect, such provisions shall be adjusted rather than voided, if possible, in order to achieve the intent of the parties to this Agreement to the extent possible and in any event, the validity, legality, and enforceability of the remaining provisions contained herein shall not in any way be affected or impaired thereby. This Agreement shall be governed, construed and interpreted in accordance with the laws of the State of Oklahoma. Jurisdiction and Venue shall lie exclusively in the state and federal courts located in the District Courts of Grady County, Oklahoma. This Agreement is a final expression of the intent of the Parties and shall be modified only by a duly executed written instrument signed by both Parties. Failure to pursue any legal or equitable remedy or right available to a Party shall not constitute a waiver of such right, nor shall any such forbearance, failure or actual waiver imply or constitute waiver of subsequent default or breach. No waiver of a breach of any provision of this Agreement shall be construed to be a waiver of any breach of any other provision of this Agreement or of any succeeding breach of the same provision. No delay in acting with regard to any breach of any provision of this Agreement shall be construed to be a waiver of such provision. The captions to the sections of this Agreement are for convenience only and shall not be considered or referred to in resolving questions of interpretation. This Agreement shall be binding upon the Parties hereto, their respective heirs, successors and assigns, but shall not be assigned by any party hereto without the written consent of the other party. This Agreement may be executed in counter parts, each of which will be deemed an original and all of which together will constitute one instrument.

6. Progressive Billing / Late Payments. Unless provided otherwise herein, all work in progress may be invoiced monthly and is due within ninety (90) days from date of invoice. All past due payments bear interest at the rate of 1.5% per month. If payments are past due, in addition to its right to collect, SRB may suspend work or refuse to deliver the work ordered.

**PERSON OR ENTITY
RESPONSIBLE FOR PAYMENT:**

Name: _____ Date _____
Title: _____

SRB:

Name: Taylor Denniston Date _____
Title: Professional Land Surveyor

CHICKASHA

Meeting Type: Council Agenda 4-6-2026

Meeting Date: 4/6/2026

Department: Finance

Agenda Item No. 6.I.

AGENDA ITEM: Discussion, consideration and possible action to approve an Amendment to the Agreement with Tyler Technologies, Inc. updating payment processing pricing, and authorizing execution of the same.

I. BACKGROUND/DESCRIPTION:

II. RECOMMENDED ACTION:

Approve an Amendment to the Agreement with Tyler Technologies, Inc. updating payment processing pricing, and authorizing execution of the same.

III. FISCAL INFORMATION -

IV. FUND INFORMATION:

Dept. Director: Rich Edwards, Finance Director	Fund	Account	Amount
	(To)		
	FUND	ACCOUNT	AMOUNT
Meeting Date: April 6, 2026	(From)		

V. ATTACHMENTS:

1. Chickasha OK Amend 032026



AMENDMENT

This amendment ("Amendment") is effective as of the date of signature of the last party to sign as indicated below ("Amendment Effective Date"), by and between Tyler Technologies, Inc. with offices at One Tyler Drive, Yarmouth, Maine 04096 ("Tyler") and the City of Chickasha, Oklahoma, with offices at 117 North 4th Street, Chickasha, Oklahoma 73018 ("Client").

WHEREAS, Tyler and the Client are parties to an agreement dated January 21, 2014 ("Agreement"); and

WHEREAS, Tyler and Client desire to amend the terms of the Agreement as provided herein.

NOW THEREFORE, in consideration of the mutual promises hereinafter contained, Tyler and the Client agree as follows:

1. The Tyler Payments pricing set forth in Tyler sales quotation #2022-335303-N9M3J2, signed by Client on July 27, 2023, is hereby replaced in its entirety with the pricing set forth in Exhibit 1 to this Amendment as of the Amendment Effective Date.
2. This Amendment shall be governed by and construed in accordance with the terms and conditions of the Agreement.
3. Except as expressly indicated in this Amendment, all other terms and conditions of the Agreement shall remain in full force and effect.

IN WITNESS WHEREOF, the parties hereto have executed this Amendment as of the dates set forth below.

Tyler Technologies, Inc.

City of Chickasha, Oklahoma

By: _____

By: _____

Name: _____

Name: _____

Title: _____

Title: _____

Date: _____

Date: _____





Exhibit 1
Tyler Payments Pricing

REMAINDER OF PAGE INTENTIONALLY LEFT BLANK



Billing Address:
 CHICKASHA, OK CITY OF
 TRACEY AUSTIN
 117 N 4TH ST
 CHICKASHA OK 73018-2601

Shipping Address
 City of Chickasha
 117 N 4th St

 Chickasha OK 73018-2601

Quoted By Matthew Beltram
 Quote Expiration 9/12/26
 Quote Name Misc. POS Amendment

Payments

	List Price	Service%	Min	Basis Points	Rate	Cap	POS	Online	IVR
Payments - Client Card Cost - Interchange Plus									
ERP Pro Payments									
Utility Billing				0.59%	\$ 0.59		X	X	X
Payments - Payer Card Cost - Service Fees									
ERP Pro Payments									
Miscellaneous		3.95%	\$ 2.50				X		
Municipal Justice Payments									
Municipal Justice		3.95%	\$ 2.50				X	X	X
Payments - Other Fees									
Client eCheck Cost	\$ 1.95								
eCheck Rejects	\$ 5.00								
Credit Card Chargebacks	\$ 15.00								

Client Card Cost - Interchange Plus

per card transaction with Visa, MasterCard, Discover, and American Express, when applicable, for all transactions on top of industry-driven rates for bank fees, card brand fees, interchange fees, dues, assessments, and other processing fees.

Payer Card Cost

per card transaction with Visa, MasterCard, Discover, and American Express when applicable.

Credit Card Chargebacks

If a card payer disputes a transaction at the card issuing bank (e.g. stolen card).

Client eCheck Cost

Per electronic check transaction.

eCheck Rejects

When an eCheck transaction comes back as declined (e.g. bounced check).

Payments

Your use of Payments and any related items included on this order is subject to the terms found at: <https://www.tylertech.com/terms/payment-card-processing-agreement>. By signing this order or the agreement in which it is included, you agree you have read, understand, and agree to such terms. Please see attached Payments fee schedule.

Summary

One Time Fees

Recurring Fees

Total Tyler Services

Summary Total

\$ 0

Comments

2022-335303-N9M3J2

Work will be delivered remotely unless otherwise noted in this agreement.

Expenses associated with onsite services are invoiced as incurred according to Tyler's standard business travel policy.

SaaS is considered a term of one year unless otherwise indicated.

Client agrees that items in this sales quotation are, upon Client's signature or approval of same, hereby added to the existing agreement ("Agreement") between the parties and subject to its terms. Additionally, payment for said items, as applicable but subject to any listed assumptions herein, shall conform to the following terms, subject to payment terms in an agreement, amendment, or similar document in which this sales quotation is included:

- License fees for Tyler and third-party software are invoiced upon the earlier of (i) delivery of the license key or (ii) when Tyler makes such software available accessible.
- Fees for hardware are invoiced upon delivery.
- Fees for year one of hardware maintenance are invoiced upon delivery of the hardware.
- Annual Maintenance and Support fees are first payable when Tyler makes the software accessible to the Client, and SaaS fees, Hosting fees, and Subscription fees are first payable on the first day of the month following the date this quotation was signed (or if later, the commencement of the agreement's initial term). Any such fees are prorated to align with the applicable term under the agreement, with renewals invoiced annually thereafter in accord with the agreement.

Fees for services included in this sales quotation shall be invoiced as indicated below.

- Implementation and other professional services fees shall be invoiced as delivered.
- Client has six months to use the services. If Client does not use the services within six months, Tyler may remove the unused services or issue a new quote to provide services at then-current rates.
- Fixed-fee Business Process Consulting services shall be invoiced 50% upon delivery of the Best Practice Recommendations, by module, and 50% upon delivery of custom desktop procedures, by module.
- Fixed-fee conversions are invoiced 50% upon initial delivery of the converted data, by conversion option, and 50% upon Client acceptance to load the converted data into Live/Production environment, by conversion option. Where conversions are quoted as estimated, Tyler will invoice Client the actual services delivered on a time and materials basis.

- Except as otherwise provided, other fixed price services are invoiced upon complete delivery of the service. For the avoidance of doubt, where "Project Planning Services" are provided, payment shall be invoiced upon delivery of the Implementation Planning document. Dedicated Project Management services, if any, will be invoiced monthly in arrears, beginning on the first day of the month immediately following initiation of project planning.
- If Client has purchased any change management services, those services will be invoiced in accordance with the Agreement.
- Notwithstanding anything to the contrary stated above, the following payment terms shall apply to fees specifically for migrations: Tyler will invoice Client 50% of any Migration Services Fees listed above upon Client approval of the product suite migration schedule. The remaining 50%, by line item, will be billed upon the go-live of the applicable product suite. Tyler will invoice Client for any Project Management Fees listed above upon the go-live of the first product suite. Annual SaaS Fees will be invoiced upon availability of the hosted environment.

Any SaaS or hosted solutions added to an agreement containing Client-hosted Tyler solutions are subject to Tyler's SaaS Services terms found here: <https://www.tylertech.com/terms/tyler-saas-services>.

Unless otherwise indicated in the contract or amendment thereto, pricing for optional items will be held for six (6) months from the Quote date or the Effective Date of the Contract, whichever is later.

Customer Approval: _____ Date: _____

Print Name: _____ P.O.#: _____

CHICKASHA

Meeting Type: Council Agenda 4-6-2026

Meeting Date: 4/6/2026

Department: Administration

Agenda Item No. 6.m.

AGENDA ITEM: Discussion, consideration and possible action to approve an agreement with Dobson Fiber to provide 2GB of internet service with static IP at Shannon Springs Park in a monthly amount not to exceed \$255 and authorize the Mayor to execute the same.

I. BACKGROUND/DESCRIPTION:

Internet is required to provide phone service, which we have already engaged with Dobson fiber for. Phone service is required for the public pool. This internet service will also allow us to offer free public wifi throughout the park during designated hours, separate from a secure network for pool and City staff use, once we install the necessary equipment.

II. RECOMMENDED ACTION:

Approve an agreement with Dobson Fiber to provide 2GB of internet service with static IP at Shannon Springs Park in a monthly amount not to exceed \$255 and authorize the Mayor to execute the same.

III. FISCAL INFORMATION -

IV. FUND INFORMATION:

Dept. Director: Shae Mortimer, Marketing Director	Fund	Account	Amount
	(To)		
	FUND	ACCOUNT	AMOUNT
Meeting Date: April 6, 2026	(From)		

V. ATTACHMENTS:

1. City of Chickasha 2gig Shannon Springs Park



Dobson
F I B E R

Prepared For
CITY OF CHICKASHA
JIM CROSBY

Quote
Q-27752



Service Order

14101 Wireless Way, Suite 300
Oklahoma City, Oklahoma 73134
(405)242-1000 | (888)356-2707

Date: March 17, 2026
Quote: Q-27752
Prepared by: Jacy Trent
Phone:
Email: jtrent@dobson.net

Pricing Valid Through: 4/16/2026
Account Number: 100092247

March 17, 2026

CITY OF CHICKASHA
JIM CROSBY
117 N 4th St
Chickasha, Oklahoma 73018

Dear JIM,

Thank you for choosing Dobson Fiber for your technology needs. Should you have any questions regarding this quote or Dobson Fiber in general, please feel free to reach out to me directly.

Best Regards,

Jacy Trent
14101 Wireless Way, Suite 300
Oklahoma City, Oklahoma 73134
(405) 242-1000 | 855.5.DOBSON
jtrent@dobson.net
<http://www.dobson.net>

The information contained herein is confidential and proprietary and should not be disclosed,
copied or duplicated in any manner without the written permission of Dobson Fiber.



Service Order

14101 Wireless Way, Suite 300
 Oklahoma City, Oklahoma 73134
 (405)242-1000 | (888)356-2707

Date: March 17, 2026
Quote: Q-27752
Prepared by: Jacy Trent
Phone:
Email: jtrent@dobson.net

Pricing Valid Through: 4/16/2026
Account Number: 100092247

BUYER INFORMATION	TERM
CITY OF CHICKASHA JIM CROSBY 117 N 4th St Chickasha, Oklahoma 73018 4052226045 jim.crosby@chickasha.org	36 months

CONTACT	ROLE	PHONE	EMAIL
JIM CROSBY	All	4052226045	jim.crosby@chickasha.org
SHAE MORTIMER	Billing	405-222-6021	shae.mortimer@chickasha.org
SHAE MORTIMER	Testing or Tech Contact	405-222-6021	shae.mortimer@chickasha.org

2400 S 9TH STREET CHICKASHA OK 73018

SERVICE	QTY	NRC Unit Price	NRC Total	MRC Unit Price	MRC Total
Business Internet --- Z Location Geolocation: 35.023043,-97.944697 --- IP Address: Static --- Interface: GigE Copper --- Z Location Bandwidth: 2Gbps	1			\$250.00	\$250.00
Business Internet Standard Installation	1	\$0.00	\$0.00		
Static IP Address --- Interface: FastE (10/100) Copper Interface	1			\$5.00	\$5.00

The information contained herein is confidential and proprietary and should not be disclosed, copied or duplicated in any manner without the written permission of Dobson Fiber.



Service Order

14101 Wireless Way, Suite 300
Oklahoma City, Oklahoma 73134
(405)242-1000 | (888)356-2707

Date: March 17, 2026

Quote: Q-27752

Prepared by: Jacy Trent

Phone:

Email: jtrent@dobson.net

Pricing Valid Through: 4/16/2026

Account Number: 100092247

ADDITIONAL INFORMATION

Add Order

Non-Appropriation of Funds

The Customer's obligation to pay for the services provided under this Service Order is contingent upon the availability of funds appropriated by the Customer. If, in any fiscal year during the term of this Service Order, sufficient funds are not appropriated or otherwise made available for the continuation of any telecom services to the service location listed on this Service Order, the Customer may terminate this Service Order upon written notice to the Seller without further obligation or liability. In such event, the Customer shall be liable only for payment for services rendered and accepted prior to the effective date of termination. The Customer agrees to provide prompt written notice to the Seller if appropriation of funds for this Service Order becomes unavailable.

RECAP	AMOUNT
One-Time (non-recurring) Total	\$0.00
Recurring Monthly Charges	\$255.00

By executing this Service Order, Buyer accepts and agrees to be bound by all terms and provisions of the applicable Product Supplement(s) and Master Service Agreement previously executed or as set forth at www.dobson.net/legal. Taxes and fees may apply.

The installation of Services on this Service Order are subject to 3rd party permit approvals which may impact normal installation timing.

Customer Signature _____

Date _____

The information contained herein is confidential and proprietary and should not be disclosed, copied or duplicated in any manner without the written permission of Dobson Fiber.

CHICKASHA

Meeting Type: Council Agenda 4-6-2026

Meeting Date: 4/6/2026

Department: Administration

Agenda Item No. 6.n.

AGENDA ITEM: Discussion, consideration and possible action to approve an agreement with Standley Systems to add two printers to our contract and authorize the mayor to execute the same.

I. BACKGROUND/DESCRIPTION:

This will add one printer for our new Parks & Recreation Director, Andy Conyers, and one for our Youth Services Librarian, Drew Cooper.

Per Standley Systems, we do not need to sign the "unconditional guaranty" line in the agreement as our contract has a non-appropriations clause.

II. RECOMMENDED ACTION:

III. FISCAL INFORMATION -

IV. FUND INFORMATION:

Dept. Director: Shae Mortimer, Marketing Director	Fund	Account	Amount
	(To)		
	FUND	ACCOUNT	AMOUNT
Meeting Date: April 6, 2026	(From)		

V. ATTACHMENTS:

1. Q022899_Imaging Equipment Schedule to Agreement_Chickasha City of
2. Q022899_Order Summary_Chickasha City of



SCHEDULE TO MASTER AGREEMENT (Imaging Equipment)

Standley Systems
PO Box 460 Chickasha, OK 73023

QUOTE NO. Q022899.	MASTER AGREEMENT NO 3066077-001	APPLICATION NO.	AGREEMENT/SCHEDULE NO.
-----------------------	------------------------------------	-----------------	------------------------

CUSTOMER ("YOU" OR "YOUR")

FULL LEGAL NAME: Chickasha, City of

ADDRESS: 527 W IOWA AVE Chickasha, OK 73018-3445

MASTER AGREEMENT

REFERS TO THE AGREEMENT BETWEEN CUSTOMER AND OWNER IDENTIFIED IN OWNER'S RECORDS BY THE MASTER AGREEMENT NO. ABOVE.

DESCRIPTION OF EQUIPMENT, IMAGE ALLOWANCE AND EXCESS CHARGES

<input type="checkbox"/> SEE ATTACHED EQUIPMENT OR GROUP BILLING SCHEDULE TYPE, MAKE, MODEL NUMBER, SERIAL NUMBER, AND INCLUDED ACCESSORIES	<input type="checkbox"/> NOT FINANCED UNDER THIS AGREEMENT	BEGINNING METER READING			MONTHLY IMAGE ALLOWANCE			EXCESS PER IMAGE CHARGE (PLUS TAX)		
		B&W	COLOR	MICR	B&W	COLOR	MICR	B&W	COLOR	MICR
3QA75A: HP E47528F MANAGED	<input type="checkbox"/>									
3QA75A: HP E47528F MANAGED	<input type="checkbox"/>									
TOTAL CONSOLIDATED MONTHLY IMAGE ALLOWANCE AND EXCESS PER IMAGE CHARGES (IF CONSOLIDATED)					1000	800		0.012600	0.066700	

EQUIPMENT LOCATION: **As Stated Above**

METER FREQUENCY: QUARTERLY

* THE CONSOLIDATED IMAGE ALLOWANCE AND EXCESS PER IMAGE AMOUNTS SHOWN ABOVE (OR ON THE ATTACHED EQUIPMENT LIST), IF ANY, (CHECK ONE):

APPLIES TO EQUIPMENT LISTED UNDER THIS SCHEDULE ONLY, OR

HEREBY REPLACES THE PREVIOUSLY ESTABLISHED CONSOLIDATED IMAGE ALLOWANCE AND EXCESS PER IMAGE AMOUNTS ON SCHEDULE _____ (THE "PRIOR SCHEDULE") IF DIFFERENT, AND INCLUDES THE EQUIPMENT LISTED ON THIS SCHEDULE IN THE CONSOLIDATED IMAGE ALLOWANCE AND EXCESS PER IMAGE AMOUNTS UNDER THE PRIOR SCHEDULE. IF THE SECOND BOX IS CHECKED, AND NO CONSOLIDATED IMAGE ALLOWANCE OR EXCESS PER IMAGE AMOUNTS ARE DESCRIBED ABOVE, THE PARTIES AGREE THAT IMAGES ON THE LISTED EQUIPMENT WILL COUNT TOWARDS THE EXISTING CONSOLIDATED ALLOWANCES AND EXCESS CHARGES UNDER THE PRIOR SCHEDULE.

PAYMENT (CHECK ONE PAYMENT OPTION)

MONTHLY BASE PAYMENT AMOUNT: **\$182.96** (PLUS TAX) (INCLUDES AMOUNTS DUE UNDER THIS SCHEDULE ONLY)

TOTAL CONSOLIDATED MONTHLY BASE PAYMENT AMOUNT: (PLUS TAX) (INCLUDES AMOUNTS DUE UNDER THIS SCHEDULE, THE PRIOR SCHEDULE, AND ANY SCHEDULE WHICH PREVIOUSLY INCLUDED THE PRIOR SCHEDULE IN ITS TOTAL CONSOLIDATED MONTHLY BASE PAYMENT AMOUNT, IF ANY, DURING THE TERM THEREOF)

TERM (CHECK ONE TERM OPTION)

TERM: THE END OF THE TERM OF THIS SCHEDULE IS THE END OF TERM OF SCHEDULE NO. 3066077-001_ (COTERMINOUS)

TERM IN MONTHS: (APPLIES TO THIS SCHEDULE ONLY)

ADDITIONAL TERMS AND CONDITIONS (APPLICABLE TO THIS SCHEDULE ONLY)

IMAGE ALLOWANCE CHARGES AND OVERRAGES. In connection with providing you, or financing for you, the equipment and/or software described above (excluding equipment marked as not financed under this Agreement, the "Equipment"), the Base Payment Amount set forth above includes the amount payable to us each period pursuant to the terms of this Schedule (the "Equipment Payment"), and may include a minimum periodic amount payable to us for maintenance, supplies, or other Services relating to the Equipment and any equipment marked as not financed under this Agreement (the "Maintenance Payment") pursuant to our separate maintenance arrangement with you identified by the Service Agreement Number referenced below (the "Maintenance Agreement"). You are entitled to make the total number of images shown under the Image Allowances each period during the term of this Agreement. If you make more than the allowed images in any period, you will pay us an additional amount equal to the number of the excess images made during such period multiplied by the applicable Excess Image charge. Images made on equipment marked as not financed under this Agreement will be included in determining your image and overage charges. Regardless of the number of images made in any period, you will never pay less than the Base Payment Amount. You agree to allow us to install a Data Collection Agent ("DCA") to facilitate the processing of meter readings. If a DCA is not installed or is disabled, you will be billed an additional \$15 per device per month. If we request you to provide us with meter readings and you fail to do so within seven days of our request, then we may estimate the number of images made and invoice you accordingly. If three consecutive requests for actual meter readings go unanswered, a technician shall be dispatched to the Equipment to gather the meter readings and a charge of \$25.00 per device will be assessed to you. You agree that the Base Payment Amount and the Excess Image charges may be proportionately increased at any time if our estimated average page coverage is exceeded. After the end of the first year of this Agreement and not more than once each successive twelve-month period thereafter, the Base Payment Amount and the Excess Image charges (and, at our election, the Base Payment Amount and Excess Image charges under any subsequent agreements between you and us that incorporate the terms hereof) may be increased by a maximum of 15% of the then existing payment or charge.

Service Agreement No.:

AGREEMENT

This Schedule to Master Agreement ("Schedule"), together with the preprinted terms of the Master Agreement (as amended), constitutes an agreement between Customer and Owner with respect to the equipment referenced herein (or on the attached Equipment List or Group Billing Pool) (excluding equipment marked as not financed under this Agreement), separate and distinct from any other Schedule to Master Agreement entered into between Customer and Owner pursuant to the Master Agreement. Customer agrees to be bound by the terms of this Schedule, which includes the preprinted terms of the Master Agreement (as amended), and agrees this Schedule shall constitute an "Agreement" as such term is used in the Master Agreement. The parties agree that the original hereof for enforcement and perfection purposes, and the sole "record" constituting "chattel paper" under the UCC, is the paper copy hereof bearing (i) the original or a copy of either your manual signature or an electronically applied indication of your intent to enter into this Schedule, and (ii) our original manual signature. If any provision in this Schedule conflicts with a provision in the Master Agreement, the provision in this Schedule shall control. This Schedule shall commence on the date of our acceptance.

CUSTOMER'S AUTHORIZED SIGNATURE

ONCE YOU SIGN THIS SCHEDULE AND OWNER ACCEPTS IT, THIS SCHEDULE WILL BE NON-CANCELABLE FOR THE FULL TERM.

(As Stated Above) X

CUSTOMER	SIGNATURE	PRINT NAME	TITLE	DATE
----------	-----------	------------	-------	------

OWNER ("WE", "US", "OUR")

Standley Systems

OWNER	SIGNATURE	PRINT NAME	TITLE	DATE
-------	-----------	------------	-------	------

UNCONDITIONAL GUARANTY

The undersigned, jointly and severally if more than one, unconditionally guarantee(s) that the Customer will timely perform all obligations under the Schedule. The undersigned also waive(s) any notification if the Customer is in default and consent(s) to any extensions or modifications granted to the Customer. In the event of default, the undersigned will immediately pay all sums due under the terms of the Schedule without requiring us or our assignee to proceed against Customer or any other party or exercise any rights in the Equipment referenced in the Schedule. The undersigned, as to this guaranty, agree(s) to the designated forum and consent(s) to personal jurisdiction, venue, and choice of law as stated in the Master Agreement, agree(s) to pay all costs and expenses, including attorneys' fees, incurred by us or our assignee related to this guaranty and the Schedule, waive(s) a jury trial and transfer of venue, and authorize(s) obtaining credit reports.

SIGNATURE: X	INDIVIDUAL:	DATE:
SIGNATURE: X	INDIVIDUAL:	DATE:



Order Summary

Quote Number: Q022899

CUSTOMER ACCEPTANCE

The undersigned hereby verifies that the information on this Order Summary is complete and correct. The undersigned also acknowledges having received a copy of this Order Summary.

Chickasha, City of			
Customer	Signature	Print Name	Date

QTY	Manufacturer	Make/Model Description	Ship to Address	Ship to City	Bldg/Floor/Room/Dept
1	HP	HP E47528F MANAGED	527 W IOWA AVE	Chickasha	Library - Drew Cooper's Office
1	HP	HP E47528F MANAGED	117 N 4TH ST	Chickasha	Andy Conyers, third floor city hall

CHICKASHA

Meeting Type: Council Agenda 4-6-2026

Meeting Date: 4/6/2026

Department: Public Works

Agenda Item No. 6.o.

AGENDA ITEM: Discussion, consideration, and possible action to accept a quote in the amount of \$47,796.25 from Keystone Services Inc. for maintenance work on the parking lot at the Chickasha Sports Complex.

I. BACKGROUND/DESCRIPTION:

See attached letter from Omar Fierro, Public Works Director

II. RECOMMENDED ACTION:

Accept a quote in the amount of \$47,796.25 from Keystone Services Inc. for maintenance work on the parking lot at the Chickasha Sports Complex.

III. FISCAL INFORMATION -

IV. FUND INFORMATION:

Dept. Director: Omar Fierro, Public Works Director	Fund	Account	Amount
	(To)		
	FUND	ACCOUNT	AMOUNT
Meeting Date: April 6, 2026	(From)		

V. ATTACHMENTS:

- 20260401084815705

Dear Mayor and Council Members,

The Department of Parks and Recs is requesting approval to proceed with a preventative maintenance project focused on repairing City-owned parking lot at the Chickasha Sports Complex through a crack sealing process.

Over time, our asphalt parking lot naturally deteriorated due to traffic wear, temperature fluctuations, moisture infiltration, and Oklahoma's freeze-thaw cycles. What begins as minor surface cracking can quickly develop into larger structural failure, including potholes and base deterioration, if left unaddressed.

Crack sealing is a proactive and cost-effective maintenance strategy designed to extend the life of asphalt pavement. The process involves:

- Cleaning and preparing existing cracks
- Applying a hot rubberized sealant to prevent water intrusion
- Creating a flexible seal that expands and contracts with temperature changes

By sealing cracks early, we prevent water from penetrating the base material beneath the asphalt — which is the primary cause of pavement failure. Once the base becomes compromised, repair costs increase significantly, often requiring full-depth patching or complete resurfacing.

From a financial standpoint, preventative maintenance is substantially more economical than reconstruction. Industry standards consistently show that every dollar spent on preventative maintenance can save several dollars in future replacement costs. This approach allows us to protect our infrastructure investment and stretch taxpayer dollars responsibly.

In addition to cost savings, this project will:

- Improve safety for citizens and visitors
- Enhance the overall appearance of city facilities
- Reduce liability risks associated with deteriorating pavement
- Extend pavement life by several years

Our goal is not simply to repair what is broken, but to preserve what we already have. Taking action now allows us to address minor deficiencies before they become major capital expenditures.

Staff has evaluated the affected parking lot and determined that crack sealing is the appropriate maintenance solution at this time. Delaying this work will likely result in accelerated deterioration and increased costs in future budget cycles.

For these reasons, I respectfully request Council's approval to proceed with the parking lot crack sealing project as presented.

I would be happy to answer any questions.

Sincerely: Public Works Director Omar Fierro



1/6/2025

ESTIMATE
Chickasha
Sports Complex

To: Chickasha Sports Complex

ATT: Omar Fierro Public Works Director
 Ref# SW-816
 CRACK SEAL/Mastic/Routing
omar.fierro@chickasha.org

1/6/2025

<u>Item #</u>	<u>Item ID</u>	<u>Description</u>	<u>Unit</u>	<u>Completed # Units</u>	<u>Price/ Unit</u>	<u>Extension</u>
1	30121500/1000012576	Service Z3 TypeB Bituminous Pavement/Crack Joint Sealant	LBS	11,250.00	\$ 1.45	\$16,312.50
2	30121500/mastic	Mastic	LBS	7,200.00	\$ 3.50	\$25,200.00
3	30121500/10000012580	Routing	LF	25,135.00	\$ 0.25	\$6,283.75
Total						\$47,796.25

*** *Work should take 5 days weather permitting.*

The above is ONLY AN ESTIMATE only the pounds placed are billed and will not exceed the PO amount.

The crack sealing quote is for the random cracks and the joint between the asphalt and the concrete gutter. Mastic is used for the large deep cracks that are over 2 inches in width. Mastic fills and smooths the void as well as it seals the joint.

Routing is chasing or cutting the radom cracks to recess the crack sealant. If you elect not to recess the sealant deduct item 2 and we will band seal the random cracks.

Prior to scheduling we must have a written work order in place.



Oklahoma Statewide Contract Search

Search and explore contracts from the Oklahoma procurement system.

[← Back to Contracts](#)

SW0816M JOINT CRACK SEALANT

Statewide Number: **SW0816M**

PeopleSoft Dispatch Contract ID: **0000000000000000000006927**

Contract Supplier Type: **Direct**

Mandatory **Non-IT** **Oklahoma Solicitation**

Summary

JOINT CRACK SEALANT Provides labor, traffic service, and product. Contact supplier directly for orders. Obtain quote from supplier.

Contacts

OMES

Category Manager: Darlene Saltzman

Email: darlene.saltzman@omes.ok.gov

Supplier

Business Name: KEYSTONE SERVICES INC

PeopleSoft Supplier ID: 0000073669

Contacts:

John Sherment Primary
Email: Keystone@olp.net
Phone: [918-366-4578](tel:918-366-4578)

 **Timing**

Awarded Supplier Contract Date
5/31/2023

Statewide Contract End Date
5/30/2026

 **Attachments (3)**

-  SW0816_KeystoneServicesInc._Pricing_20230518.pdf
Pricing 
-  SW00816M_KeystoneServices_ExecutedContractWithPricing_20250904.pdf
Master Agreement 
-  SW00816M_KeystoneServices_PSDispatch6927_20250904.pdf
PeopleSoft Dispatch 

 **UNSPSC Categories**

[30121500 - Bituminous derivatives](#)

 **Keywords**

CHICKASHA

Meeting Type: Council Agenda 4-6-2026

Meeting Date: 4/6/2026

Department: Library

Agenda Item No. 6.p.

AGENDA ITEM: Discussion, consideration, and possible action to appoint Mary K. Parrish to the Library Advisory Board with a term to expire June 30, 2028.

I. BACKGROUND/DESCRIPTION:

With a vacancy on the Library Advisory Board, the Mayor puts forth Mary K. Parrish to fill the position with a term to expire June 30, 2028.

II. RECOMMENDED ACTION:

Discussion, consideration, and possible action to appoint Mary K. Parrish to the Library Advisory Board with a term to expire June 30, 2028.

III. FISCAL INFORMATION -

IV. FUND INFORMATION:

Dept. Director:	Fund	Account	Amount
	(To)		
	FUND	ACCOUNT	AMOUNT
Meeting Date: April 6, 2026	(From)		

V. ATTACHMENTS:

- 20260401104056311



CITY OF CHICKASHA

APPLICATION FOR BOARD OR COMMISSION MEMBERSHIP

Return completed application to:
 City Clerk's Office
 117 North 4th Street
 Chickasha, OK 73018
 Fax: 405-222-6004

Please type or use black ink
 For questions or additional information, call the City Clerk's Office, (405) 222-6001

Name: MARY K. PARRISH

(Please print legal name and your name as you wish it to appear, if different.)

Personal Information	Occupational Information
Home Address: <u>33 PARKWAY DRIVE</u>	Business Name: <u>RETIRED</u>
Mailing Address: <u>same</u>	Occupation: _____
Telephone: <u>405-323-9777</u> Fax: _____	Address: _____
E-Mail: <u>mary.parrish17@gmail.com</u>	Telephone: _____ Fax: _____
Chickasha Resident for <u>8</u> years County: <u>GRADY</u>	E-Mail: _____
Drivers License No.: _____	

Which Council Ward do you live in? 1

Prior work experience: *(please include dates)*
Teacher - 40 years - Retired 2017

Educational Achievement:

High School Graduate? Yes No Year Graduated/Left School? 1970
 Business College, Correspondence School, Adult Education, Other? _____
 Name of College/University: OU Bachelor's Master's PhD

Volunteer Work: (please include dates)

OHCE - Various types - 2018 - present
Library - 2017 - present
Reading tutoring - 2 yrs

I AM INTERESTED IN SERVING ON THE FOLLOWING BOARDS OR COMMISSIONS:
 (Please limit your selection to no more than three. List in order of preference: 1, 2, 3.)

- | | |
|---------------------------------------------------------------------------------------------------------------------|----------------------------------------------------------------------------------------------------------------------------------------------------|
| <p>___ Aviation Board</p> <p>___ Board of Adjustment</p> <p>___ Cemetery Board</p> <p>___ Board of Code Appeals</p> | <p>___ Historic Preservation Commission</p> <p>___ Chickasha Industrial Authority</p> <p>___ Library Board</p> <p>___ Keep Chickasha Beautiful</p> |
|---------------------------------------------------------------------------------------------------------------------|----------------------------------------------------------------------------------------------------------------------------------------------------|

Am I presently serving on a City board or commission? Yes No

If so, please list: _____

Please list any abilities, skills, licenses, certificates, specialized training, or interests you have which are applicable to this board or commission:

Organization skills, writing abilities, reading & research abilities
dependable work values, believe libraries are essential

Are you presently serving on or have experience on a board or commission other than the City of Chickasha? Yes No

If so, please list: Cleveland County Historical Society

Please specify any business or personal relationships with the City or other activities, which might create a serious conflict of interest or affect your ability to serve if you should be appointed to this board or commission:

NONE

Have you attended a meeting of the board/commission you are applying to or talked to anyone currently on the board? Yes No

Comments: _____

References:

Lillie Huckaby - DIRECTOR, CHICKASHA PUBLIC LIBRARY

Brandi Bradford - ASSISTANT DIRECTOR, CHICKASHA PUBLIC LIBRARIES

Statement of Intent

I am aware of the requirements of the City regarding conflicts of interest of appointees to the City of Chickasha Boards and Commissions. I am aware of meeting dates and times of the Board/Commission for which I have applied, and that Board/Commission members are expected to attend a minimum of 75 percent of regularly scheduled meetings annually of their Board/Commission. If appointed, I agree to serve on the Board/Commission for which I have applied. Applications will remain on file for one year from the date of receipt.

**I affirm that I am qualified to vote.*

Signature: Mary Parrish

Date: March 9, 2025

CHICKASHA

Meeting Type: Council Agenda 4-6-2026

Meeting Date: 4/6/2026

Department: Community Development

Agenda Item No. 6.q.

AGENDA ITEM: Discussion, consideration, and possible action on Resolution 2026-12R — A RESOLUTION OF THE CITY COUNCIL OF THE CITY OF CHICKASHA, GRADY COUNTY, STATE OF OKLAHOMA, AUTHORIZING THE INSTALLATION OF CERTAIN STREETLIGHTS BY AMERICAN ELECTRIC POWER AT SPECIFIED LOCATIONS WITHIN THE CITY; PROVIDING FOR PAYMENT OF THE APPLICABLE MONTHLY CHARGES; AND PROVIDING FOR AN EFFECTIVE DATE.

I. BACKGROUND/DESCRIPTION:

The street lights will be installed throughout the Enclave Estates.

(1) 45W Post Top LED Contemporary Streetlight, Location: Corner of W. Mississippi Ave. and S. 35th St.

(1) 45W Post Top LED Contemporary Streetlight, Location: Corner of S. 35th St. and Enclave Dr.

(1) 45W Post Top LED Contemporary Streetlight, Location: Corner of Enclave Dr. and S. 34th St.

(1) 45W Post Top LED Contemporary Streetlight, Location: Corner of W. Mississippi Ave. and S. 36th St.

II. RECOMMENDED ACTION:

Approve Resolution 2026-12R as presented.

III. FISCAL INFORMATION -

IV. FUND INFORMATION:

Dept. Director: Jessica Green, Community Development Director	Fund (To)	Account	Amount
	FUND	ACCOUNT	AMOUNT
Meeting Date: April 6, 2026	(From)		

V. ATTACHMENTS:

1. Res. 2026-12R Streetlight Resolution

RESOLUTION NO. 2026-12R

A RESOLUTION OF THE CITY COUNCIL OF THE CITY OF CHICKASHA, GRADY COUNTY, STATE OF OKLAHOMA, AUTHORIZING THE INSTALLATION OF CERTAIN STREETLIGHTS BY AMERICAN ELECTRIC POWER AT SPECIFIED LOCATIONS WITHIN THE CITY; PROVIDING FOR PAYMENT OF THE APPLICABLE MONTHLY CHARGES; AND PROVIDING FOR AN EFFECTIVE DATE.

WHEREAS, the City of Chickasha, Oklahoma (the “City”), is authorized to provide for street lighting within public streets and rights-of-way for the safety and welfare of the public; and

WHEREAS, the City receives electric service for street lighting from American Electric Power, which installs and maintains certain street lighting facilities within the City pursuant to its applicable tariff and service schedules; and

WHEREAS, the City Council has determined that additional street lighting is necessary for public safety and traffic visibility within the Enclave neighborhood of the City; and

WHEREAS, American Electric Power has requested formal authorization from the City Council for the installation of the following streetlights:

1. One (1) 45W Post Top LED Contemporary Streetlight at the corner of W. Mississippi Avenue and S. 35th Street;
2. One (1) 45W Post Top LED Contemporary Streetlight at the corner of S. 35th Street and Enclave Drive;
3. One (1) 45W Post Top LED Contemporary Streetlight at the corner of Enclave Drive and S. 34th Street;
4. One (1) 45W Post Top LED Contemporary Streetlight at the corner of W. Mississippi Avenue and S. 36th Street.

WHEREAS, the City Council finds that the installation of said streetlights will promote the health, safety, and welfare of the residents of the City.

NOW, THEREFORE, BE IT RESOLVED BY THE CITY COUNCIL OF THE CITY OF CHICKASHA, OKLAHOMA:

SECTION 1. Authorization of Streetlights. The City Council hereby authorizes American Electric Power to install the following streetlights within the public rights-of-way of the City of Chickasha:

5. One (1) 45W Post Top LED Contemporary Streetlight at the corner of W. Mississippi Avenue and S. 35th Street;
6. One (1) 45W Post Top LED Contemporary Streetlight at the corner of S. 35th Street and Enclave Drive;

7. One (1) 45W Post Top LED Contemporary Streetlight at the corner of Enclave Drive and S. 34th Street;
8. One (1) 45W Post Top LED Contemporary Streetlight at the corner of W. Mississippi Avenue and S. 36th Street.

SECTION 2. Payment of Charges. The City agrees to pay the applicable monthly streetlight service charges for the above-described fixtures in accordance with the applicable tariff of American Electric Power as approved by the appropriate regulatory authority.

SECTION 3. Administration. The City Manager, or his designee, is hereby authorized to coordinate with American Electric Power for the installation and activation of the streetlights authorized by this Resolution.

This resolution shall be effective immediately.

ADOPTED AND APPROVED this 6th day of April, 2026.

ATTEST:

Zacary Grayson, MAYOR

Susan M. McDaniel, CMC - CITY CLERK
(SEAL)

CHICKASHA

Meeting Type: Council Agenda 4-6-2026

Meeting Date: 4/6/2026

Department: Police Department

Agenda Item No. 6.r.

AGENDA ITEM: Discussion, consideration and possible action to declare certain Animal Welfare Division equipment as surplus, including Maytag washers and dryer, a Fistrend camera system, and an HP computer; waive competitive bidding pursuant to Section 2-219(d) of the City Code; and authorize disposal and transfer to other governmental entities, finding such transfer serves a valid public purpose.

I. BACKGROUND/DESCRIPTION:

The Animal Welfare Division has purchased and installed a Speed Queen commercial grade washer and dryer. The commercial grade equipment replaced old residential models that are no longer in use and need to be surplus. Items needing to be surplus are a Maytag dryer, Model #MEDP586KW0, S/N #MC2004063; a Maytag washer, Model #CB5001134, S/N #MVWP5756GW1 and a Maytag washer, Model #MVWP5756GW0, S/N #C93860401. The Division also has a 6-camera Fistrend wireless camera system and an old HP computer. With Council approval, the computer will go to Industry Systems to be professionally wiped and utilized in a school system. The cameras will go to the Binger Police Department and the washers and dryer will go to the City of Verden Police Department Animal Welfare Division.

II. RECOMMENDED ACTION:

Declare certain Animal Welfare Division equipment as surplus, including Maytag washers and dryer, a Fistrend camera system, and an HP computer; waive competitive bidding pursuant to Section 2-219(d) of the City Code; and authorize disposal and transfer to other governmental entities, finding such transfer serves a valid public purpose.

III. FISCAL INFORMATION -

IV. FUND INFORMATION:

Dept. Director: Goebel Music, #300 Chief of Police	Fund	Account	Amount
	(To)		
	FUND	ACCOUNT	AMOUNT
Meeting Date:	(From)		

04.06.2026		
------------	--	--

V. ATTACHMENTS:

1. Animal Welfare Surplus 4-2026



**Animal Welfare Surplus
04.06.2026**

Item	Make	Model	S/N	Surplus To:
Dryer	Maytag	MEDP586KW0	MC2004063	Verden PD/ACO
Washer	Maytag	CB5001134	MVWP5756GW1	Verden PD/ACO
Washer	Maytag	MVWP5756GW0	C93860401	Verden PD/ACO
Computer	HP	ProDesk 400	2UA5432BPF	Industry Systems
Video Cameras	Firstrend	3.6mm	BK10801-CJJ	Binger PD

Chickasha Police Department

2001 W. Iowa, Chickasha, OK 73018 • (405) 222-6050

The City of Chickasha is an equal opportunity employer and provider. For TDD/TTY assistance, please dial 711.

CHICKASHA

Meeting Type: Council Agenda 4-6-2026

Meeting Date: 4/6/2026

Department: Public Works

Agenda Item No. 6.s.

AGENDA ITEM: Discussion, consideration and possible action to approve an Interlocal Cooperation Agreement for participation in The Oklahoma Purchasing System (TOPS) and authorize the Mayor to execute the agreement.

I. BACKGROUND/DESCRIPTION:

II. RECOMMENDED ACTION:

Approve an Interlocal Cooperation Agreement for participation in The Oklahoma Purchasing System (TOPS) and authorize the Mayor to execute the agreement.

III. FISCAL INFORMATION -

IV. FUND INFORMATION:

Dept. Director: Omar Fierro, Public Works Director	Fund	Account	Amount
	(To)		
	FUND	ACCOUNT	AMOUNT
Meeting Date: April 6, 2026	(From)		

V. ATTACHMENTS:

1. TOPS Membership Flyer
2. TOPS Information
3. The Oklahoma Purchasing System-revision-3

WELCOME TO TOPS!

The Oklahoma Purchasing System connects your agency or company with other agencies or companies for all your procurement needs.

- Free to Join
- No Obligation

www.tops-usa.org

Get in Touch:
info@tops-usa.org

How to Become a Member of TOPS:



Step 1

- Download TOPS Interlocal Agreement Form at <https://tops-usa.org/membership/>
- Seek your Board's Approval

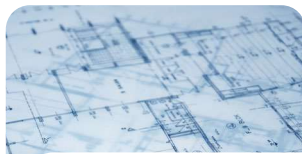
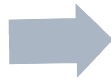

Step 2

- Fill out Agreement
- Email Completed Agreement to info@tops-usa.org for processing



Step 3

- Welcome to TOPS! You will receive an email explaining your next steps.

Contact Us:

David Lassiter

APS Director of TOPS

580-559-9184

david.lassiter@tops-usa.org

Jay McAdams

Director of Business Development

580-775-0768

jay.mcadams@tops-usa.org

Address: 801 S. Greathouse Dr. Atoka, OK 74525

How to Start a Project with TOPS:



Step 1

- Contact a TOPS representative about a Proposed Project
- Project must comply with Oklahoma Statute Title 61



Step 2

- Acquire a Proposal from a TOPS vendor
- TOPS Contract # must be on the proposal



Step 3

- Email the proposal to: compliance@tops-usa.org
- TOPS Compliance Team will review the proposal
- TOPS will issue a verification email if the proposal is compliant



Step 4

- Contract with TOPS Vendor
- Email Proposal - Purchase Order - Contract (As a multi-page PDF) to topspo@tops-usa.org
- TOPS books the compliant project in the database



Step 5

- TOPS Vendor begins work on the Project

Contact Us:

David Lassiter

APS Director of TOPS

580-559-9184

david.lassiter@tops-usa.org

Jay McAdams

Director of Business Development

580-775-0768

jay.mcadams@tops-usa.org

Address: 801 S. Greathouse Dr. Atoka, OK 74525

Scan for more information





Our Mission

The **Oklahoma Purchasing System** is an Interlocal Cooperative in Oklahoma that is ALL OKLAHOMA.

The Oklahoma Purchasing System

TOPS is a Cooperative Purchasing Program established under the Oklahoma Interlocal Cooperation Act, Title 74 O.S. § 1001, et seq.



PROJECTS

All TOPS projects are for maintenance, repair, renovation and remediation of facilities. NO new construction.



COMPLIANCE

TOPS reviews every proposal for compliance on every project.



PRICING

ALL TOPS contractors have provided a discount off of the RS Means unit price book.



PROVEN

TOPS has 100+ projects booked in its first two years of business.

The Facts: TOPS

- TOPS is the only Interlocal Coop in the Nation that awards contracts to the “Lowest Responsible Bidder” and follows ALL bidding requirements found in Title 61.
- TOPS is an option for all entities required to use Title 61 O.S. ~ 101 but it is essential for rural areas of the state that receive very few bids for Title 61 projects.
- Over 95% of TOPS projects are completed by Oklahoma companies or or companies that have a significant presence in Oklahoma.

THE OKLAHOMA PURCHASING SYSTEM

INTERLOCAL COOPERATION AGREEMENT

This Interlocal Cooperation Agreement (also referred to as “Agreement”) is entered into by and between Independent School District No. 15 of Atoka County a/k/a Atoka Public Schools (“APS”) and the member public agencies (“Members”) listed below, pursuant to § 139 of the Oklahoma Public Competitive Bidding Act (“PCBA”), Okla. Stat. tit. 61 § 101, *et seq.*, and the Interlocal Cooperation Act (“the Act”), Okla. Stat. tit. 74, §§ 1001, *et seq.*

MEMBER:

NAME OF AGENCY: _____

BOARD APPROVAL DATE: _____

AGENCY CONTACT: _____

CONTACT TITLE: _____

CONTACT SIGNATURE: _____

APS and Member hereby represent that:

- Both entities are “public agencies,” as that term is defined in the Interlocal Cooperation Act; and
- APS is a public school district, acting under the authority granted to it pursuant to § 139 of the PCBA; and
- Member is a public agency within the State of Oklahoma as defined by 74 O.S. § 1003(A), acting under the authority granted to it pursuant to § 139 of the PCBA; OR
- Member is a public agency outside the State of Oklahoma as defined by 74 O.S. § 1003(A)(5);

NOW THEREFORE, APS and Member hereby agree as follows:

I. DEFINITIONS

For the purposes of this Agreement:

1. The term “public agency” shall mean any political subdivision of the State of Oklahoma or agency of the state government, or public trust, their respective boards, and public trusts of which they are beneficiaries, or a public agency outside the state of Oklahoma;

2. The term “member” shall mean a public agency which has become a party to this Agreement;
3. The term “group” shall mean The Oklahoma Purchasing System;
4. The term “participating agency” shall mean a member or the group;
5. The term “construction-related materials and services” shall mean any materials or services that would or could be required to be subject to public bidding under the PCBA.

II. STATEMENT OF SERVICES OFFERED

APS, as the lead agency for The Oklahoma Purchasing System (TOPS), with BTOK Marketing, LLC as the buyer’s agent, has established and will administer a cooperative purchasing program for construction-related materials and services, and other cooperative contract offerings. Authority for such services is granted by Okla. Stat. tit. 61, § 139.

III. PURPOSE

The purpose of TOPS is to reduce the costs associated with construction-related materials and services, and other cooperative contract offerings at market price, budget control, and to increase construction quality.

IV. TERM

This Agreement covers the period July 1 to June 30 of each calendar year and is good for life unless either party terminates the agreement.

V. RIGHTS

APS, in cooperation with TOPS and BTOK Marketing, LLC, is granted the right to issue a cooperative bid/proposal for construction-related materials and services, and other cooperative contract offerings reflective of the needs supplied by the Members initiating their construction, and other cooperative contract offerings bid/proposal through TOPS. APS, as the lead agency, is further granted the right to secure product award(s) for specific construction-related materials and services, and other cooperative contract offerings for a period of one year in cooperation with TOPS.

VI. DUTIES/RESPONSIBILITIES

APS, as the lead agency is responsible for the following:

- Offer appropriate and necessary support to encourage positive vendor/contractor relationships.
- Distribute this Agreement to potential and current members for adoption or update by their Board of Education.
- Present all Agreements to the APS Board of Education for approval.

TOPS, and BTOK Marketing, LLC, as the buyer's agent, is responsible for the following:

- Provide for the organizational and administrative structure of the program.
- Provide staff time necessary for efficient operation of the program.
- Receive quantity requests from members and prepare appropriate tally of quantities.
- Initiate and implement activities related to the bidding and vendor/contractor selection process in accordance with Oklahoma law, particularly the PCBA.
- Provide members with procedures for ordering, delivery, and billing.

Members are responsible for the following:

- Approving the Interlocal Cooperation Agreement with APS.
- Commit to participate in the program by an authorized signature in the appropriate space within this Agreement.
- Designate a contact person.
- Commit to purchase construction-related materials and services that become part of the official materials and services list when it is in the best interest of the Cooperative Member.
- Prepare purchase orders issued to the appropriate vendor/contractor from the official award list provided by TOPS.
- Accept shipments of products ordered from vendor/contractors in accordance with standard purchasing procedures.
- Pay vendor/contractors in a timely manner for all goods and services received.
- Providing notice of intent to terminate this agreement, in writing, to David Lassiter, Director of TOPS, at least thirty (30) days in advance of the intent to terminate. Advance notice of termination is waived in the event a participating public agency is dissolved or consolidated or a participating school district is consolidated, annexed, designated as fiscally distressed, or managed by the State Department of Education.
- Providing local purchasing estimates to TOPS by the specified deadline for all items to be purchased under contract. The public agency agrees to establish estimates with the intent to purchase said quantities.
- Refraining from initiating bids/proposals for purchasing contracts that conflict with those being solicited by TOPS and for which the Member has enrolled for participation until such time as those solicitations by TOPS are closed.
- Seeking resolution of all problems regarding purchasing, delivery, receiving, and billing, with the appropriate vendor/contractor.

- Understanding and agreeing that participating in this Agreement does not relieve the Members from obligations to comply with all applicable procurement laws.

VII. DISSOLUTION AND DISPOSITION OF PROPERTY

The title to all property, real and personal, acquired by TOPS shall be vested in TOPS. In the event of termination of TOPS, such property shall belong to the then-members of TOPS in pro-rata shares. Upon partial or complete termination of this Agreement, the majority vote of APS’s Board of Education, as the lead agency, shall be binding in all respects as to the disposition of the property and dissolution of TOPS. The APS Board of Education shall serve as trustees for the disposition of property or funds, payment of obligations, dissolution, and winding up of affairs of TOPS.

VIII. FINANCING

The cooperative undertaking in this Agreement shall be financed by requiring vendors/contractors to pay a commission based upon the total value of services and materials provided by such participating vendor/contractor. **No costs shall be incurred by Cooperative Members.**

IX. ACCEPTANCE

APS and the Members who have approved this Agreement enter into this Agreement for cooperative purchasing of construction-related materials and services, and other cooperative contract offerings from any or all awarded contracts in which it chooses to actively participate.

Member Contact Information:

Address: _____
 City: _____
 State: _____ Zip: _____
 Phone: _____ Fax: _____

Primary Contact Name: _____
 Primary Contact Title: _____
 Primary Contact Email: _____
 Primary Contact Phone: _____

Approved by APS Board of Education:

David Lassiter, Director of TOPS

Date

CHICKASHA

Meeting Type: Council Agenda 4-6-2026

Meeting Date: 4/6/2026

Department: Administration

Agenda Item No. 6.t.

AGENDA ITEM: Discussion, consideration and possible action to approve an oil and gas lease with Continental Resources, Inc. following a public auction pursuant to Title 64 Sections 1081 and 1082 for the following described property: An undivided 220.00 acres, more or less, in the N/2 NE/4, S/2 NE/4, SE/4 Section 10, Township 8 North, Range 9 West, Caddo County, Oklahoma

I. BACKGROUND/DESCRIPTION:

II. RECOMMENDED ACTION:

Approve an oil and gas lease with Continental Resources, Inc. following a public auction pursuant to Title 64 Sections 1081 and 1082 for the following described property: An undivided 220.00 acres, more or less, in the N/2 NE/4, S/2 NE/4, SE/4 Section 10, Township 8 North, Range 9 West, Caddo County, Oklahoma

III. FISCAL INFORMATION -

IV. FUND INFORMATION:

Dept. Director:	Fund	Account	Amount
	(To)		
	FUND	ACCOUNT	AMOUNT
Meeting Date: April 6, 2026	(From)		

V. ATTACHMENTS:

1. City Of Chickasha LSE DOCS



JACKFORK LAND
I N C

March 9, 2026

The City of Chickasha, Oklahoma
c/o Zachary Grayson, Mayor
117 N. 4th Street
Chickasha, CO 73018

Re: Oil and Gas Lease with Exhibit
Section 10-08N-09W
Caddo County, Oklahoma

Dear Mineral Owner

Enclosed for execution is an Oil and Gas Lease with Exhibit covering the interest of The City of Chickasha in the aforementioned section. A cursory check of the records indicates that The City of Chickasha may own **220.00 Net Mineral Acres (nma)** and that you have agreed to the bonus consideration of **\$1,700.00/nma** for a possible total bonus consideration due of **\$374,000.00**. A copy of the lease documents has been included for your records.

Please execute the lease documents in the following manner:

1. Please sign the lease and exhibit in the spaces indicated **exactly as they have been typed being sure your signature on the lease is witnessed by a Notary Public.** If there are any changes, please make them and initial each alteration.
2. Complete and sign the enclosed W-9 form where indicated, being sure to enter the Tax ID Number for The City of Chickasha, Oklahoma in the space marked. This form must be returned before payment can be made.
3. Please return the signed and notarized **original lease, exhibit and W-9** to our office at **Jackfork Land, Inc., 925 Cedar Lake Blvd., Oklahoma City, OK 73114-7813** for processing. Payment is to be made by check once your mineral interest has been verified. ***(If you would like your check and 1099 sent to an address other than what is stated on your lease please provide alternative address on separate note.)***

This offer is subject to Continental Resources, Inc.'s approval of marketable title. This offer to lease is valid for a period of 14 days from the receipt of the enclosed lease documents. Failure to return the requested documents to our office within the 14 day period may result in the withdrawal of this offer to lease.

Thank you for your timely attention to this matter. Should you have any questions, or if I may be of any assistance, please do not hesitate to contact our office.

As explained above, if the lease documents are not returned to our office or postmarked within 14 days of receipt, this offer may be withdrawn.

Sincerely,

Steven Welch

Steven Welch, Agent

SW/mg
Enclosures

OIL AND GAS LEASE

(Paid-up)

AGREEMENT, made and entered into this 6th day of March, 2026, by and between **The City of Chickasha, Oklahoma, a municipal Corporation of the State of Oklahoma**, 117 N. 4th Street, Chickasha, OK 73018, party of the first part, hereinafter called Lessor (whether one or more), and **Continental Resources, Inc.**, with a mailing address of 20 North Broadway, Oklahoma City, OK 73102, party of the second part, hereinafter called Lessee.

WITNESSETH, that the said Lessor, for and in consideration of Ten Dollars, cash in hand paid, and other good and valuable consideration, the receipt of which is hereby acknowledged and of the covenants and agreements hereinafter contained on the part of Lessee to be paid, kept and performed, has granted, demised, leased and let and by these presents does grant, demise, lease and let unto the said Lessee, for the sole and only purpose of exploring by geophysical and other methods, mining and operating for oil (including but not limited to distillate and condensate), gas (including casinghead gas and helium and all other constituents), and for laying pipelines, and building tanks, power stations and structures thereon, to produce, save and take care of said products, all that certain tract of land, together with any reversionary rights therein, situated in the County of **Caddo**, State of Oklahoma, described as follows, to-wit:

An undivided 220.00 acres, more or less, in the N/2 NE/4, S/2 NE/4, SE/4 Section 10, Township 8 North, Range 9 West, Caddo County, Oklahoma

See Exhibit "A" attached hereto and made a part hereof.

1. It is agreed that this lease shall remain in force for a term of three (3) years from date (herein called primary term) and so long thereafter as oil or gas, or either of them, is produced from said land by the Lessee.

2. In consideration of the premises the said Lessee covenants and agrees:

A. To deliver to the credit of Lessor free of cost, in the pipeline to which it may connect its wells, a one-fifth (1/5) part of all oil and gas (including but not limited to condensate and distillate) produced and saved from the leased premises.

B. During any period (whether before or after expiration of the primary term hereof) when gas is not being so sold or used and the well or wells are shut in and there is no current production of oil or operations on said leased premises sufficient to keep this lease in force, Lessee shall pay or tender a royalty of One Dollar (\$1.00) per year per net royalty acre retained hereunder, such payment or tender to be made, on or before the later of ninety (90) days following the date of shut in or the anniversary date of this lease during the period such well is shut in, to the Lessor. When such payment or tender is made it will be considered that gas is being produced within the meaning of the entire lease.

3. If, at the expiration of the primary term, there is no production in paying quantities on the leased land or on lands pooled therewith but Lessee is conducting operations for drilling, completing or reworking a well, this lease nevertheless shall continue as long as such operations are prosecuted or additional operations are commenced and prosecuted (whether on the same or successive wells) with no cessation of more than ninety (90) days, and if production is discovered, this lease shall continue as long thereafter as oil or gas are produced. In addition, if at any time or times after the primary term, there is a total cessation of all production, for any cause (other than an event of force majeure), this lease shall not terminate if Lessee commences or resumes any drilling or reworking operations or production within ninety (90) days after such cessation. For purposes of extending this Lease beyond the primary term, 'operations' shall mean actual on-site drilling or reworking activities conducted with a drilling rig capable of reaching total depth. Preparatory activities, including but not limited to staking, surveying, grading, constructing roads or locations,

mobilizing materials or equipment, or placing any item or structure on the premises shall not constitute operations for purposes of maintaining this Lease in force

4. Lessee is hereby granted the right at any time and from time to time to unitize the leased premises or any portion or portions thereof, as to all strata or any stratum or strata, with any other lands as to all strata or any stratum or strata, for the production primarily of oil or primarily of gas with or without distillate. However, no unit for the production primarily of oil shall embrace more than 160 acres, or for the production primarily of gas with or without distillate more than 640 acres; provided that if any governmental regulation shall permit or prescribe a spacing pattern for the development of the field or allocate a producing allowable based on acreage per well, then any such unit may embrace as much additional acreage as may be so permitted or prescribed or as may be used in such allocation of allowable. Lessee shall file written unit designations in the county in which the leased premises are located unless the pooling or unitization results from governmental order or rule, in which case no such written designation shall be required. Operations upon and production from the unit shall be treated as if such operations were upon or such production were from the leased premises whether or not the well or wells are located thereon. The entire acreage within a unit shall be treated for all purposes as if it were covered by and included in this lease except that the royalty on production from the unit shall be as below provided, and except that in calculating the amount of any shut in gas royalties, only the part of the acreage originally leased and then actually embraced by this lease shall be counted. In respect to production from the unit, Lessee shall pay Lessor, in lieu of other royalties thereon, only such proportion of the royalties stipulated herein as the amount of his acreage placed in the unit, or his royalty interest therein on an acreage basis bears to the total acreage in the unit.

5. If said Lessor owns a less interest in the above described land than the entire and undivided fee simple estate therein, then the royalties herein provided shall be paid to the Lessor only in the proportion which his interest bears to the whole and undivided fee.

6. Lessee shall have the right to use, free of cost, gas, oil, and produced on said land for its operations thereon, except water from the leased premises.

7. Lessee shall have the right at any time to remove all machinery and fixtures placed on said premises, including the right to draw and remove casing.

8. If the estate of either party hereto is assigned, and the privilege of assigning in whole or in part is expressly allowed, the covenants hereof shall extend to their heirs, executors, administrators, successors or assigns. However, no change or division in ownership of the land or royalties shall enlarge the obligations or diminish the rights of Lessee. No change in the ownership of the land or royalties shall be binding on the Lessee until after the Lessee has been furnished with a written transfer or assignment or a true copy thereof. In case Lessee assigns this lease, in whole or in part, lessee shall be relieved of all obligations with respect to the assigned portion or portions arising subsequent to the date of assignment.

9. All express or implied covenants of this lease shall be subject to all Federal and State Laws, Executive Orders, Rules and Regulations, and this lease shall not be terminated, in whole or in part, nor Lessee held liable in damages, for failure to comply therewith, if compliance is prevented by, or such failure is the result of any such Law, Order, Rule or Regulation, or operation of force majeure.

10. This lease shall be effective as to Lessor on execution hereof and shall be binding on those signing, notwithstanding some of the Lessors above named may not join in the execution hereof. The word "Lessor" as used in this lease means the party or parties who execute this lease as Lessor, although not named above.

11. Lessor does not guarantee or warrant title to the above described properties. In the event of failure of title, Lessor shall not be required to refund any bonuses, royalties, shut-in payments or other considerations paid to lessors.

12. Lessee may at any time and from time to time surrender this lease as to any part or parts of the leased premises by delivering or mailing a release thereof to lessor, or by placing a release of record in the proper County.

13. Lessee shall pay for all damages to land and crops caused by its operations. No well shall be drilled nearer than 200 feet to any house or barn now on said premises, without the written consent of the Lessor.

14. The Lessee's failure to comply with any covenant or obligation of this lease shall not result in the forfeiture of the lease unless and until lessor has provided lessee notice of such default and gives Lessee sixty (60) days in which to cure such default.

15. Before commencing any operations on lands where Lessor is the owner of the surface Lessee shall obtain from Lessor, by written agreement, permission to use that certain portion of said lands set out in the written agreement for drill site and to conduct mining and drilling operations or the production, storage, or removal of minerals therefrom.

16. This Lease is subject to and fully includes each and every provision as provided on Exhibit

IN TESTIMONY WHEREOF, we sign this _____ day of _____, 2026.

ATTEST:

The City of Chickasha, Oklahoma,
a municipal Corporation of the State of Oklahoma

CITY CLERK

By: _____
MAYOR

ACKNOWLEDGMENT

STATE OF OKLAHOMA)
COUNTY OF GRADY) SS:

Before me, in and for said county and State, on this ____ day of _____, 2026, personally appeared Zachary Grayson, to me known to be the identical person who subscribed the name of the maker thereof to the foregoing instrument as the Mayor of The City of Chickasha, Oklahoma, a municipal Corporation of the State of Oklahoma, and acknowledged before me that he executed the same as his free and voluntary act and deed, and as the free and voluntary act and deed of such municipal corporation, for the uses and purposes therein set forth.

My Commission Expires: _____

Notary Public

Commission No.: _____

EXHIBIT "A"

Attached to and made a part of that certain Oil and Gas Lease dated the 6th day of March, 2026, between **The City of Chickasha, a municipal corporation, of the State of Oklahoma**, as Lessor and **Continental Resources, Inc.**, with a mailing address of 20 North Broadway, Oklahoma City, OK 73102, as Lessee. Said addendum and additional provisions relate to the following tract of property:

An undivided 220.00 acres, more or less, in the N/2 NE/4, S/2 NE/4, SE/4 Section 10, Township 8 North, Range 9 West, Caddo County, Oklahoma

- 1) Notwithstanding anything herein above to the contrary, it is expressly provided that the provisions of the following paragraphs shall prevail in the event of the conflict with any provisions in the preceding printed form Oil and Gas Lease.
- 2) Notwithstanding anything to the contrary contained herein, upon expiration of the primary term of this lease, this lease shall automatically terminate and expire as to all leasehold rights below 100 feet below the stratigraphic equivalent of the deepest common source of supply penetrated in any well, spud after the date of this lease, on lands covered by this lease or on lands with which lands covered by this lease are spaced by order of the Oklahoma Corporation Commission or voluntarily unitized therewith. Provided, however, if within the primary term of this lease, lessee should commence operations to drill, deepen, or rework a well under the terms of this lease, the lessee shall have the right to drill such well to completion and/or continue deepening and/or complete reworking operations with reasonable diligence and dispatch, and if oil and gas be found in paying quantities, this lease shall terminate only to the depth provided in this clause.
- 3) Notwithstanding anything to the contrary contained herein, it is expressly agreed that the completion of a well capable of production in paying quantities on a drilling and spacing unit(s), established by any governmental authority or agency shall extend beyond the primary terms only that portion of the leased premises contained within said drilling and spacing unit(s), and that, subject to the provisions of this paragraph, the portion of the leased premises outside the said drilling and spacing unit(s) shall be released at the expiration of the primary term. Provided, however, that if within the primary term of this Lease, Lessee shall commence operations to drill or rework a well under the terms of this Lease, the Lessee shall have the right to drill such a well to completion and/or complete reworking operations with reasonable diligence and dispatch, and if oil or gas be found in paying quantities, this Lease shall terminate only to those lands lying outside of said drilling and spacing units(s). If a "unit" has not been established by any state regulatory agency of the State of Oklahoma, or under the pooling clause of this lease, "unit" shall be deemed for all purposes to comprise the governmental quarter/quarter/quarter section (10 Acres) upon which the borehole of any well drilled pursuant to this lease is actually located.
- 4) There shall be no salt water disposal on the above-described real property.
- 5) Lessee shall indemnify and hold Lessor harmless from any and all liability, liens, demands, judgments, suits, and claims of any kind or character arising out of, in connection with, or relating to Lessee's operations under the terms of this Lease, including, but not limited to, claims for injury to or death of any persons, or damage, loss or destruction of any property, real or personal, under any theory of tort, contract, or strict liability. Lessee's obligations under this paragraph shall survive termination, release or expiration of the Lease.
- 6) Lessee shall, at its sole cost and expense, promptly remediate, clean up, and restore any soil, surface, subsurface, groundwater, vegetation, or improvements that are impacted, contaminated, or damaged as a result of Lessee's operations under this Lease. Such remediation shall be conducted in compliance with all applicable federal, state, and local laws, rules, and regulations, and to the satisfaction of the Lessor. Lessee's obligations under this paragraph shall

survive termination, release or expiration of the Lease, and shall not be limited by the Oklahoma Surface Damages Act or any monetary compensation paid thereunder.

7) Notwithstanding anything to the contrary contained herein, after the expiration of the primary term of this lease, shut-in royalty payments shall be restricted to maintain this lease in force for a maximum of two (2) years for each shut-in period. Notwithstanding the foregoing, in no event shall cumulative shut-in royalty payments, whether from one or multiple shut-in periods, maintain this Lease for more than three (3) years total.

8) The use of the above described property by Lessee is limited only to producing wells physically located on said premises. Tank batteries and other applicable equipment shall not be located hereon, except for wells actually located on the leased premises. Pipelines and roads across the leased premises are limited to those wells located on the leased premises and only after payment of damages as determined by the parties.

9) Notwithstanding anything herein to the contrary, Lessee shall pay royalty on the fair market value received at the point of sale, with an arms length transaction, without any post production expenses or costs being prorated back to Lessor. Such post production expenses/costs are to include, but are not limited to, the cost of producing, gathering, storing, separating, treating, dehydrating, compressing, processing, manufacturing, transporting, and marketing the oil and/or gas produced hereunder whether the point of sale is at or off the leased premises. Such royalty is to include all oil, gas; including all its constituents and any other by-products produced and saved from the leased premises.

10) It is specifically understood by Lessee that any operations of the Leased Premises by the Lessee shall be in accordance with the laws and statutes of the State of Oklahoma and the Ordinances of the City of Chickasha, the rules and regulations of any other state or Federal regulatory agency. It is further understood that if the Leased Premises are a part of the municipal airport of the City of Chickasha, then the rules and regulations of the Federal Aviation Administration and the Ordinances of the City of Chickasha shall govern the location of the drill site, and any drilling operations thereon.

11) Lessee agrees that substantiation and validation of this lease is at the sole discretion and obligation of the Lessee and if lease is rendered invalid for any reason, save typographical error, including names or descriptions, Lessor shall not be required to refund any rents, royalties, bonuses, shut-in payments or other considerations paid.

12) Surface damages arising from Lessee's operations shall be negotiated separately from this Lease. If the parties cannot agree upon an amount of surface damages, Lessee shall take such action as is necessary pursuant to the Oklahoma Surface Damages Act, 52 O.S. § 318.2 et seq.

Lessee's obligation to compensate Lessor for surface damages under this paragraph shall not relieve Lessee of any liability to any lawful surface tenant for actual crop loss or interference with surface use caused by Lessee's operations.

13) It is expressly understood and agreed that the City of Chickasha makes no guarantee, representation, or warranty, express or implied, as to the validity, sufficiency, or marketability of its title to any of the properties described herein. The City of Chickasha further disclaims any warranty that the mineral interests covered by this Lease are unencumbered or unleased. In the event any title defect is discovered, or if the mineral interests are determined to be subject to a pre-existing lease, encumbrance, or other adverse claim, the Lessee shall not be entitled to any refund, reimbursement, or other compensation from the City of Chickasha for any consideration paid, including but not limited to bonuses, rentals, royalties, shut-in payments, damages, or other sums.

ACKNOWLEDGEMENT PAGE TO FOLLOW

SIGNED FOR IDENTIFICATION:

LESSOR: The City of Chickasha, Oklahoma
a municipal Corporation of the State of Oklahoma

By: _____
MAYOR

ATTEST:

CITY CLERK

ACKNOWLEDGMENT

STATE OF OKLAHOMA)
COUNTY OF GRADY) SS:

Before me, in and for said county and State, on this ____ day of _____, 2026, personally appeared Zachary Grayson, to me known to be the identical person who subscribed the name of the maker thereof to the foregoing instrument as the Mayor of The City of Chickasha, Oklahoma, a municipal Corporation of the State of Oklahoma, and acknowledged before me that he executed the same as his free and voluntary act and deed, and as the free and voluntary act and deed of such municipal corporation, for the uses and purposes therein set forth.

My Commission Expires: _____

Notary Public

Commission No.: _____

CHICKASHA

Meeting Type: Council Agenda 4-6-2026

Meeting Date: 4/6/2026

Department: Administration

Agenda Item No. 6.u.

AGENDA ITEM: Discussion, consideration, and possible action to approve temporary street closure of the 100 block of Chickasha Avenue for the monthly held Coffee & Cars Downtown on the last Saturday of each month of 2026 and waive any associated fees.

I. BACKGROUND/DESCRIPTION:

Indemnification Agreement and Certificate of Liability Insurance will be in place for each event.

II. RECOMMENDED ACTION:

Approve temporary street closure of the 100 block of Chickasha Avenue for the monthly held Coffee & Cars Downtown on the last Saturday of each month of 2026 and waive any associated fees.

III. FISCAL INFORMATION -

IV. FUND INFORMATION:

Dept. Director: Susan M. McDaniel, CMC City Clerk	Fund	Account	Amount
	(To)		
	FUND	ACCOUNT	AMOUNT
Meeting Date: April 6, 2026	(From)		

V. ATTACHMENTS:

- 20260401105836793

COFFEE & CARS DOWN TOWN

My name is Brandi Terry, representing Brandis Bar & Grill. In partnership with Patrick Reiss of Coffee & Cars Downtown, we are collaborating to support the downtown community.

Patrick and I have discussed the continued growth of Coffee & Cars Downtown. The event is scheduled for the last Saturday of each month from 7:00 a.m. to 12:00 p.m. We respectfully request the city's permission to close the 100 block and horseshoe area during these hours. We will provide our own barricades and ensure no conflicts with other scheduled downtown events.

Our goal is to contribute to downtown revitalization. Organized events like these help create a vibrant downtown atmosphere. We encourage the inclusion of vendors offering engaging activities for children, providing families with free and enjoyable options.

We would welcome any guidance or feedback the city may offer to help ensure the continued success and growth of downtown.

We have spoken with Cheryl from the EDC, and she has told us that our dates and times will not conflict with the EDC's downtown events.

We are asking for

4-25-26

5-30-26

6-27-26

7-25-26

8-29-26

9-26-26

10-31-26

11-28-26

12-26-31

Sincerely,

Brandi Terry 405-820-9081 ✓

&

Patrick Reiss 405-202-8587

Coffee and Cars events are vital for small towns, bringing car enthusiasts together to display vehicles and socialize over coffee. Held downtown on weekend mornings, they create a lively atmosphere that strengthens community ties and attracts locals and visitors alike.

History

The concept took off in the early 2000s, notably with Southern California's "Cars and Coffee." However, informal car gatherings over coffee at diners and cafes have a longer tradition, one that small towns have adopted for its community value.

Why It Helps Small Towns

1. Community Building:

Coffee and Cars events foster community by uniting people of all ages around a shared interest. Car owners connect through stories and passion, while residents enjoy an accessible, engaging gathering that strengthens neighborhood bonds.

2. Economic Boost:

Local businesses, including coffee shops, diners, and boutiques, experience an economic lift as more people visit, shop, and dine during the event, directly boosting sales and increasing the area's commercial activity.

3. Revitalization of Downtown:

By regularly drawing crowds, these gatherings make downtown areas more attractive and vibrant, encouraging ongoing investment and reducing the underuse of these central spaces.

4. Tourism and Exposure:

Enthusiasts from other towns visit, boosting the town's visibility and potential return visits, thereby enhancing tourism and local recognition.

5. Family-Friendly Entertainment:

Coffee and Cars provides an accessible, safe event the whole family can enjoy, promoting a lively downtown and encouraging regular participation from residents of all ages.

Conclusion

The tradition of gathering for Coffee and Cars in small-town downtowns is more than a car show—it is a powerful driver of community connection, economic growth, and local culture. By pairing classic automobiles with the universal appeal of coffee, these events help make small-town centers more vibrant and resilient.

history of how coffee and cars downtown help the growth of small

The 'Coffee and Cars' tradition—where car enthusiasts and residents gather in downtown areas to display vehicles and connect over coffee—serves as a significant catalyst for the revitalization and growth of small towns.

How It Helps the Growth of Small Towns

1. Boosts Local Economy:

Coffee and Cars events bring more residents and visitors downtown, benefiting local shops, restaurants, and retailers with increased foot traffic and sales.

2. Revitalizes Downtown Areas:

These events bring new energy to downtown areas on weekend mornings, re-establishing these spaces as vibrant community centers through a lively, welcoming atmosphere.

3. Promotes Community Engagement:

Coffee and Cars bring people from all walks of life together. It encourages socializing, networking, and community pride, which in turn helps foster a sense of belonging and investment in the town's future.

4. Attracts Tourism and New Residents:

By offering unique gatherings like Coffee and Cars, small towns attract visitors and can inspire them to consider investing in the community.

5. Showcases Local Culture and Talent:

These gatherings often highlight local music, art, and food, providing a platform for small-town talent and boosting cultural life.

Conclusion

By uniting a love for cars and morning coffee, Coffee and Cars gatherings serve as strategic tools for supporting local business, strengthening community bonds, and driving small-town growth—proving that simple traditions can empower economic and cultural renewal.

history of coffee and cars downtown, and how it helps small towns and businesses

This expanded version provides historical context for how Coffee and Cars events originated in small-town downtowns and details specific ways these gatherings support small towns and local businesses economically, culturally, and as a community.



CERTIFICATE OF LIABILITY INSURANCE

DATE (MM/DD/YYYY)
02/20/2026

THIS CERTIFICATE IS ISSUED AS A MATTER OF INFORMATION ONLY AND CONFERS NO RIGHTS UPON THE CERTIFICATE HOLDER. THIS CERTIFICATE DOES NOT AFFIRMATIVELY OR NEGATIVELY AMEND, EXTEND OR ALTER THE COVERAGE AFFORDED BY THE POLICIES BELOW. THIS CERTIFICATE OF INSURANCE DOES NOT CONSTITUTE A CONTRACT BETWEEN THE ISSUING INSURER(S), AUTHORIZED REPRESENTATIVE OR PRODUCER, AND THE CERTIFICATE HOLDER.

IMPORTANT: If the certificate holder is an ADDITIONAL INSURED, the policy(ies) must have ADDITIONAL INSURED provisions or be endorsed. If SUBROGATION IS WAIVED, subject to the terms and conditions of the policy, certain policies may require an endorsement. A statement on this certificate does not confer rights to the certificate holder in lieu of such endorsement(s).

PRODUCER Graham-Rogers, Inc 501 SE Frank Phillips Blvd Bartlesville OK 74003		CONTACT NAME: PHONE (A/C, No, Ext): (800) 456-8123 E-MAIL ADDRESS: FAX (A/C, No):	
INSURED Brandi's Grill LLC 2282 CS 2814 Chickasha OK 73018		INSURER(S) AFFORDING COVERAGE INSURER A: Western World Insurance Company INSURER B: INSURER C: INSURER D: INSURER E: INSURER F:	
		NAIC # 13196	

COVERAGES **CERTIFICATE NUMBER:** **REVISION NUMBER:**

THIS IS TO CERTIFY THAT THE POLICIES OF INSURANCE LISTED BELOW HAVE BEEN ISSUED TO THE INSURED NAMED ABOVE FOR THE POLICY PERIOD INDICATED. NOTWITHSTANDING ANY REQUIREMENT, TERM OR CONDITION OF ANY CONTRACT OR OTHER DOCUMENT WITH RESPECT TO WHICH THIS CERTIFICATE MAY BE ISSUED OR MAY PERTAIN, THE INSURANCE AFFORDED BY THE POLICIES DESCRIBED HEREIN IS SUBJECT TO ALL THE TERMS, EXCLUSIONS AND CONDITIONS OF SUCH POLICIES. LIMITS SHOWN MAY HAVE BEEN REDUCED BY PAID CLAIMS.

INSR LTR	TYPE OF INSURANCE	ADDL INSD	SUBR WVD	POLICY NUMBER	POLICY EFF (MM/DD/YYYY)	POLICY EXP (MM/DD/YYYY)	LIMITS
A	<input checked="" type="checkbox"/> COMMERCIAL GENERAL LIABILITY <input type="checkbox"/> CLAIMS-MADE <input checked="" type="checkbox"/> OCCUR GEN'L AGGREGATE LIMIT APPLIES PER: <input checked="" type="checkbox"/> POLICY <input type="checkbox"/> PRO-JECT <input type="checkbox"/> LOC OTHER:			NPP6210968	08/21/2025	08/21/2026	EACH OCCURRENCE \$ 1,000,000 DAMAGE TO RENTED PREMISES (Ea occurrence) \$ 100,000 MED EXP (Any one person) \$ 5,000 PERSONAL & ADV INJURY \$ 1,000,000 GENERAL AGGREGATE \$ 2,000,000 PRODUCTS - COMP/OP AGG \$ 1,000,000 \$
	AUTOMOBILE LIABILITY <input type="checkbox"/> ANY AUTO <input type="checkbox"/> ALL OWNED AUTOS <input type="checkbox"/> SCHEDULED AUTOS <input type="checkbox"/> HIRED AUTOS <input type="checkbox"/> NON-OWNED AUTOS						COMBINED SINGLE LIMIT (Ea accident) \$ BODILY INJURY (Per person) \$ BODILY INJURY (Per accident) \$ PROPERTY DAMAGE (Per accident) \$ \$
	<input type="checkbox"/> UMBRELLA LIAB <input type="checkbox"/> OCCUR <input type="checkbox"/> EXCESS LIAB <input type="checkbox"/> CLAIMS-MADE DED RETENTION \$						EACH OCCURRENCE \$ AGGREGATE \$ \$
	WORKERS COMPENSATION AND EMPLOYERS' LIABILITY ANY PROPRIETOR/PARTNER/EXECUTIVE OFFICER/MEMBER EXCLUDED? (Mandatory in NH) If yes, describe under DESCRIPTION OF OPERATIONS below		Y/N N/A				<input type="checkbox"/> PER STATUTE <input type="checkbox"/> OTH-ER E.L. EACH ACCIDENT \$ E.L. DISEASE - EA EMPLOYEE \$ E.L. DISEASE - POLICY LIMIT \$
C	Liquor Liability			LQ 2013888A	07/26/2025	07/26/2026	500,000/1,000,000

DESCRIPTION OF OPERATIONS / LOCATIONS / VEHICLES (ACORD 101, Additional Remarks Schedule, may be attached if more space is required)
Restaurant
\$250 BI/PD Deductible

CERTIFICATE HOLDER CITY OF CHICKASHA 117 N. 4TH STREET CHICKASHA OK 73018	CANCELLATION SHOULD ANY OF THE ABOVE DESCRIBED POLICIES BE CANCELLED BEFORE THE EXPIRATION DATE THEREOF, NOTICE WILL BE DELIVERED IN ACCORDANCE WITH THE POLICY PROVISIONS. AUTHORIZED REPRESENTATIVE 
---------------------------------------------------------------------------------------------------	-----------------------------------------------------------------------------------------------------------------------------------------------------------------------------------------------------------------------------------------------------------------------------------------------------------------

CHICKASHA

COMMUNITY DEVELOPMENT

OUTDOOR AMUSEMENT EVENT LICENSE APPLICATION

Date: 3-12-20 Event Date(s) & Times: 7am - 12 pm

Event Type (Include a description of all events and functions): LAST Sat of every month when there is nothing on the 100 Block Coffee + Cardio

Applicant: Brancki Terry / Patrick Reiss

Mailing Address: 101 W. Chickasha Ave
 City: Chickasha State: OK Zip: 73018

Event Address or location description: 100 Block

Property Owner: Brancki Terry Phone Number: 405-870-9081

Mailing Address: 101 W. Chickasha Ave
 City: Chickasha State: OK Zip: 73018

Present Zoning District: _____ Size of Event Space (Acres): _____

Type of Sanitary Facilities to be Provided: Branckis, Flowershop, Lady Hoop + Ralph

Type of Solid Waste Facilities to be Provided: trash can +

Combined Estimated Number of Participants/Spector's: NOT SURE

Describe Parking Facilities to be Provided (Including surface type, access and number of spaces): Behind DHS, side of Branckis, side of Lady Hoop

REQUIREMENTS.

Advertising Signs: NO Off-Premises Advertising Signs shall be allowed.

Comments:

- Reviewed By: _____ Police Department _____
- Reviewed By: _____ Fire Department _____
- Reviewed By: _____ Public Works _____
- Reviewed By: _____ Community Development _____
- Approved Denied By: _____ City Manager's Office

CHICKASHA

Meeting Type: Council Agenda 4-6-2026

Meeting Date: 4/6/2026

Department: Administration

Agenda Item No. 6.v.

AGENDA ITEM: Discussion, consideration, and possible action to approve the request from the Chickasha Youth Baseball to use the Sports Complex for the Spring 2026 Season and waive any associated fees.

I. BACKGROUND/DESCRIPTION:

See attached letter of request.

II. RECOMMENDED ACTION:

Discussion, consideration, and possible action to approve the request from the Chickasha Youth Baseball to use the Sports Complex for the Spring 2026 Season and waive any associated fees.

III. FISCAL INFORMATION -

IV. FUND INFORMATION:

Dept. Director:	Fund	Account	Amount
	(To)		
	FUND	ACCOUNT	AMOUNT
Meeting Date: April 6, 2026	(From)		

V. ATTACHMENTS:

- 20260401123824995

March 6, 2026

RE: Request for Use of Chickasha Sports Complex – Spring 2026 Season

Dear Mayor Zachary Grayson,

Chickasha Youth Baseball is a nonprofit 501(c)(3) organization registered with the IRS and the Oklahoma Secretary of State. We respectfully request the use of the Chickasha Sports Complex from March 1, 2026, through June 30, 2026, and ask that the associated usage fees be waived.

Our organization provides children from Chickasha and the surrounding communities the opportunity to participate in competitive baseball through the OK Kids Baseball Association and competitive softball through the South Central Girls Softball League, with games played locally at the Chickasha Sports Complex. Offering these programs within our community positively impacts the lives of local families by providing a healthy, structured, and active environment for area youth.

In past seasons, Chickasha Youth Baseball has invested in the complex by purchasing pitching mounds, installing sod, and spraying the fields for weeds. We value the strong working relationship we have established with the City and are committed to continuing our efforts to help maintain and improve the facilities for the benefit of our community's children.

We respectfully request approval for use of the Chickasha Sports Complex for practices and games during the 2026 spring season. We sincerely appreciate your consideration and look forward to another successful season of baseball and softball in Chickasha.

Thank you for your time and continued support of our youth.

Sincerely,

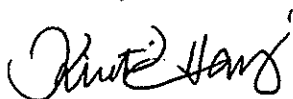

Dusty Venable, Kristi Harris, and Cale Walker on behalf of Chickasha Youth Baseball & Softball

Susan McDaniel, CMC

From: Kristi Harris <chickashayouthbaseball@gmail.com>
Sent: Monday, March 9, 2026 1:45 PM
To: Zachary Grayson; Susan McDaniel, CMC; Omar Fierro
Subject: Use of Sports Complex
Attachments: Use of Sports Complex for Chickasha Youth Baseball and Softball.pdf

Good afternoon all. I have attached our letter to be added to the next agenda.

Please let me know if you have any questions or need anything further from us.

Thank you.

Kristi Harris