

CHICKASHA MUNICIPAL AUTHORITY

AGENDA
LOCATION OF MEETING
CITY HALL COUNCIL CHAMBERS
117 NORTH FOURTH STREET
CHICKASHA, OKLAHOMA 73018

TIME OF MEETING
6:30 PM

DATE OF MEETING
MAY 4, 2026

All items on this agenda, including but not limited to any agenda item concerning the adoption of any ordinance, resolution, contract, agreement, or any other item of business, are subject to amendment, including additions and/or deletions. This rule will apply to every individual agenda item without exception, and without providing this same amendment language with respect to each individual agenda item. Such amendments should be rationally related to the topic of the agenda item, or the governing body will be advised to continue the item.

The governing body may adopt, approve, ratify, deny, defer, recommend, amend, strike, or continue any agenda item. When more information is needed to act on an item, the governing body may refer the matter to its City/Trust Manager, staff, attorney or to the recommending board, commission or committee.

- 1. Call to Order / Roll Call.**

- 2. Consent Docket:**
 - a. Acceptance of the Minutes of the April 20, 2026, regular meeting.
 - b. Acceptance of the Claims List.
 - c. Accept and ratify action to engage HSPG & Associates, LLC to perform the City of Chickasha's audit services for FY25 and FY 26 and authorize Chairman to execute the same.

- 3. Discussion/Approval of Items Removed from Consent Docket:**

- 4. Consideration and Discussion Items:**

- a. Discussion, consideration, and possible action to authorize the Chairman to execute a Task Order with WSB Engineering under the existing Master Service Agreement for Congo Creek Basin #1 – Drainage Design in the amount of \$117,545.00.
- b. Discussion, consideration and possible action to authorize the purchase of a 2026 Ram 2500 Crew Tradesman 4x4 Truck using State Contract SW0035M in the amount of \$47,123.00.
- c. Discussion, consideration, and possible action to authorize the Trust Manager and Chairman to execute all necessary documents to support submission of an application under the Oklahoma Disaster Mitigation and Recovery Matching Fund Program (ODMRMF) through the Association of South Central Oklahoma Governments (ASCOG), requesting \$1,687,630 to satisfy the required local match for the BRIC grant-funded design phase of the Line Creek Flood Mitigation Project.
- d. Discussion, consideration, and possible action to approve a License Agreement between the Chickasha Municipal Authority and Stillwater Central Railroad, L.L.C. for an underground pipeline crossing and existing waterline facilities within railroad right-of-way in connection with the Authority's water system improvements project, including approval of associated fees, and authorization of the Chairman to execute the agreement.
- e. Discussion, consideration, and possible action to approve a Contract Amendment Between Fort Cobb Reservoir Master Conservancy District and the Chickasha Municipal Authority, Chickasha, Oklahoma to Extend the May 14, 1992, Contract for an Additional 5-Year Term and authorize the Chairman to execute the same.

5. Motion for Adjournment.

CHICKASHA

Meeting Type: CMA Agenda 5-4-2026

Meeting Date: 5/4/2026

Department: City Clerk

Agenda Item No. 2.a.

AGENDA ITEM: Acceptance of the Minutes of the April 20, 2026, regular meeting.

I. BACKGROUND/DESCRIPTION:

II. RECOMMENDED ACTION:

III. FISCAL INFORMATION -

IV. FUND INFORMATION:

	Fund	Account	Amount
Dept. Director: Susan M. McDaniel, CMC - City Clerk	(To)		
	FUND	ACCOUNT	AMOUNT
Meeting Date: May 4, 2026	(From)		

V. ATTACHMENTS:

1. CMA 4-20-2026

April 20, 2026

The **REGULAR** meeting of the **CHICKASHA MUNICIPAL AUTHORITY** was held in the council chambers in city hall on the 20th day of April 2026 as specified by advance public notice with a properly prepared agenda stating the subject matter or matters to be discussed at said meeting. Chairman Grayson called the meeting to order at 7:06 p.m.

ITEM 1. **Call to Order / Roll Call:**

CHAIRMAN AND TRUSTEES

PRESENT: Zachary Grayson, Chairman
Georgianne Hebblethwaite, Vice Chairman
Lisa Hatchett
Kim Irving
Kea Ginn
Kelly Boyd
Erica Alexander
Rockey Talley
Clark Southard

ABSENT: None.

STAFF

PRESENT: Jim Crosby, City Manager
Amanda Mullins, City Attorney
Susan M. McDaniel, City Clerk
G. Music, Police Chief
Tony Samaniego, Fire Chief
Lillie Huckaby, Library Director
Rich Edwards, Finance Direct
Jessica Green, Community Development Director
Omar Fierro, Public Works Director
Andy Conyers, Parks & Rec Director
Omar Fierro, Public Works Director
Tracey Austin, HR Director

ITEM 2. **Consent Docket: ITEM 2a – ITEM 2c.**

ITEM 2a. **Acceptance of the Minutes of the April 6, 2026, Regular Meeting.**
ITEM 2b. **Acceptance of the Claims List.**
ITEM 2c. **Acknowledge receipt of the Financials for March 2026.**

*Motion by Trustee Alexander, second by Trustee Hatchett to approve Items 2a – 2c.

Roll call vote:

Ayes:” Hatchett, Irving, Ginn, Hebblethwaite, Boyd, Alexander, Talley, Southard, and Grayson.

“Nays:” None.

“Abstain:” None.

Motion passed. 9-0

ITEM 3. Discussion / Approval of Items Removed from Consent Docket:

No Action Taken.

ITEM 4 Discussion and Consideration:

ITEM 4a. Discussion, consideration, and possible action to approve Change Order 2 for project CMA-2501, Sanitary Sewer Main Replacement Colorado Avenue at 4th Street.

*Motion by Council Member Hebblethwaite, second by Council Member Alexander to approve Change Order 2 for project CMA-2501, Sanitary Sewer Main Replacement Colorado Avenue at 4th Street.

Roll call vote:

“Ayes:” Hatchett, Irving, Ginn, Hebblethwaite, Boyd, Alexander, Talley, Southard, and Grayson.

“Nays:” None.

“Abstain:” None

Motion passed. 9-0

ITEM 4b. Discussion, consideration, and possible action to approve final Pay Request No. 3 in the amount of \$15,740.88 – CMA-2501 – Sanitary Sewer Main Replacement Colorado Avenue at 4th Street.

*Motion by Council Member Alexander, second by Council Member Hatchett to approve Final Pay Request No. 3 in the amount of \$15,740.88 - CMA-2501, Sanitary Sewer Main Replacement Colorado Avenue at 4th Street.

Roll call vote:

“Ayes:” Hatchett, Irving, Ginn, Hebblethwaite, Boyd, Alexander, Talley, Southard, and Grayson.

“Nays:” None.

“Abstain:” None

Motion passed. 9-0

ITEM 4c. Discussion, consideration, and possible action to approve the award of a contract to Bills Custom Concrete and Drainage Inc. in the amount of \$111,750.00 for the construction of a storm drain and removal and replacement of existing tin horn, curb and gutter, cul-de-sac, and drainage

flumes at Willow Creek and authorize the Mayor to execute any necessary documents.

*Motion by Council Member Hebblethwaite, second by Council Member Alexander to approve the award of a contract to Bills Custom Concrete and Drainage Inc. in the amount of \$111,750.00 for the construction of a storm drain and removal and replacement of existing tin horn, curb and gutter, cul-de-sac, and drainage flumes at Willow Creek and to authorize the Mayor to execute any necessary documents.

** Amended Motion by Council Member Hebblethwaite, second by Council Member Alexander to approve the award of a contract to Bills Custom Concrete and Drainage Inc. in the amount of \$111,750.00 for the construction of a storm drain and removal and replacement of existing tin horn, curb and gutter, cul-de-sac, and drainage flumes at 419 Willow Creek and to authorize the Mayor to execute any necessary documents.

Roll call vote:

“Ayes:” Hatchett, Irving, Ginn, Hebblethwaite, Boyd, Alexander, Talley, Southard, and Grayson.
“Nays:” None.
“Abstain:” None
Motion passed. 9-0

ITEM 4d. Discussion, consideration, and possible action to enter into an Agreement with Wright Water Corporation for Operation, Maintenance, and Management for Water and Wastewater Treatment Facilities and authorize the Chairman to execute the same.

*Motion by Council Member Alexander, second by Council Member Hatchett to enter into an Agreement with Wright Water Corporation for Operation, Maintenance, and Management for Water and Wastewater Treatment Facilities and authorize the Chairman to execute the same.

Roll call vote:

“Ayes:” Hatchett, Irving, Ginn, Hebblethwaite, Boyd, Alexander, Talley, Southard, and Grayson.
“Nays:” None.
“Abstain:” None
Motion passed. 9-0

ITEM 5 Motion to Adjourn.

*Motion by Trustee Hatchett, second by Trustee Hebblethwaite to adjourn.

Meeting adjourned.

TIME: 7:15 p.m.

Approved this 4th day of May 2026.

Chickasha Municipal Authority Meeting 4-20-2026
TIME 7:06 P.M.

Zachary Grayson, Chairman

Susan M. McDaniel, CMC – City Clerk

(ATTEST)

CHICKASHA

Meeting Type: CMA Agenda 5-4-2026

Meeting Date: 5/4/2026

Department: Finance

Agenda Item No. 2.b.

AGENDA ITEM: Acceptance of the Claims List.

I. BACKGROUND/DESCRIPTION:

II. RECOMMENDED ACTION:

III. FISCAL INFORMATION -

IV. FUND INFORMATION:

Dept. Director:	Fund	Account	Amount
Rich Edwards, Finance Director	(To)		
	FUND	ACCOUNT	AMOUNT
Meeting Date:	(From)		
May 4, 2026			

V. ATTACHMENTS:

CHICKASHA

Meeting Type: CMA Agenda 5-4-2026

Meeting Date: 5/4/2026

Department: Finance

Agenda Item No. 2.c.

AGENDA ITEM: Accept and ratify action to engage HSPG & Associates, LLC to perform the City of Chickasha's audit services for FY25 and FY 26 and authorize Chairman to execute the same.

I. BACKGROUND/DESCRIPTION:

II. RECOMMENDED ACTION:

Accept and ratify action to engage HSPG & Associates, LLC to perform the City of Chickasha's audit services for FY25 and FY 26 and authorize Chairman to execute the same.

III. FISCAL INFORMATION -

IV. FUND INFORMATION:

Dept. Director:	Fund	Account	Amount
	(To)		
	FUND	ACCOUNT	AMOUNT
Meeting Date: May 4, 2026	(From)		

V. ATTACHMENTS:

1. Chickasha engagement letter-2025 and 2026



April 24, 2026

To the City Council and management of
The City of Chickasha, Oklahoma

We are pleased to confirm our understanding of the services we are to provide for the City of Chickasha, Oklahoma (the “City”) for the years ended June 30, 2025 and 2026.

Audit Scope and Objectives

We will audit the modified cash basis financial statements of the governmental activities, the business-type activities, each major fund, and the aggregate remaining fund information, including the disclosures, which collectively comprise the basic financial statements, of the City as of and for the years ended June 30, 2025 and 2026.

We have also been engaged to report on supplementary information that accompanies the City’s financial statements. We will subject the following supplementary information to the auditing procedures applied in our audits of the financial statements and certain additional procedures, including comparing and reconciling such information directly to the underlying accounting and other records used to prepare the financial statements or to the financial statements themselves, and other additional procedures in accordance with generally accepted auditing standards (“GAAS”), and we will provide an opinion on it in relation to the financial statements as a whole in a report combined with our auditor’s report on the financial statements.

- 1) Schedule of expenditures of federal and state awards (modified cash basis), if necessary
- 2) Combining schedules (modified cash basis)

In connection with our audit of the basic financial statements, we will read the following other information and consider whether a material inconsistency exists between the other information and the basic financial statements, or the other information otherwise appears to be materially misstated. If, based on the work performed, we conclude that an uncorrected material misstatement of the other information exists, we are required to describe it in our report.

- 1) Management’s discussion and analysis
- 2) Budgetary comparison information (modified cash basis)

The objectives of our audits are to obtain reasonable assurance about whether the financial statements as a whole are free from material misstatement, whether due to fraud or error, and issue an auditor’s report that includes our opinions about whether your financial statements are fairly presented, in all material respects, in conformity with the modified cash basis of accounting, which is an other comprehensive basis of accounting other than generally accepted accounting principles (GAAP), and report on the fairness of the supplementary information referred to in the second paragraph when considered in relation to the financial statements as a whole. Reasonable assurance is a high level of assurance but is not absolute assurance and therefore is not a guarantee that an audit conducted in accordance with GAAS and *Government Auditing Standards* will always detect a material misstatement when it exists. Misstatements, including omissions, can arise from fraud or error and are considered material if there is a substantial likelihood that, individually or in the aggregate, they would influence the judgment of a reasonable user made based on the financial statements.

HSPG & ASSOCIATES, PC

The objectives also include reporting on:

- Internal control over financial reporting and compliance with provisions of laws, regulations, contracts, and award agreements, noncompliance with which could have a material effect on the financial statements in accordance with *Government Auditing Standards*.
- If necessary, internal control over compliance related to major programs and an opinion (or disclaimer of opinion) on compliance with federal statutes, regulations, and the terms and conditions of federal awards that could have a direct and material effect on each major program in accordance with the Single Audit Act Amendments of 1996 and Title 2 U.S. *Code of Federal Regulations* (CFR) Part 200, *Uniform Administrative Requirements, Cost Principles, and Audit Requirements for Federal Awards* (Uniform Guidance).

Auditor’s Responsibilities for the Audit of the Financial Statements and Single Audit

We will conduct our audits in accordance with GAAS; the standards for financial audits contained in *Government Auditing Standards*, issued by the Comptroller General of the United States; and if necessary, the Single Audit Act Amendments of 1996; and the provisions of the Uniform Guidance, and will include tests of accounting records, a determination of major program(s) in accordance with Uniform Guidance, and other procedures we consider necessary to enable us to express such opinions. As part of an audit in accordance with GAAS and *Government Auditing Standards*, we exercise professional judgment and maintain professional skepticism throughout the audit.

We will evaluate the appropriateness of accounting policies used and the reasonableness of significant accounting estimates made by management. We will also evaluate the overall presentation of the financial statements, including the disclosures, and determine whether the financial statements represent the underlying transactions and events in a manner that achieves fair presentation. We will plan and perform the audits to obtain reasonable assurance about whether the financial statements are free of material misstatement, whether from (1) errors, (2) fraudulent financial reporting, (3) misappropriation of assets, or (4) violations of laws or governmental regulations that are attributable to the government or to acts by management or employees acting on behalf of the government. Because the determination of waste and abuse is subjective, *Government Auditing Standards* do not expect auditors to perform specific procedures to detect waste or abuse in financial audits nor do they expect auditors to provide reasonable assurance of detecting waste or abuse.

Because of the inherent limitations of an audit, combined with the inherent limitations of internal control, and because we will not perform a detailed examination of all transactions, there is an unavoidable risk that some material misstatements or noncompliance may not be detected by us, even though the audit is properly planned and performed in accordance with GAAS and *Government Auditing Standards*. In addition, an audit is not designed to detect immaterial misstatements or violations of laws or governmental regulations that do not have a direct and material effect on the financial statements or on major programs. However, we will inform the appropriate level of management of any material errors, any fraudulent financial reporting, or misappropriation of assets that come to our attention. We will also inform the appropriate level of management of any violations of laws or governmental regulations that come to our attention, unless clearly inconsequential. If necessary, we will include such matters in the reports required for a Single Audit. Our responsibility as auditors is limited to the period covered by our audit and does not extend to any later periods for which we are not engaged as auditors.

We will also conclude, based on the audit evidence obtained, whether there are conditions or events, considered in the aggregate, that raise substantial doubt about the government’s ability to continue as a going concern for a reasonable period of time.

Our procedures will include tests of documentary evidence supporting the transactions recorded in the accounts and direct confirmation of receivables and certain assets and liabilities by correspondence with selected individuals, funding sources, creditors, and financial institutions. We may also request written representations from your attorneys as part of the engagement.

We have identified the following significant risk(s) of material misstatement as part of our audit planning:

- Revenue recognition
- Management override of controls

Our audit of financial statements does not relieve you of your responsibilities.

Audit Procedures—Internal Control

We will obtain an understanding of the government and its environment, including the system of internal control, sufficient to identify and assess the risks of material misstatement of the financial statements, whether due to error or fraud, and to design and perform audit procedures responsive to those risks and obtain evidence that is sufficient and appropriate to provide a basis for our opinions. The risk of not detecting a material misstatement resulting from fraud is higher than for one resulting from error, as fraud may involve collusion, forgery, intentional omissions, misrepresentation, or the override of internal control. Tests of controls may be performed to test the effectiveness of certain controls that we consider relevant to preventing and detecting errors and fraud that are material to the financial statements and to preventing and detecting misstatements resulting from illegal acts and other noncompliance matters that have a direct and material effect on the financial statements. Our tests, if performed, will be less in scope than would be necessary to render an opinion on internal control and, accordingly, no opinion will be expressed in our report on internal control issued pursuant to *Government Auditing Standards*.

As required by the Uniform Guidance, we will, if necessary, perform tests of controls over compliance to evaluate the effectiveness of the design and operation of controls that we consider relevant to preventing or detecting material noncompliance with compliance requirements applicable to each major federal award program. However, our tests will be less in scope than would be necessary to render an opinion on those controls and, accordingly, no opinion will be expressed in our report on internal control issued pursuant to the Uniform Guidance.

An audit is not designed to provide assurance on internal control or to identify significant deficiencies or material weaknesses. Accordingly, we will express no such opinion. However, during the audits, we will communicate to management and those charged with governance internal control related matters that are required to be communicated under AICPA professional standards, *Government Auditing Standards*, and, if necessary, the Uniform Guidance.

Audit Procedures—Compliance

As part of obtaining reasonable assurance about whether the financial statements are free of material misstatement, we will perform tests of the City's compliance with provisions of applicable laws, regulations, contracts, and agreements, including grant agreements. However, the objective of those procedures will not be to provide an opinion on overall compliance, and we will not express such an opinion in our report on compliance issued pursuant to *Government Auditing Standards*.

If a single audit is necessary, the Uniform Guidance requires that we also plan and perform the audit to obtain reasonable assurance about whether the auditee has complied with federal statutes, regulations, and the terms and conditions of federal awards applicable to major programs. Our procedures will consist of tests of transactions and other applicable procedures described in the *OMB Compliance Supplement* for the types of compliance requirements that could have a direct and material effect on each of the City's major programs. For federal programs that are included in the Compliance Supplement, our compliance and internal control procedures will relate to the compliance requirements that the Compliance

Supplement identifies as being subject to audit. The purpose of these procedures will be to express an opinion on the City's compliance with requirements applicable to each of its major programs in our report on compliance issued pursuant to the Uniform Guidance.

Responsibilities of Management for the Financial Statements and Single Audit

Our audits will be conducted on the basis that you acknowledge and understand your responsibility for (1) designing, implementing, establishing, and maintaining effective internal controls relevant to the preparation and fair presentation of financial statements that are free from material misstatement, whether due to fraud or error, including internal controls over federal awards, and for evaluating and monitoring ongoing activities to help ensure that appropriate goals and objectives are met; (2) following laws and regulations; (3) ensuring that there is reasonable assurance that government programs are administered in compliance with compliance requirements; and (4) ensuring that management and financial information is reliable and properly reported. Management is also responsible for implementing systems designed to achieve compliance with applicable laws, regulations, contracts, and grant agreements. You are also responsible for the selection and application of accounting principles; for the preparation and fair presentation of the financial statements, schedule of expenditures of federal awards, and all accompanying information in conformity with the modified cash basis of accounting and for compliance with applicable laws and regulations (including federal statutes), rules, and the provisions of contracts and grant agreements (including award agreements). Your responsibilities also include identifying significant contractor relationships in which the contractor has responsibility for program compliance and for the accuracy and completeness of that information.

You are also responsible for making drafts of financial statements, schedule of expenditures of federal awards, all financial records, and related information available to us, for the accuracy and completeness of that information (including information from outside of the general and subsidiary ledgers); and for the evaluation of whether there are any conditions or events, considered in the aggregate, that raise substantial doubt about the government's ability to continue as a going concern for the 12 months after the financial statements date or shortly thereafter (for example, within an additional three months if currently known). You are also responsible for providing us with (1) access to all information of which you are aware that is relevant to the preparation and fair presentation of the financial statements, such as records, documentation, identification of all related parties and all related-party relationships and transactions, and other matters; (2) access to personnel, accounts, books, records, supporting documentation, and other information as needed to perform an audit under the Uniform Guidance if required; (3) additional information that we may request for the purpose of the audit; and (4) unrestricted access to persons within the government from whom we determine it necessary to obtain audit evidence. At the conclusion of our audits, we will require certain written representations from you about the financial statements; schedule of expenditures of federal awards; federal award programs; compliance with laws, regulations, contracts, and grant agreements; and related matters.

Your responsibilities include adjusting the financial statements to correct material misstatements and confirming to us in the management representation letter that the effects of any uncorrected misstatements aggregated by us during the current engagement and pertaining to the latest period presented are immaterial, both individually and in the aggregate, to the financial statements of each opinion unit taken as a whole.

You are responsible for the design and implementation of programs and controls to prevent and detect fraud, and for informing us about all known or suspected fraud affecting the government involving (1) management, (2) employees who have significant roles in internal control, and (3) others where the fraud could have a material effect on the financial statements. Your responsibilities include informing us of your knowledge of any allegations of fraud or suspected fraud affecting the government received in communications from employees, former employees, grantors, regulators, or others. In addition, you are

responsible for identifying and ensuring that the government complies with applicable laws, regulations, contracts, agreements, and grants. You are also responsible for taking timely and appropriate steps to remedy fraud and noncompliance with provisions of laws, regulations, contracts, and grant agreements that we report. Additionally, as required by the Uniform Guidance, it is management's responsibility to evaluate and monitor noncompliance with federal statutes, regulations, and the terms and conditions of federal awards; take prompt action when instances of noncompliance are identified including noncompliance identified in audit findings; promptly follow up and take corrective action on reported audit findings; and prepare a summary schedule of prior audit findings and a separate corrective action plan.

You are responsible for identifying all federal awards received and understanding and complying with the compliance requirements and for the preparation of the schedule of expenditures of federal awards (including notes and noncash assistance received, and COVID-19-related concepts, such as lost revenues, if applicable) in conformity with the Uniform Guidance if necessary. You agree to include our report on the schedule of expenditures of federal awards in any document that contains, and indicates that we have reported on, the schedule of expenditures of federal awards.

You also agree to include the audited financial statements with any presentation of the schedule of expenditures of federal awards that includes our report thereon or make the audited financial statements readily available to intended users of the schedule of expenditures of federal awards no later than the date the schedule of expenditures of federal awards is issued with our report thereon. Your responsibilities include acknowledging to us in the written representation letter that (1) you are responsible for presentation of the schedule of expenditures of federal awards in accordance with the Uniform Guidance; (2) you believe the schedule of expenditures of federal awards, including its form and content, is stated fairly in accordance with the Uniform Guidance; (3) the methods of measurement or presentation have not changed from those used in the prior period (or, if they have changed, the reasons for such changes); and (4) you have disclosed to us any significant assumptions or interpretations underlying the measurement or presentation of the schedule of expenditures of federal awards.

You are also responsible for the preparation of the other supplementary information, which we have been engaged to report on, in conformity with the modified cash basis of accounting. You agree to include our report on the supplementary information in any document that contains, and indicates that we have reported on, the supplementary information. You also agree to include the audited financial statements with any presentation of the supplementary information that includes our report thereon or make the audited financial statements readily available to users of the supplementary information no later than the date the supplementary information is issued with our report thereon. Your responsibilities include acknowledging to us in the written representation letter that (1) you are responsible for presentation of the supplementary information in accordance with the modified cash basis of accounting; (2) you believe the supplementary information, including its form and content, is fairly presented in accordance with the modified cash basis of accounting; (3) the methods of measurement or presentation have not changed from those used in the prior period (or, if they have changed, the reasons for such changes); and (4) you have disclosed to us any significant assumptions or interpretations underlying the measurement or presentation of the supplementary information.

Management is responsible for establishing and maintaining a process for tracking the status of audit findings and recommendations. Management is also responsible for identifying and providing report copies of previous financial audits, attestation engagements, performance audits, or other studies related to the objectives discussed in the Audit Scope and Objectives section of this letter. This responsibility includes relaying to us corrective actions taken to address significant findings and recommendations resulting from those audits, attestation engagements, performance audits, or studies. You are also responsible for providing management's views on our current findings, conclusions, and recommendations, as well as your planned corrective actions for the report, and for the timing and format for providing that information.

Engagement Administration, Fees, and Other

We understand that your employees will prepare all cash or other confirmations we request and will locate any documents selected by us for testing.

If required, at the conclusion of the engagement, we will complete the appropriate sections of the Data Collection Form that summarizes our audit findings. It is management's responsibility to electronically submit the reporting package (including financial statements, schedule of expenditures of federal awards, summary schedule of prior audit findings, auditor's reports, and corrective action plan) along with the Data Collection Form to the federal audit clearinghouse. We will coordinate with you the electronic submission and certification.

The Data Collection Form and the reporting package must be submitted within the earlier of 30 calendar days after receipt of the auditor's reports or nine months after the end of the audit period.

We will provide copies of our reports to the City; however, management is responsible for distribution of the reports and the financial statements. Unless restricted by law or regulation, or containing privileged and confidential information, copies of our reports are to be made available for public inspection. With regard to publishing the financial statements on your website, you understand that websites are a means of distributing information and, therefore, we are not required to read the information contained in those sites or to consider the consistency of other information on the website with the original document.

The audit documentation for this engagement is the property of HSPG & Associates and constitutes confidential information. However, subject to applicable laws and regulations, audit documentation and appropriate individuals will be made available upon request and in a timely manner to a federal agency providing direct or indirect funding, or the U.S. Government Accountability Office for purposes of a quality review of the audit, to resolve audit findings, or to carry out oversight responsibilities. We will notify you of any such request. If requested, access to such audit documentation will be provided under the supervision of HSPG & Associates personnel. Furthermore, upon request, we may provide copies of selected audit documentation to the aforementioned parties. These parties may intend, or decide, to distribute the copies or information contained therein to others, including other governmental agencies.

The audit documentation for this engagement will be retained for a minimum of five years after the report release date or for any additional period requested by an outside regulator. If we are aware that a federal awarding agency, pass-through entity, or auditee is contesting an audit finding, we will contact the party(ies) contesting the audit finding for guidance prior to destroying the audit documentation.

Andy Cromer is the engagement partner and is responsible for supervising the engagement and signing the reports or authorizing another individual to sign them. We expect to begin our fiscal 2025 audit by July 13, 2026, and issue our report by September 30, 2026. This deadline is contingent upon the City's accounts being properly reconciled and the timely assistance and turnaround of requests by the City or its consultants. We will not be responsible for any failure to meet this deadline to the extent it is caused by the City or its consultants.

Our base fee for the financial statement audits will be \$54,250 and \$56,000 for fiscal 2025 and 2026, respectively. However, to assist the City in meeting its deadline for filing its audit, we have reassigned team members to your engagement that were not originally contemplated. Therefore, we will also bill the City an additional \$25 per hour for engagement team members designated as manager or above, except that such additional fees will not exceed \$12,000. Additionally, if a single audit is required, our fee will be an additional \$9,000 for each major program. These fees include our miscellaneous charges, such as travel and meals. Our invoices for these fees will be rendered each month as work progresses and are payable on presentation. The above fees are based on anticipated cooperation from your personnel and the assumption that unexpected circumstances will not be encountered during the engagement. If significant additional time is necessary, we will keep you informed of any problems we encounter and our fees will be adjusted accordingly.

Reporting

We will issue written reports upon completion of our audits. Our reports will be addressed to the City Council and management of the City. Circumstances may arise in which our report may differ from its expected form and content based on the results of our audits. Depending on the nature of these circumstances, it may be necessary for us to modify our opinions, add a separate section, or add an emphasis-of-matter or other-matter paragraph to our auditor’s report, or if necessary, withdraw from this engagement. If our opinions are other than unmodified, we will discuss the reasons with you in advance. If, for any reason, we are unable to complete the audit or are unable to form or have not formed opinions, we may decline to express opinions or issue reports, or we may withdraw from this engagement.

The *Government Auditing Standards* report on internal control over financial reporting and on compliance and other matters will state that (1) the purpose of the report is solely to describe the scope of testing of internal control and compliance and the results of that testing, and not to provide an opinion on the effectiveness of the entity’s internal control or on compliance, and (2) the report is an integral part of an audit performed in accordance with *Government Auditing Standards* in considering the entity’s internal control and compliance. If required, the Uniform Guidance report on internal control over compliance will state that the purpose of the report on internal control over compliance is solely to describe the scope of testing of internal control over compliance and the results of that testing based on the requirements of the Uniform Guidance. Both reports will state that the report is not suitable for any other purpose.

We appreciate the opportunity to be of service to the City and believe this letter accurately summarizes the significant terms of our engagement. If you have any questions, please let us know. If you agree with the terms of our engagement as described in this letter, please sign a copy of this letter and return it to us.

Sincerely,

HSPG & Associates, P.C.

HSPG & Associates, P.C.

RESPONSE:

This letter correctly sets forth the understanding of the City of Chickasha, Oklahoma .

Management signature: _____

Title: _____

Governance signature: _____

Title: _____

CHICKASHA

Meeting Type: CMA Agenda 5-4-2026

Meeting Date: 5/4/2026

Department: Administration

Agenda Item No. 4.a.

AGENDA ITEM: Discussion, consideration, and possible action to authorize the Chairman to execute a Task Order with WSB Engineering under the existing Master Service Agreement for Congo Creek Basin #1 – Drainage Design in the amount of \$117,545.00.

I. BACKGROUND/DESCRIPTION:

In September 2024, the City of Chickasha executed a Master Service Agreement (MSA) with Meshak Engineering, which was acquired by WSB in November 2024. The MSA provides support for implementing priority projects from the City's Master Drainage Plan and strengthens eligibility for state, federal, and private funding opportunities.

The Congo Creek Basin #1 project area - located along Pondridge Road and Scissortail Lane - was identified during the scoping phase as a priority flood-risk location. Recurring street flooding continues to affect public infrastructure and adjacent private property. WSB is prepared to begin design and implementation of the recommended drainage improvements.

The proposed scope of services includes hydrologic and hydraulic analysis to evaluate conceptual drainage alternatives (Options 1, 2, and 3), topographic survey and site investigation, final design plans for the selected improvement, and bidding and construction phase services.

FISCAL IMPACT:

Total Task Order Amount: \$117,545.00

- Project Management: \$9,483.00
- Part 1: Hydraulic Analysis: \$9,528.00
- Part 2: Site Investigation: \$31,780.00
- Part 3: Design: \$53,302.00
- Part 4: Bidding & Construction Mgmt: \$12,452.00
- Expenses: \$1,000.00

II. RECOMMENDED ACTION:

Authorize the Chairman to execute a Task Order with WSB Engineering under the existing Master Service Agreement for Congo Creek Basin #1 – Drainage Design in the amount of \$117,545.00.

III. FISCAL INFORMATION -

IV. FUND INFORMATION:

Dept. Director: Edward Perez, EM Director	Fund	Account	Amount
	(To)		
	FUND	ACCOUNT	AMOUNT
Meeting Date: May 4, 2026	(From)		
	31 539-6450-017		

V. ATTACHMENTS:

1. Congo Creek Basin #1 Fee Proposal
2. Congo_Upstream_Basin1_Concept_Proposal_Map

March 13, 2026

Mr. Jim Crosby, City Manager
Chickasha City Hall
117 N. 4th Street
Chickasha, OK 73018

City of Chickasha - Congo Creek Basin #1 - Drainage Design

Dear Mr. Crosby,

WSB appreciates the opportunity to submit this proposal to support the City of Chickasha with stormwater drainage improvements near Pondridge Road and Scissortail Lane. Our proposed scope of services includes hydrologic and hydraulic analysis to evaluate conceptual alternatives for addressing recurring street flooding conditions, development of final design plans for the selected improvement, and construction phase services. The attached Preliminary Proposal outlines our approach to assessing the existing drainage system, comparing viable solutions, and delivering a project ready for construction.

Project Management

- Contract Administration
- Correspondence
- Meetings
- Plan review

Part 1: Hydraulic Analysis

- Drainage Option Determination
 - Options 1, 2, and 3
 - Final analysis to identify the most cost-effective drainage solution.

Part 2: Site Investigation

- Topographic Survey
 - Control:
 - Control points and benchmarks established on the Oklahoma State Plane South coordinate system.
 - Topographic/Planimetric Survey:
 - Natural ground features including flowlines, ditches, slopes, and tree lines
 - Structures, paving, fences, and other observed improvements.
 - Property Survey:
 - Locations of property lines, easements, and rights-of-way as filed of record with the Grady County Clerk and available on-line will be shown in the DWG file.
 - Utilities:
 - Atlas information and field observation, Quality Level C.
 - Deliverables:
 - Civil 3D DWG and Certified Survey Data Sheet in PDF.

Part 3: Design

- Hydrology & Hydraulics
 - Detention Pond Design
 - Inlet & Pipe Design
- Civil Plan Design
 - Preliminary Plans
 - 95% Plan Documents
 - Cost Estimate
 - Construction Plans
 - Final Plan Documents
 - Construction Cost Estimate

Part 4: Bidding & Construction

- Bid Documents & Bidding
 - Prepare bid documents
 - Pre-Bid Meeting
 - RFI Review & Response
 - Bid Opening & Recommendations
- Construction Project Management
 - Pay Application Review
 - Pre-Construction Meeting
 - Submittal Review
 - Construction Progress Meetings
 - Final Inspection/Punch List/Acceptance Recommendation

Exclusions

- Sub-surface utilities (SUE) survey
- Geotechnical Investigation

Additional services will be considered a change in scope. Changes in scope and hours will be negotiated through an addendum to the contract.

All work will be billed monthly on a percent-complete basis. All fees for permitting will be paid by the owner of the property.

The fee to perform the outlined scope of services is:

Project Management_____	\$ 9,483.00
Part 1: Hydraulic Analysis_____	\$ 9,528.00
Part 2: Site Investigation_____	\$ 31,780.00
Part 3: Design_____	\$ 53,302.00
Part 4: Bidding & Construction Management_____	\$ 12,452.00
Expenses_____	\$ 1,000.00
Total:	\$ 117,545.00

This fee proposal will remain valid for 90 days. If you find this proposal acceptable, WSB will prepare an agreement for execution. If you have any questions or need additional information, please contact me at 405.229.3260. I look forward to working with you on this project.

Sincerely,

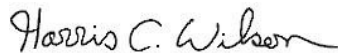

Harris Wilson , PE
Senior Project
Manager



[405.229.3260](tel:405.229.3260) (o)
-
615 N Hudson Avenue, Suite 300
Oklahoma City, OK 73102
wsbeng.com

Congo Creek Basin #1 Concept Map

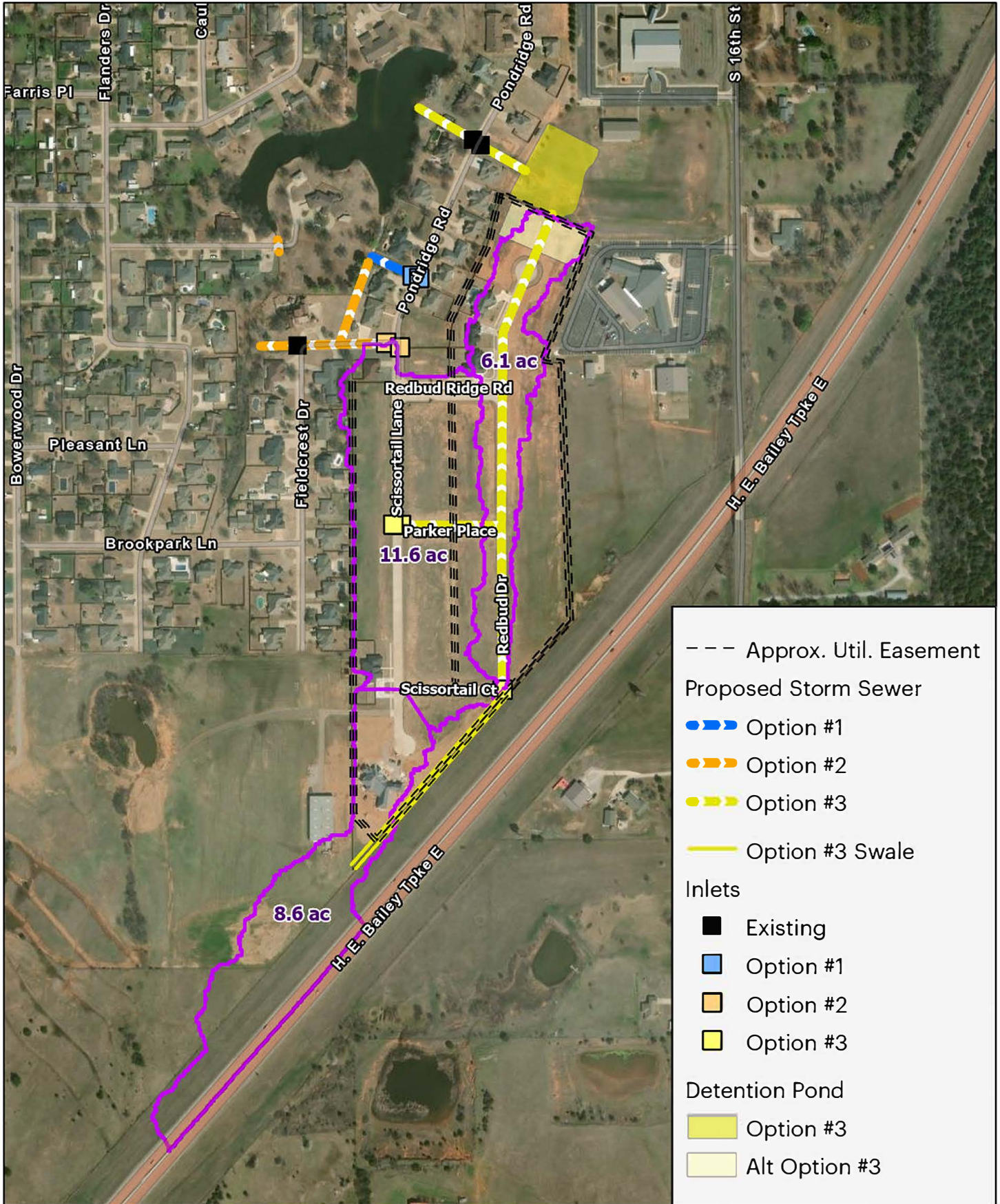
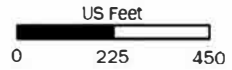

- Approx. Util. Easement
- Proposed Storm Sewer
- Option #1
- Option #2
- Option #3
- Option #3 Swale
- Inlets
- Existing
- Option #1
- Option #2
- Option #3
- Detention Pond
- Option #3
- Alt Option #3

Potential Stormwater Improvements



CHICKASHA

Meeting Type: CMA Agenda 5-4-2026

Meeting Date: 5/4/2026

Department: Public Works

Agenda Item No. 4.b.

AGENDA ITEM: Discussion, consideration and possible action to authorize the purchase of a 2026 Ram 2500 Crew Tradesman 4x4 Truck using State Contract SW0035M in the amount of \$47,123.00.

I. BACKGROUND/DESCRIPTION:

II. RECOMMENDED ACTION:

Authorize the purchase of a 2026 Ram 2500 Crew Tradesman 4x4 Truck using State Contract SW0035M in the amount of \$47,123.00.

III. FISCAL INFORMATION -

IV. FUND INFORMATION:

Dept. Director: Omar Fierro, Public Works Director	Fund	Account	Amount
	(To)		
Meeting Date: May 4, 2026	FUND	ACCOUNT	AMOUNT
	(From)		

V. ATTACHMENTS:

1. 20260415114946847

AGENDA MEMO

To: City Council
From: Omar Fierro, Director of Public Works
Date: April 20th 2026
Subject: Replacement of Outdated Fleet Vehicle

BACKGROUND

The Public Works Department currently operates a fleet vehicle that has exceeded its useful service life. The vehicle has become increasingly unreliable, requiring frequent repairs and maintenance. These ongoing issues have resulted in increased operational costs, reduced efficiency, and potential disruptions to essential services.

DISCUSSION

As part of the City’s ongoing fleet management, staff recommends replacing this outdated vehicle to ensure continued reliability and efficiency in daily operations.

Replacing aging fleet vehicles is essential to maintaining consistent service levels and supporting the City’s infrastructure and maintenance responsibilities.

FISCAL IMPACT

Funding for this vehicle replacement has been budgeted and will cover all associated costs, including purchase, delivery, and any necessary equipment or upfitting.

RECOMMENDATION

Staff respectfully request City Council approval to proceed with the replacement of the outdated fleet vehicle.

Sincerely,
Director of Public Works: *Omar Fierro* _____.

COMMERCIAL & GOVERNMENT FLEET
 SALES
 11001 W RENO
 YUKON OK 73099



QUOTE

DATE	2/19/2026
QUOTE NUMBER	BW0Q1158
EXPIRATION DATE	3/12/2026
SHIP VIA	TO BE ORDERED
TERMS	OKLAHOMA STATE CONTRACT

SOLD TO: City of Chickasha Tim Brooks 117 N. 4th St Chickasha, OK 73018 405-544-6576	SHIP TO: City of Chickasha Tim Brooks 117 N. 4th St Chickasha, OK 73018 405-544-6576	Any Questions? Call (405) 229-5690 Britt Woods CAM
--	--	---

Qty	OPTION	Description	Unit Price	Ext. Price
1	DJ7L92	2026 RAM 2500 CREW TRADESMAN 4X4 LWB	\$42,537.00	\$42,537.00
1	4WD	FOUR WHEEL DRIVE	\$1,985.00	\$1,985.00
1	LWB	LONG WHEEL BASE 8' BED	\$2,250.00	\$2,250.00
1	2UA	TRADESMAN TRIM LEVEL	\$0.00	\$0.00
1	ESL	6.4L V8 HEMI GASOLINE	\$0.00	\$0.00
1	DFX	8SPD AUTO TRANS	\$0.00	\$0.00
1	DME	3.73 AXLE RATIO	\$0.00	\$0.00
1	WBF	18" X 8" BLACK PAINTED STEEL WHEELS	\$0.00	\$0.00
1	TCP	18" ALL TERRAIN TIRES	\$0.00	\$0.00
1	AGS	COMMERCIAL LKFEATURES PACKAGE W/ FRONT AND REAR PARK ASSIST	\$0.00	\$0.00
1	A7B	TRADESMAN LEVEL 1 PACKAGE -inc: Convenience Group, Emergency Vehicle Alert System (EVAS), 12" Touchscreen Display, Auto Power-Folding Mirrors, Anti-Spin Differential Rear Axle, Mirror Running Lights, Exterior 115V AC Outlet, Alexa Built-In, Power-Adjustable Convex Aux Mirrors, Forward & Reverse Utility Lights, Disassociated Touchscreen Display, 115V Auxiliary Front Power Outlet, Rear View Auto Dim Mirror, Rear Power Sliding Window, Tinted Acoustic Windshield Glass, GPS Navigation, Exterior Mirrors w/Heating Element, MOPAR Black Tubular Side Steps, SiriusXM w/360L, Connected Travel & Traffic Services, Carpet Floor Covering, Off-Road Info Pages, Trailer Tow Pages, 400W Inverter, HD Radio, Power Heated Folding Telescope Mirrors, Radio: Uconnect 5 Nav w/12.0" Display, Exterior Mirrors w/Supplemental Signals, Exterior Mirrors Courtesy Lamps, Air Conditioning ATC w/Dual Zone Control, Power Adjust Mirrors, Power Telescoping Mirrors, Front & Rear Floor Mats, ParkSense Front/Rear Park Assist System	\$0.00	\$0.00
1	XEF	SKID PLATES	\$90.00	\$90.00
1	MRU	BLACK MOPAR TUBULAR STEPS	\$0.00	\$0.00
1	MDA	FRONT TAG BRACKET	\$0.00	\$0.00
1	XCH	2 EXTRA KEY FOBS 4 TOTAL KEY FOBS PER TRUCK	\$261.00	\$261.00
1	CBU	VINYL SEAT	\$0.00	\$0.00
1	PW7		\$0.00	\$0.00

Accepted By: _____

Terms:

THIS QUOTE DOES NOT GUARANTEE THE FACTORY WILL BUILD THE VEHICLE.

1) TAG & TAXES ARE NOT INCLUDED UNLESS ITEMIZED ON QUOTE

SUB-TOTAL	\$47,123.00
	\$0.00
TOTAL DUE	\$47,123.00

1 of 2

Qty	OPTION	Description	Unit Price	Ext. Price
1	TXX8	EXTERIOR : BRIGHT WHITE INTERIOR : VINLY 40/20/40 SPLIT BENCH SEAT BLACK / DIESEL GRAY	\$0.00	\$0.00
		SubTotal		\$47,123.00
		<i>OPTIONS LISTED BELOW NOT ADDED TO TOTAL PLEASE ADD AS DESIRED</i>		
1	ETN	6.7L I6 CUMMINS TURBO DIESEL (Optional)	\$12,345.25	\$12,345.25
1	NHK	ENGINE BLOCK HEATER (Optional)	\$185.25	\$185.25

Accepted By: _____

Terms:

THIS QUOTE DOES NOT GUARANTEE THE FACTORY WILL BUILD THE VEHICLE.

1) TAG & TAXES ARE NOT INCLUDED UNLESS ITEMIZED ON QUOTE

SUB-TOTAL	\$47,123.00
	\$0.00
TOTAL DUE	\$47,123.00
	2 of 2

CHICKASHA

Meeting Type: CMA Agenda 5-4-2026

Meeting Date: 5/4/2026

Department: Administration

Agenda Item No. 4.c.

AGENDA ITEM: Discussion, consideration, and possible action to authorize the Trust Manager and Chairman to execute all necessary documents to support submission of an application under the Oklahoma Disaster Mitigation and Recovery Matching Fund Program (ODMRMF) through the Association of South Central Oklahoma Governments (ASCOG), requesting \$1,687,630 to satisfy the required local match for the BRIC grant-funded design phase of the Line Creek Flood Mitigation Project.

I. BACKGROUND/DESCRIPTION:

The City of Chickasha has experienced recurring and significant flood damage along Line Creek, a one-mile reach running through the downtown business district and surrounding residential neighborhoods south of the Stillwater Central Railroad. WSB Engineering has completed a full engineering analysis and flood modeling study identifying conveyance limitations as the primary driver of this repetitive flooding.

Key findings from the engineering analysis:

- 1,257 structures affected under existing conditions
- 3,268 residents at risk
- \$6.81 million in estimated average annual flood damages
- \$75.37 million in avoided damages over 50 years with full project completion
- Preliminary Benefit-Cost Ratio of 1.20, meeting FEMA's cost-effectiveness threshold

WSB Engineering has recommended submitting a 100% Project Design application under the current FY2024-2025 FEMA Building Resilient Infrastructure and Communities (BRIC) Notice of Funding Opportunity. Completing full project design is the required prerequisite before construction funding can be pursued in a future grant cycle. FEMA's evaluation criteria also award maximum competitive readiness points to communities that have completed designs in place when applying for construction funding.

The Oklahoma Disaster Mitigation and Recovery Matching Fund Program (ODMRMF), administered by the Oklahoma Department of Commerce Community Development Division, provides state funds to help local governments satisfy the local match required by federal grants. Because ODMRMF eligibility is limited to Substate Planning Districts and Councils of Government, the Association of South Central Oklahoma Governments (ASCOG) has agreed to serve as the sponsoring applicant and submit the application through OKGrants on the City's

behalf.

FISCAL IMPACT:

Total ODMRMF Request: \$1,687,630.00

Total Eligible Design Cost: \$6,750,522.00

Federal Share – BRIC Grant (75%): \$5,062,892.00

Required Local Share (25%): \$1,687,630.00

ODMRMF Request (through ASCOG): \$1,687,630.00

If awarded in full, the ODMRMF funds would cover the City's entire required local match for the design phase. No general fund expenditure would be required for the design phase if the award is granted in full. Should the award be less than the full amount, Council would need to consider alternative funding sources for any remaining balance.

Oklahoma ODMRMF application deadline: June 12, 2026

FEMA BRIC federal deadline: July 23, 2026

II. RECOMMENDED ACTION:

Motion to authorize the Trust Manager and Chairman to execute all necessary documents to support submission of an application under the Oklahoma Disaster Mitigation and Recovery Matching Fund Program (ODMRMF) through the Association of South Central Oklahoma Governments (ASCOG), requesting \$1,687,630 to satisfy the required local match for the BRIC grant-funded design phase of the Line Creek Flood Mitigation Project.

III. FISCAL INFORMATION -

IV. FUND INFORMATION:

Dept. Director: Edward Perez, EM Director	Fund	Account	Amount
	(To)		
Meeting Date: May 4, 2026	FUND	ACCOUNT	AMOUNT
	(From)		

V. ATTACHMENTS:

1. Letter of Intent - lineCreek - City Manager
2. Line_Creek_Briefing_FINAL 04262026
3. Oklahoma-Disaster-Mitigation-and-Recovery-Matching-Fund-Program-ODMRMF-Application-Guidance



Office of the City Manager

April 29, 2026

Oklahoma Department of Commerce

Community Development Division

Re: Letter of Intent – Request for \$1,687,630 Matching Funds

Line Creek Flood Mitigation Project – City of Chickasha, Oklahoma

To Whom It May Concern:

The City of Chickasha respectfully submits this Letter of Intent requesting that the Association of South Central Oklahoma Governments (ASCOG) serve as the sponsoring applicant for a \$1,687,630 award under the Oklahoma Disaster Mitigation and Recovery Matching Fund Program (ODMRMF), administered by the Oklahoma Department of Commerce, Community Development Division. Because the ODMRMF requires that applications be submitted through OKGrants by an eligible Substate Planning District or Council of Government, the City of Chickasha requests ASCOG's sponsorship to satisfy this eligibility requirement and to advance the Line Creek Flood Mitigation Project. If awarded, these funds would fully satisfy the City's required local match for the BRIC grant-funded design phase of the project.

This project is a critical flood mitigation initiative designed to reduce recurring flood risk to Chickasha's downtown business district, residential neighborhoods, transportation corridors, and public infrastructure. Engineering analysis completed by WSB Engineering identified conveyance limitations along Line Creek as a major contributor to repetitive flooding and determined that bridge replacements and channel improvements are necessary to significantly reduce future damages.

Current flood modeling shows:

- 1,257 structures affected under existing conditions;
- 3,268 residents at risk;
- \$6.81 million in estimated annual flood damages;
- \$75.37 million in avoided damages over 50 years with full project completion; and
- A Preliminary Benefit-Cost Ratio of 1.20, demonstrating cost effectiveness.

The requested funds would be used specifically to satisfy the non-federal cost share associated with the BRIC grant-funded design phase of the project. The total eligible design cost is estimated at \$6,750,522, with a federal share of \$5,062,892 and a required local share of \$1,687,630. This request for \$1,687,630 would fully cover the City's required local match and allow the project to move forward.

City of Chickasha

117 North 4th Street, Chickasha, OK 73018 • 405-222-6045 Jim.Crosby@chickasha.org

The City of Chickasha is an equal opportunity employer and provider. For TDD/TTY assistance, please dial 711.



Office of the City Manager

Cost Category	Amount
Total Eligible Design Cost	\$6,750,522
Federal Share (BRIC Grant)	\$5,062,892
Required Local Share	\$1,687,630
Requested – Oklahoma Matching Fund	\$1,687,630

This project directly supports the goals of the Oklahoma Disaster Mitigation and Recovery Matching Fund Program by leveraging federal funds, reducing hazard exposure, protecting public infrastructure, and increasing long-term community resilience. It also addresses one or more qualifying hazards under the program, including flooding, severe rainfall events, and infrastructure damage caused by stormwater overflow.

The City of Chickasha is committed to providing all documentation necessary to support the OKGrants application, including project descriptions, budget details, verification of leverage, and any additional materials required by ASCOG or the Oklahoma Department of Commerce. If awarded, the City is committed to working collaboratively with ASCOG and all state and federal partners to complete final design, advance the project to shovel-ready status, and pursue future construction funding.

Thank you for your consideration of this request and for your continued support of disaster mitigation efforts across Oklahoma.

Sincerely,

Jim Crosby

City Manager

City of Chickasha, Oklahoma

Phone: (405) 222-6045

Email: Jim.Crosby@Chickasha.gov

City of Chickasha

117 North 4th Street, Chickasha, OK 73018 • 405-222-6045 Jim.Crosby@chickasha.org

The City of Chickasha is an equal opportunity employer and provider. For TDD/TTY assistance, please dial 711.

Line Creek Flood Mitigation Project

Executive Project Briefing

City of Chickasha, Oklahoma | Office of Emergency Management | Edward Perez, Director | April 27, 2026

Purpose. This briefing presents the engineering analysis, flood modeling results, and funding pathway for the Line Creek channel and bridge improvement project in Chickasha, Oklahoma. WSB Engineering has determined that a defined, cost-effective solution exists with a preliminary positive benefit-cost ratio that can be advanced through the reinstated FY24/FY25 BRIC funding opportunity.

⚠️ ACTION DEADLINE: Oklahoma OEM subapplication due June 12, 2026 — 46 days from today.

Oklahoma OEM requires subapplications by **June 12, 2026** — six weeks earlier than the federal FEMA GO deadline of July 23, 2026. This is the binding deadline for Chickasha. Contact Oklahoma OEM Hazard Mitigation at hm@oem.ok.gov to begin coordination now. Previous subapplications submitted under the initial FY2024 NOFO (January 2025) will not be reviewed; this is a new application.

BENEFIT-COST RATIO	50-YEAR DAMAGES AVOIDED	EXISTING ANNUAL DAMAGES	POST-PROJECT ANNUAL DAMAGES
1.20	\$75.37M	\$6.81M	\$1.34M
Benefits exceed cost	Present-value reduction	Average annual damages	Average annual damages

Executive bottom line

The immediate decision is not whether to build a \$63 million construction project today. The immediate decision is whether Chickasha should use the current BRIC opportunity to pay for the design work needed to keep the project moving toward construction eligibility.

The cost of inaction is concrete: Chickasha absorbs an estimated **\$6.81 million in average annual flood damages** under existing conditions. Based on the City of Chickasha’s FY25-26 proposed General Fund, this figure equals roughly **one-third of Chickasha’s entire General Fund revenue** absorbed by the community each year in flood losses. Completing design now, at a local match cost of \$1.69M, is the prerequisite to ever eliminating that recurring loss.

Figure 1 - Beginning condition vs. final improvement result

Beginning condition: Existing 100-year flood model **End result: Final project improvements**

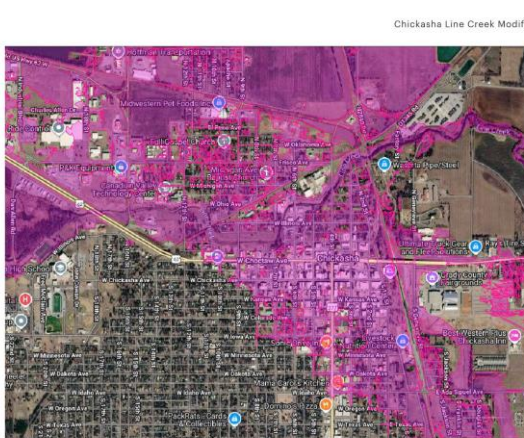

Figure 1: Existing 100-year Maximum Water Surface Elevation (WSE)

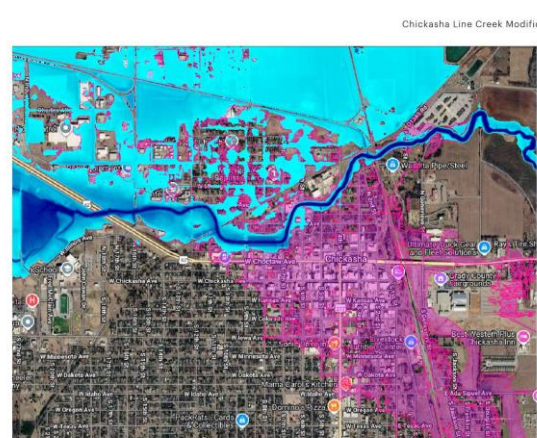

Figure 4: 100-year Maximum Depth of Flood - Final Project Improvements versus Existing 100-year Max. WSE

Figure 1: Existing 100-year Maximum Water Surface Elevation — Pink shading shows the current 100-year floodplain extent across Chickasha’s downtown and business district.

Figure 4: Final Project Improvements — Pink areas show the dramatically reduced 100-year floodplain after all four city bridge replacements and full channel modifications are complete.

<p>1,257 structures affected 3,268 population at risk \$6,805,965 average annual flood damages \$93,927,400 50-year damages PV</p>	<p>798 structures protected 2,075 people protected \$1,344,950 average annual flood damages \$18,561,320 post-project damages PV</p>
Existing modeling shows substantial flood exposure in the downtown and business district tied to Line Creek conveyance limitations.	Final modeling shows substantial reduction in the floodplain footprint when bridge improvements are combined with channel modifications.

Figure 2 - Modeled reduction summary

Measure	Existing	Final modeled result	Improvement
Structures	1,257 affected	459 remaining affected	798 protected
Population	3,268 at risk	1,193 remaining at risk	2,075 protected
Annual damages	\$6,805,965	\$1,344,950	\$5,461,015 reduced annually
50-year PV damages	\$93,927,400	\$18,561,320	\$75,366,080 avoided

Figure 3 - Flood model maps: existing conditions and phased improvements

The following maps show modeled 100-year flood conditions under existing conditions and after each phase of proposed improvements. Maps show the maximum depth of flooding relative to the existing 100-year water surface elevation. Pink shading represents areas that are still flooded; blue/cyan shading represents areas where flooding is reduced compared to existing conditions. The full project build-out (all four city bridges replaced and full channel modifications) is required to achieve the substantial, citywide reduction shown in Map 4.

Map 1: Existing Conditions Map 2: Post-Phase 1 Improvements

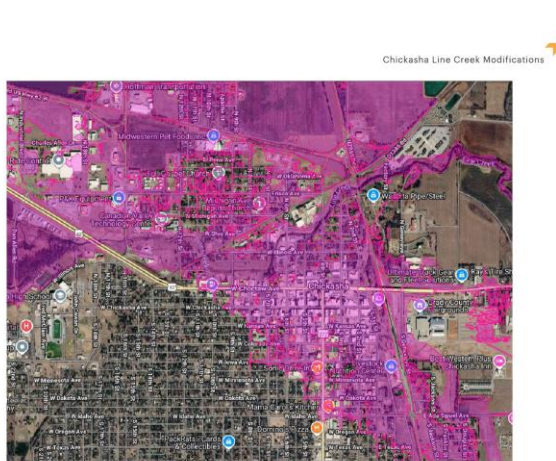

Figure 1: Existing 100-year Maximum Water Surface Elevation (WSE)

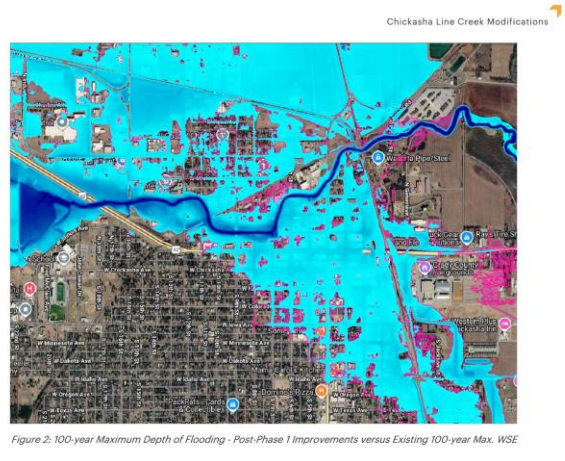

Figure 2: 100-year Maximum Depth of Flooding - Post-Phase 1 Improvements versus Existing 100-year Max. WSE

100-year floodplain under existing conditions. Pink shading covers large portions of Chickasha’s downtown and business district, with average annual damages of \$6.81M.

Phase 1: downstream improvements from Rock Island Railroad bridge to Washita flood fringe, including Factory Street bridge replacement. Blue areas show marginal reduction in flood depths — meaningful relief requires the full project.

Map 3: Post-Phase 2 Improvements Map 4: Full Project (Final Result)

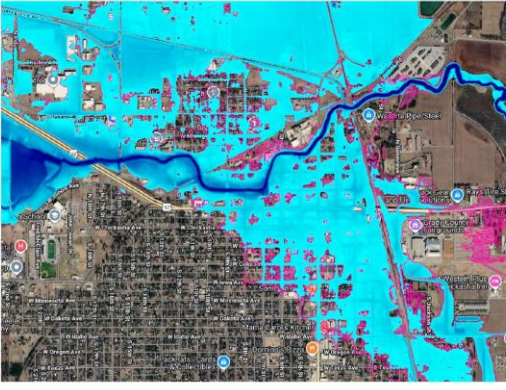

Figure 3: 100-year Maximum Depth of Flooding - Post-Phase 2 Improvements versus Existing 100-year Max. WSE

3

Phase 2: extends improvements from 4th–6th Streets downstream, adding 4th Street bridge replacement. Still marginal improvement citywide — upstream restrictions continue to limit flood relief until the full project is in place.

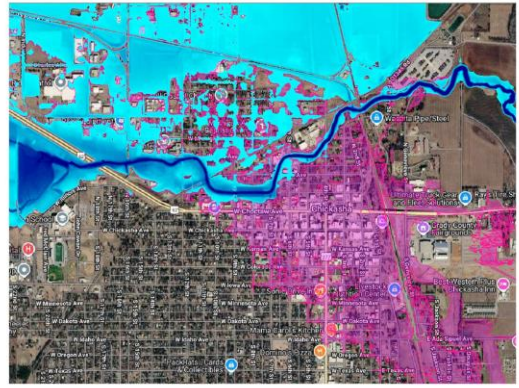

Figure 4: 100-year Maximum Depth of Flood - Final Project Improvements versus Existing 100-year Max. WSE

4

Full project: all four city bridges replaced and complete channel modifications. Pink shading is dramatically reduced — 798 structures protected, annual damages reduced from \$6.81M to \$1.34M, and the 100-year floodplain retreats substantially from the downtown core.

WSB engineering findings

- The recurrent flooding in Chickasha's downtown and business district is mainly attributable to conveyance limitations along the one-mile reach of Line Creek south of the Stillwater Central Railroad line.
- The greatest reduction in flood depths requires bridge replacement combined with channel bank and vertical geometry modifications. Bridge replacement alone provides limited benefit.
- The channel is generally natural and unlined, with a bottom approximately 30 feet wide and bank heights ranging from approximately 10 to 20 feet.
- Analysis identifies a strong benefit case: a \$75.37 million present-value reduction in flood damages compared to a \$63.00 million project cost.
- WSB recommends submitting an application under the current BRIC NOFO because design is the required step that moves the project toward shovel-ready status.

Grant pathway and design costs

WSB Engineering has prepared a 100% Project Design application under the BRIC Capability- and Capacity-Building (C&CB) category. Completing full project design is the required step before construction funding can be pursued in a future grant cycle.

Application scenario	Total eligible cost	Federal share (75%)	Local share (25%)
100% Design Application	\$6,750,522	\$5,062,892	\$1,687,630

Why the preliminary 1.20 benefit-cost ratio is a floor, not a ceiling

WSB’s April 24, 2026 model results (Slide 6) identify four refinements that have not yet been incorporated into the current BCA. Each of these, when finalized, is expected to **increase** the benefit-cost ratio above 1.20. The current analysis uses: (1) assessed value rather than replacement cost for structures, replacement cost is typically higher, meaning actual flood damages are higher than modeled; (2) a conservative structure classification that may undercount eligible structures; and (3) \$0 for both social benefits and environmental benefits. Once these pending refinements are included, the BCR will be stronger. The preliminary 1.20 ratio already clears FEMA’s cost-effectiveness threshold; a refined analysis will create more competitive separation from that threshold.

Grant competition context

The FY24/25 NOFO combines two years of funding into a single competitive round, making it the largest BRIC opportunity in the program’s history. Several factors bear directly on Chickasha’s position:

- **National Competition pool is \$757 million** with a \$20 million per-project cap. This project’s design application (\$6.75M total, \$5.06M federal share) fits well within that cap and competes in the national pool, not Oklahoma’s \$2M state allocation, which is too small to fund this project.
- **Construction readiness is scored.** FEMA’s FY24/25 evaluation criteria include a sliding scale that awards points based on percent design completed when applying for construction funding. Pursuing 100% design now means future construction applications receive maximum readiness points, a direct competitive advantage over communities still at the scoping stage.
- **This cycle will be more competitive than typical years.** The combined FY24+FY25 pool will attract applications that were held in reserve from the cancelled January 2025 NOFO. A complete, well-documented application with a BCA above 1.0 and clear infrastructure scope is essential. This project has both.
- **FEMA’s renewed focus aligns with this project.** FEMA’s new direction explicitly prioritizes “infrastructure-related hazard mitigation projects” that deliver direct risk reduction to people and property. Bridge replacement and channel modification is exactly the category BRIC is now designed to fund.

Construction cost and benefit-cost summary

Item	Value	Briefing meaning
Preliminary construction cost	\$63,004,874	Current opinion of probable construction cost
Full design estimate	\$6,750,522	100% design pathway
Existing damages PV	\$93,927,400	50-year present value of modeled damages without action
Proposed damages PV	\$18,561,320	50-year present value after final improvements
Net benefits	\$75,366,080	Avoided damages over 50 years
Benefit-Cost Ratio	1.20	Qualifies as cost-effective under federal grant screening

What design funding includes:

- Topographic surveying and technical data collection.
- Right-of-way planning and acquisition support.
- Geotechnical investigations to support bridge and channel design.
- Permitting and compliance work, including NEPA, Section 404, and Section 106 requirements.
- Structural engineering for proposed bridge replacements.
- Engineering plans for channel modifications, bank stabilization, and mitigation of head-cut migration.
- Refined cost estimates and FEMA-compliant Benefit-Cost Analysis required for future construction funding.

Recommended action

Submit the 100% Project Design application under the current BRIC NOFO. At a local match of \$1,687,630 (25% of eligible design costs), this pathway delivers fully bid-ready plans and positions the project for maximum competitiveness in future construction grant cycles. It is the strongest single step available to move this project toward construction.

Recommended design pathway

100% Project Design Application

Local match required: \$1,687,630

Delivers 100% bid-ready design documents and construction-level cost estimate

Produces FEMA-compliant Benefit-Cost Analysis required for future construction funding

Maximum competitive positioning for future BRIC or HMGP construction grant cycles

Advances project to shovel-ready status

Sources: WSB Project Summary, signed April 27, 2026; Chickasha Current Model Results, April 24, 2026; WSB Preliminary Opinion of Probable Costs, April 24, 2026; WSB Line Creek Flood Mitigation Executive Briefing, April 27, 2026. Grant program: FEMA FY2024–2025 BRIC Notice of Funding Opportunity, issued March 25, 2026 (fema.gov/grants/mitigation/learn/building-resilient-infrastructure-and-communities); FEMA BRIC NOFO Fact Sheet, March 2026 (fema.gov/sites/default/files/documents/fema_hma_bric-nofo-fact-sheet_fy24-fy25.pdf). Oklahoma-specific deadlines and guidance: Oklahoma OEM BRIC Program page (oklahoma.gov/oem/programs-and-services/mitigation/bric.html); Oklahoma OEM April 2026 Newsletter (oklahoma.gov/oem/news/newsroom/april-2026-newsletter.html) — confirming Oklahoma subapplication deadline of June 12, 2026. Fiscal context: City of Chickasha FY25-26 Proposed General Fund Budget, May 29, 2025 (chickasha.org). Program analysis: ICF, “FEMA BRIC Restart: What It Means for Resilience Funding,” March 2026 (icf.com). Congressional Research Service, BRIC Developments Insight IN12609, 2026 (congress.gov). BCR pending refinements sourced from WSB Chickasha Current Model Results, Slide 6 (“Pending Refinements”), April 24, 2026.

Oklahoma Disaster Mitigation and Recovery Matching Fund Program

Application Guidance



**The Oklahoma Department of Commerce
Community Development Division**
Effective date: July 2025

Table of Contents

- Introduction.....3
 - 1.1 Purpose..... 3
 - 1.2 Responsibility 3
 - 1.3 Eligible Applicants..... 3
 - 1.4 Method of Distribution 3
 - 1.5 Use of Funds 3
 - 1.6 Ineligible Uses of Funds 3
- How to Apply.....4
 - 1.1 Application Website..... 4
 - 1.2 Required Documentation for the OKGrants Application 4
 - 1.2.1 Item 1: Application Summary and Certification..... 4
 - 1.2.2 Item 2: Detailed Line-Item Budget..... 4
 - 1.2.3 Item 3: Audit..... 4
 - 1.2.4 Item 5: W-9..... 4
 - 1.2.5 Item 6: Verification of Leverage..... 4
 - 1.2.6 Item 7: Project Description 4
- ODOC Contact Information.....5

Introduction

1.1 Purpose

The *Oklahoma Disaster Mitigation and Recovery Matching Fund Program* (ODMRMF) was created to provide dedicated state funding to help local governments and related entities secure and maximize federal disaster mitigation and recovery funds.

1.2 Responsibility

The Oklahoma Department of Commerce (ODOC) administers the ODMRMF. The funding for this program is provided by the State Treasury but managed and overseen by ODOC. ODOC is responsible for ensuring the proper allocation, tracking, and oversight of funds, prescribing reporting formats, and maintaining public access to expenditure summaries through its website.

1.3 Eligible Applicants

Eligible applicants are Substate Planning Districts (SSPDs) or Councils of Government (COGs) identified below.

ACOG	ASCOG	COEDD	EODD
GGEDA	INCOG	KEDDO	NODA
OEDA	SODA	SWODA	

1.4 Method of Distribution

Awards will be distributed based on funding availability at the time of application. ODOC has the discretion to approve projects in amounts as we see fit for the best interest of the State. ODOC will make awards on a first-come, first-served basis until funds have been exhausted.

1.5 Use of Funds

Funds for ODMRMF must be used as leverage for federal grants for the prevention of damage or to repair damage caused by a qualifying hazard, manmade disaster, or other hazardous condition, which includes but is not limited to the following:

High Winds	Tornadoes	Hail
Rain	Flooding	Freezing Rain or Ice
Heavy Snow	Wildfires	Seismic Disturbance

1.6 Ineligible Uses of Funds

The funds **must not** be used for direct expenditures on salaries, employee benefits, or the acquisition of real or personal property.

How to Apply

1.1 Application Website

Eligible applicants are required to apply through OKGrants ([website link](#)).

1.2 Required Documentation for the OKGrants Application

1.2.1 Item 1: Application Summary and Certification

The Application Summary and Certification is an online form within the OKGrants system. The certification verifies the accuracy and completeness of the application.

1.2.2 Item 2: Detailed Line-Item Budget

The Detailed Line-Item Budget is an online form in the OKGrants system. The proposed activities should be as specific as possible, as they will form the basis of your contract and project budget should you receive funding.

1.2.3 Item 3: Audit

All applicants must submit a current audit pursuant to [Oklahoma Administrative Code Title 150 Chapter 1 Subchapter 21](#).

1.2.4 Item 5: W-9

This form must be completed and submitted to OKGrants. The W-9 form (Taxpayer Identification Number & Certification) must be filled out and uploaded as part of the application process.

1.2.5 Item 6: Verification of Leverage

This form must be completed and submitted in OKGrants to identify the federal funds that will be used in conjunction with ODMRMF.

1.2.6 Item 7: Project Description

Applicants are required to submit a Project Description that describes the use of funds. The document must contain the following elements:

Title Page

Agency logo, submittal date, and contact information.

Narrative

Description of the proposal.

Project Contacts

Provide the project contacts for the applicant submitting the proposal. Additionally, provide contacts for the community applying for the use of these funds as a match.

Budget Table

Identify all leverage sources of funding in addition to this request.

Map

Provide one to three maps that describe the location of the project(s).

ODOC Contact Information

Questions regarding this application guidance should be directed to one of the following individuals:

Marshall Vogts (marshall.vogts@okcommerce.gov)

Kellon Dixon (kellon.dixon@okcommerce.gov)

Jade Shain (jade.shain@okcommerce.gov)

CHICKASHA

Meeting Type: CMA Agenda 5-4-2026

Meeting Date: 5/4/2026

Department: Administration

Agenda Item No. 4.d.

AGENDA ITEM: Discussion, consideration, and possible action to approve a License Agreement between the Chickasha Municipal Authority and Stillwater Central Railroad, L.L.C. for an underground pipeline crossing and existing waterline facilities within railroad right-of-way in connection with the Authority’s water system improvements project, including approval of associated fees, and authorization of the Chairman to execute the agreement.

I. BACKGROUND/DESCRIPTION:

II. RECOMMENDED ACTION:

Approve a License Agreement between the Chickasha Municipal Authority and Stillwater Central Railroad, L.L.C. for an underground pipeline crossing and existing waterline facilities within railroad right-of-way in connection with the Authority’s water system improvements project, including approval of associated fees, and authorization of the Chairman to execute the agreement.

III. FISCAL INFORMATION -

IV. FUND INFORMATION:

Dept. Director: Jim Crosby, City Manager	Fund	Account	Amount
	(To)		
	FUND	ACCOUNT	AMOUNT
Meeting Date: May 4, 2026	(From)		

V. ATTACHMENTS:

1. SLWC530792 - Agreement - for wet signature by City of Chickasha

STILLWATER CENTRAL RAILROAD, L.L.C.

LICENSE AGREEMENT FOR WIRE, PIPE AND CABLE TRANSVERSE CROSSINGS AND LONGITUDINAL OCCUPATIONS

THIS AGREEMENT, made and entered into _____, between **STILLWATER CENTRAL RAILROAD, L.L.C.**, which has a mailing address at 315 West 3rd Street, Pittsburg, Kansas 66762, party of the first part (hereinafter called "Railroad"), and the **CHICKASHA MUNICIPAL AUTHORITY** having a mailing address at 117 N 4th Street Chickasha, Oklahoma 73018, as party of the second part (hereinafter called "Licensee").

WHEREAS, Licensee operates an existing underground longitudinal pipeline consisting of one (1) 18-inch ductile iron water pipeline running longitudinal to the tracks within railroad right-of-way for approximately 2,160 linear feet from Mile Post 580.13 to Mile Post 580.56 and an underground transverse pipeline crossing consisting of one (1) 18-inch ductile iron water pipeline encased within a 28-inch steel pipe at Mile Post 580.15, at or near Chickasha, Grady County, Oklahoma; and

WHEREAS, Licensee proposes to install an underground transverse pipeline crossing consisting of one (1) 26-inch ductile iron water pipeline encased within a 36-inch steel pipe at Mile Post 580.17; and

WHEREAS, Railroad is agreeable to such planned work; and

WHEREAS, this Agreement is intended to cover the existing pipelines in place prior to the effective date of this Agreement as well as new construction; and

WHEREAS, Licensee and Railroad agree, subject to the terms hereof, to enter into a License Agreement for the protection of the property and rights of both parties;

NOW THEREFORE, in consideration of the mutual covenants, terms, and conditions herein contained, it is agreed as follows:

WITNESSETH, that said Railroad (which when used herein shall include any licensor, lessor, successor or assignee of or operator over its railroad) insofar as it has the legal right to do so, without warranty and subject to all encumbrances, covenants and easements to which the Railroad's title may be subject, and in consideration of the covenants and conditions hereinafter stated on the part of Licensee to be kept and performed, hereby permits, as a temporary license, Licensee to construct, maintain, repair, alter, renew, relocate and ultimately remove:

Licensee has submitted to Railroad an Application related to the proposed installation and construction of a new underground transverse pipeline crossing consisting of one (1) 26-inch ductile iron water pipeline encased within a 36-inch steel pipe at Mile Post 580.17 added to existing facilities comprised of one (1) 18-inch longitudinal water pipeline within railroad right-of-way for 2,160 linear feet and one (1) 18-inch water pipeline encased within a 28-inch steel pipe crossing at Mile Post 580.15, at or near Chickasha, Grady County, OK.

the same to be located in accordance with and limited to the installation shown on the diagram set forth in **EXHIBIT "A"** attached hereto and made part hereof (such right-of-way or property of Railroad).

Railroad hereby grants to Licensee, insofar as Railroad has the right to do so, in accordance with engineering plans, submitted by Licensee to and approved by the Railroad's Chief Engineer or his or her authorized representative, incorporated herein by reference, all and any part thereof being hereinafter referred to as the "FACILITIES"; said license, however, shall be under and subject to the following terms, covenants and conditions as hereinafter recited, which are hereby accepted and agreed to, by Licensee, to wit:

1. The Licensee shall pay to Railroad upon the execution hereof, the sum of \$1,750.00 as a one-time document processing fee and an annual license fee of \$1,500.00 on April 1st for the term of the Agreement, beginning upon execution hereof for the period 04/01/2026 through 03/31/2027 (annual fees to be adjusted as follows). Railroad reserves the right to make adjustments in these charges.

The annual license fee specified above shall be adjusted annually (beginning with the payment due 03/01/2027) and shall be changed by the greater of (i) 3% or (ii) the percentage increase as reflected in the "Consumer Price Index for Urban Wage Earners and Clerical Workers (CPI-W) (1967=100)" specified for "All Items - United States" compiled by the Bureau of Labor Statistics of the United States Department of Labor (the "Index") as described below.

If applicable, the current base rent payable shall be changed in accordance with the following:

- (a) The current base rent shall be adjusted annually, commencing 04/01/2027.
- (b) Each adjustment shall be made with reference to the price index for the second month immediately preceding the effective date of each adjustment (Current Price Index).
- (c) Each such adjustment shall be made by determining the percentage change of the then Current Price Index over the price Index for the full calendar month of April 2026 ("Base Price Index").
- (d) Such percentage shall be computed by (i) obtaining the difference between the Current Price Index and the Base Price Index and (ii) dividing such difference by the Base Price Index.
- (e) The percentage thus determined shall be multiplied by the then applicable current base rent hereinabove set forth, and the product thus determined shall represent the change payable in addition to the current base rent until a subsequent adjustment shall be made under this section.

In the event the Index shall hereafter be converted to a different standard of reference base or otherwise revised, the determination of the percentage change shall be made with the use of such conversion factor, formula, or table for converting the Index as may be published by the Bureau of Labor Statistics or, if said Bureau shall not publish the same, then as shall be reasonably determined by Railroad. Railroad shall provide prior notice to Licensee of all increases in rent and, upon request from Licensee, shall provide the calculation used to determine the current base rent.

2. (a) Licensee shall, at its expense, construct and maintain in exact accordance with said construction plans and for the purpose as outlined in Page 1. No departure shall be made at any time there from except upon prior written permission granted by the Railroad's Chief Engineer or his or her authorized representative, provided, however, that if any commission or other regulatory body duly constituted and appointed in compliance with the laws of the State in which the installation or occupancy herein provided is situated, and having jurisdiction in the premises, has by ruling or other general order determined and fixed the manner and means of construction,

maintenance, repair, alteration, renewal, relocation or removal thereof, then said ruling or general order shall prevail for the crossing or occupancy herein mentioned.

(b) The work of constructing, maintaining, repairing, altering, renewing, relocating or removing the said Facilities shall be done under such general conditions as will be satisfactory to and approved by the Railroad's Chief Engineer or his or her authorized representative, and as will not interfere with the operations of the Railroad, endanger persons or property of Railroad, or interfere with the enjoyment of the property of Railroad. With respect to each operations project that requires access to the Premises, Railroad shall, at Railroad's option, furnish, at the sole expense of Licensee, any necessary inspectors, flagmen or watchmen to see that personnel, equipment and materials are kept a safe distance away from the tracks of Railroad, to support Railroad's tracks and to protect Railroad's traffic.

(c) In addition to, but not in limitation of any of the foregoing provisions, if at any time, at Railroad's option, should deem inspectors, observers, monitors, flagmen or watchmen desirable or necessary to protect its operations or property, or its employees, patrons or Licensees during the work of construction, maintenance, repair, alteration, renewal, relocation or removal of said Facilities, of Licensee, Railroad shall have the right to place such inspectors, observers, monitors, flagmen, or watchmen at the sole risk, cost and expense of Licensee, which covenants and agrees to bear the full cost and expense thereof and to promptly reimburse Railroad upon demand. The furnishing or failure to furnish inspectors, flagmen, or watchmen by Railroad, however, shall not release Licensee from any and all other liabilities assumed by Licensee under the terms of this Agreement. Furthermore, Railroad may require Licensee and/or its Contractor to secure construction observation through Railroad's approved observer named below during all construction and installation work. Licensee is to directly contact and coordinate services with Railroad's approved observer.

RailPros Field Services

Email: Watco.Utility@railpros.com

Copy: Utilities.office.staff@railpros.com

682-223-5271

3. Licensee shall enter the Premises in any given instance only pursuant to an approved Application. Prior to commencement of any work to be performed on or about the Premises, Licensee shall notify the appropriate Railroad General Manager or their authorized representative for the scheduling of protection services. Within seventy-two (72) hours after the General Manager's actual receipt of such notification, the General Manager shall review the necessity and availability of flagman or other protection services for the proposed work and advise Licensee of such matters and the estimated cost of protection services. No work shall be permitted on or about the Premises without the presence of Railroad's protection services or the General Manager's waiver of the requirement for protection services. Entry on or about the Premises or any other Railroad's right-of-way without the General Manager's prior approval shall be deemed trespassing. Licensee agrees to pay Railroad, within thirty (30) days after delivery of an invoice, for the cost of protection services provided by or on the behalf of Railroad.
4. The Premises shall be used by Licensee only for the operations of the Facilities and for no other purposes. Licensee accepts the Premises in their current "as is" condition, as suited for operations, and without the benefit of any improvements to be constructed by Railroad. If Licensee desires or is required, as herein provided, to revise, renew, add to or alter in any manner whatsoever the aforementioned Facilities, it shall submit an application with plans conforming to Railroad's then-current standards and procedures and obtain the written approval of the Railroad's Chief Engineer

or his or her authorized representative thereto before any work or alteration of the facility is performed and the terms and conditions of this Agreement with respect to the original construction shall apply thereto. Railroad reserves the right to make adjustments in the rental charges.

5. (a) Licensee shall at all times be obligated to promptly maintain, repair, reinforce and renew said Facilities; and shall, upon notice from Railroad requiring it so to do, promptly make such repairs and renewals thereto as may be required by Railroad; or Railroad, for the purpose of protecting and safeguarding its property, traffic, patrons or employees from damage or injury, may with or without notice to Licensee at any time make such repairs and renewals there to and furnish such material therefore as it deems adequate and necessary all at the sole cost and expense of Licensee.

(b) In the event of an emergency, Licensee will take immediate steps to perform any necessary repairs, and in the event, Licensee fails so to do, Railroad will perform said necessary repairs at the sole cost and expense of Licensee.
6. (a) The supervision over the location of the construction work and inspection of the Facilities and the approval of the material used in construction, maintenance, repair, alteration, renewal, relocation and removal of the aforesaid Facilities covered by this Agreement shall be within the jurisdictional rights of Railroad.

(b) The right of supervision over the location of the construction work and inspection of the Facilities from time to time thereafter by Railroad, shall extend for an appropriate distance on each side of the property of Railroad as the method of construction and materials used may have an important bearing upon the strength and stability of the Facilities over, under, upon or in the property of Railroad.
7. Licensee shall comply with all Federal, State and Local laws, and assume all cost and expense and responsibility in connection therewith, without any liability whatsoever on the part of the Railroad.
8. (a) It is understood between the parties hereto that the operations of Railroad at or near the Facilities involve some risk, and Licensee as part of the consideration for this license hereby releases and waives any right to ask for or demand damages for or account of loss of or injury to the Facilities (and contents thereof) of Licensee that are over, under, upon or in the property and facilities of Railroad including the loss of or interference with service or use thereof and whether attributable to the fault, failure or negligence of Railroad or otherwise.

(b) And Licensee also covenants and agrees to and shall at all times indemnify, protect and save harmless Railroad from and against all cost or expense resulting from any and all losses, damages, detriments, suits, claims, demands, costs and charges which the said Railroad may directly or indirectly suffer, sustain or be subjected to by reason or on account of the construction, placement, attachment, presence, use, maintenance, repair, alteration, renewal, relocation or removal of said Facilities in, on, about or from the premises of Railroad whether such losses and damages be suffered or sustained by Railroad directly or by its employees, patrons or licensees, or be suffered or sustained by other persons or corporations, including Licensee, its employees and agents who may seek to hold Railroad liable therefore, and whether attributable to the fault, failure or negligence of Railroad or otherwise, except when proved by Licensee to be due directly to the sole negligence of Railroad. **IRRESPECTIVE OF THE ABOVE AND REGARDLESS OF THE FAULT OF RAILROAD, UNDER NO CIRCUMSTANCES SHALL RAILROAD HAVE ANY LIABILITY TO THE OTHER PARTY, THEIR EMPLOYEES, AGENTS, REPRESENTATIVES, OR THIRD PARTY FOR ANY CONSEQUENTIAL,**

INCIDENTAL, OR OTHER INDIRECT LOSS OR DAMAGES, PUNITIVE, OR EXEMPLARY DAMAGES OR COSTS HOWSOEVER CAUSED ON ACCOUNT OF THE CONSTRUCTION, PLACEMENT, ATTACHMENT, PRESENCE, USE, MAINTENANCE, REPAIR, ALTERATION, RENEWAL, RELOCATION OR REMOVAL OF SAID FACILITIES IN, ON, ABOUT OR FROM THE PREMISES OF RAILROAD DESCRIBED HEREIN AND LICENSEE SHALL INDEMNIFY AND HOLD HARMLESS RAILROAD FROM THE SAME.

- (c) If a claim or action is brought against either party and for which the other party may be responsible hereunder in whole or in part, such other party shall be notified and permitted to participate in the handling or defense of such matter.
9. All cost and expenses in connection with the operation, construction, maintenance, repair, alteration, renewal, relocation and removal of said Facilities shall be borne by Licensee, and in the event of work being performed or material furnished by Railroad under the stipulated right to perform such work of construction, maintenance, repair, alteration, renewal, relocation or removal under any section hereof, Licensee agrees to pay to Railroad the actual cost of material plus the current applicable overhead percentages for storage, handling, transportation, purchasing and other related material management expenses and the actual cost of labor plus the current applicable overhead percentages as developed and published by the accounting department of Railroad for fringe benefits, payroll taxes, administration, supervision, use of tools, machinery and other equipment, supplies, employers liability insurance, public liability insurance and other insurance, taxes and all other indirect expenses. It is to be understood that the aforementioned material and labor overhead charges are to be applied at the rates which are effective at the time of the performance of any work by employees of Railroad on the said Facilities. Licensee agrees to pay such bills within thirty (30) days of the presentation thereof by Railroad.
 10. Licensee shall, at its sole cost and expense, upon thirty (30) days prior written notice from Railroad, promptly change the location of said Facilities covered by this Agreement, where located over, under, upon and along, or in the property and facilities of Railroad, to another location, to permit and accommodate changes of grade or alignment and improvement in or additions to the facilities of Railroad upon land now or hereafter owned or used by Railroad to the intent that said construction shall at all times comply with the terms and conditions of this Agreement with respect to the original construction; or in the event of the lease, sale or disposal of the premises or any part thereof encumbered by this license, then said Licensee shall make such adjustments or relocations in its Facilities as are over, under, upon and along or in the property and facilities of Railroad as may be required by said Railroad or its grantee; and if Licensee shall fail or refuse to comply therewith, then the duly authorized agents of Railroad may make such repairs or adjustments or changes in location and provide necessary material therefore.
 11. In the event the Facilities consist of an underground occupation, Licensee will be responsible for any settlement caused to the roadbed, right of way and/or tracks, facilities and appurtenances of Railroad arising from or as a result of the installation of the said Facilities for a period of one (1) year subsequent to the date of completion of the installation, and Licensee agrees to pay to Railroad on demand the full cost and expense, therefore.
 12. If the Facilities cause degradation of Railroad's signal, communications and other electronic systems or endanger Railroad's personnel or other individuals entitled to be on or about the Premises, through inductive or electrostatic interference or otherwise, Licensee, at its expense shall immediately remedy any inductive interference to the satisfaction of Railroad growing out of or resulting from the presence of its Facilities; and if Licensee should fail so to do, then Railroad may

take any/all corrective measures deemed necessary. The provisions of this Section 12 shall apply to the Electronic Systems existing as of the date of this Agreement and to any Electronic Systems that Railroad may install in the future.

13. If Licensee fails to take any corrective measures requested by Railroad in a timely manner, or if an emergency situation is presented which, in Railroad's sole judgement, requires immediate repairs to the Facilities, Railroad, at Licensee's expense, may undertake such corrective measures or repairs as it deems necessary or desirable.
14. As part of the consideration of the within Agreement, Licensee covenants and agrees that no assessments, taxes or charges of any kind shall be made against Railroad or its property by reason of the construction of said Facilities of Licensee, and Licensee further covenants and agrees to pay to Railroad promptly upon bills rendered therefore the full amount of any assessments, taxes or charges of any kind which may be levied, charged, assessed or imposed against Railroad or its property by reason of the construction and maintenance of said Facilities of Licensee.
15.
 - (a) The rights conferred hereby shall be the privilege of Licensee only, and Licensee shall not assign, transfer, sell, mortgage, encumber, sublease or otherwise convey (whether voluntarily, or involuntarily or by operation of law) this Agreement or any interest therein, nor license, mortgage, encumber or otherwise grant to any other person or entity (whether voluntarily, involuntarily or by operation of law) any right of privilege in or to the Premises (or any interest therein), in whole or in part, without the prior written consent of Railroad, which consent may be withheld by Railroad in its sole discretion. Any such assignment or other transfer made without Railroad's prior written consent shall be null and void and, at Railroad's option, shall constitute an immediate default of this Agreement. Notwithstanding the foregoing, upon prior written notice to Railroad, Licensee may assign this Agreement to a wholly owned subsidiary of Licensee's parent without Railroad's consent; provided, however, that no such assignment shall relieve Licensee of its obligations under this Agreement.
 - (b) Railroad shall have the right to transfer and assign, in whole or in part, all its rights and obligations hereunder and in or to the Premises. From and after the effective date of any such assignment or transfer, Railroad shall be released from any further obligations hereunder; and Licensee shall look solely to such successor-in-interest of Railroad for the performance of the obligations of "Railroad" hereunder.
16. This Agreement shall take effect after signed by both parties. This Agreement will automatically renew for one (1) year terms thereafter if neither party submits in writing the desire to terminate.
17.
 - (a) This Agreement with the rights granted may be terminated at any time by either party hereto upon not less than thirty (30) days' written notice to the other; and upon the expiration of the said thirty (30) days after service of such notice, this Agreement and the permission and privileges hereby granted shall absolutely cease and terminate.
 - (b) The Facilities are and shall remain the personal property of Licensee. Prior to the expiration or termination of this Agreement, Licensee shall remove the Facilities from the Premises after receiving written approval from the Railroad. In performing such removal, unless otherwise directed by Railroad, Licensee shall restore the Premises to the same condition as existed prior to the installation or placement of Facilities, reasonable wear and tear excepted. In the event Licensee shall fail to so remove the Facilities or restore the Premises, the Facilities shall be deemed to have been abandoned by Licensee, and the same shall become the property of Railroad for Railroad to use, remove, destroy or otherwise dispose of at its discretion and without responsibility for

accounting to Licensee therefor; provided, however, in the event Railroad elects to remove the Facilities, Railroad, in addition to any other legal remedy it may have, shall have the right to recover from Licensee all costs incurred in connection with such removal and the restoration of the Premises. Notwithstanding anything to the contrary contained in this Agreement, the expiration or termination of this Agreement, whether by lapse of time or otherwise, shall not relieve Licensee from Licensee's obligations accruing prior to the expiration or termination date, and such obligations shall survive any such expiration or other termination of this Agreement.

(c) If Licensee shall fail to install the Facilities within one (1) year from the date of the Agreement, or if Licensee shall discontinue the use or operation of the Facilities for one (1) year. Railroad may, at its sole discretion, terminate this Agreement by written notice to Licensee.

18. Automobile mileage charges incurred by aforementioned Railroad inspectors, flagmen or watchmen in connection with the installation, maintenance, etc., of said Facilities will be based on allowances approved by the United States Government in effect at the time the expenses are incurred.

19. Environmental Compliance

19.1 Licensee represents that it has conducted a complete inspection of the Facilities and except as noted herein, finds the Facilities to be reasonably free from pollution-induced conditions.

19.2 Licensee assumes all responsibility for any environmental obligations imposed under applicable laws, regulations, ordinances or other requirements of federal, state and local governmental authorities relating to (a) any operations, including notification and reporting of any releases, and (b) any contamination of any property, water, air, or groundwater arising or resulting, in whole or in part, from Licensee's operations or use the Premises pursuant to this Agreement. Licensee agrees to indemnify and hold harmless Railroad from and against any and all fines, penalties, demands or other Losses (including attorneys' fees) incurred by Railroad or claimed by any person, company or governmental entity relating to (a) any contamination of any property, water, air or grand water due to the use or presence of the Facilities on the Premises, (b) Licensee's violation of any laws, regulations or other requirements of federal, state or local governmental authorities in connection with the use or presence of the Facilities on the Premises, or (c) any violation of Licensee's obligations.

19.3 Without limiting any other provisions of this Agreement, Licensee, at its expense, will at all times maintain and keep the Facilities and all improvements and property now or hereafter erected or placed thereon, including but not limited to, the structures, equipment, and operations, in compliance with all federal, state, and local laws, rules and regulations designed to prevent or control the discharge of substances in the land, water, or air, and Licensee agrees to indemnify, hold harmless and defend Railroad from and against any and all fines, penalties, demands, suits, actions, proceedings, fines, claims, losses (including attorneys' fees) or the cleanup, response, removal or remediation of any environmental condition arising from or alleged to arise from a violation of any such environmental law, rule, or regulation, unless and except where such violation shall have been caused solely by the fault of the Railroad.

19.4 Without limiting any other provision of this Agreement, Railroad shall have the right to enter and inspect the Facilities in order to determine whether Licensee is complying with

such laws, rules, and regulations, but no such inspection or absence of inspection by Railroad shall be construed to relieve Licensee of its obligations to comply with all such laws, rules and regulations.

- 19.5 In the event any cleanup, response, removal or remediation of any environmental condition is required by a governmental entity (hereinafter collectively referred to as “Response Action”), Licensee shall not be entitled to any damages, actual or consequential, by reason of the Response Action’s interference with Licensee’s use of the Facilities. Licensee shall not be entitled to abatement in the rent for any interference with Licensee’s use of the Facilities due to a Response Action. Licensee shall permit Railroad and its contractor’s full, unrestricted and unconditional access to the Facilities for the purpose of completing or engaging in a Response Action for which Licensee is responsible should Licensee fail to diligently pursue and complete such Response Action to the satisfaction of Railroad. Railroad’s completion of any Licensee’s obligations hereunder shall not be deemed a waiver of Licensee’s obligations under this Agreement. Railroad shall have the right, but not the obligation, to conduct reasonable inspections of Licensee’s Response Action and Licensee shall provide Railroad all information requested by Railroad regarding Licensee’s Response Action or any environmental condition for which Licensee is responsible.
20. This Agreement contains the entire agreement of Railroad and Licensee and supersedes any prior understanding or agreement between Railroad and Licensee respecting the subject matter hereof, and no representations, warranties, inducements, promises or agreements, oral or otherwise, between the parties not embodied in this Agreement shall be of any force or effect.
21. Licensee shall, at its sole cost and expense, procure and maintain during the life of this Agreement the insurance coverage as outlined in **EXHIBIT “B”**.
22. (a) Safety of personnel, property, rail operations and the public is of paramount importance in the prosecution of any work on Railroad’s property performed by Licensee or its contractor, and takes precedence over any work on Licensee’s Facilities to be performed by Licensee or its contractors. Licensee shall be responsible for initiating, maintaining and supervising all safety operations and programs in connection with any work on Licensee’s Facilities.
- (b) Licensee shall keep the job site on Railroad property free from safety and health hazards and ensure that their employees are competent and adequately trained in safety and health aspects of the work.
- (c) Licensee represents and warrants that all parts of the Licensee’s Facilities within and outside of the limits of Railroad property will not interfere whatsoever with the constant, continuous, and uninterrupted use of the tracks, property, and facilities of Railroad, and nothing shall be done or suffered to be done by Licensee at any time that would in any manner impair the safety thereof.
23. Any Notice required or permitted to be served under the terms of this Agreement shall be sent by certified mail, postage fully prepaid, and return receipt requested, to the parties at the following addresses:
- To Railroad: Stillwater Central Railroad, L.L.C.
315 West 3rd Street
Pittsburg, KS 66762
Attn: Manager – Real Estate

To Licensee: Chickasha Municipal Authority
c/o City of Chickasha
117 N 4th Street
Chickasha, OK 73018
Attn: Jim Crosby

or at such other address as the respective parties may from time to time give notice of.

23. This Agreement may be executed in counterparts, each of which shall be deemed an original, but all of which together shall constitute one instrument. This Agreement may be validly executed and delivered by telephonic facsimile transmission, e-mail transmission, or other electronic means including, without limitation, through the use of DocuSign or similar service, and the signatures on such electronic copies, whether generated electronically or manually, shall be deemed to be original signatures.

24. This Agreement shall cancel and supersede prior agreements, if any, by and between Railroad and Licensee, or the predecessors of either, covering any of the FACILITIES herein.

The terms of this Agreement shall be binding and effective upon all the parties hereto, and unless and until terminated, as hereinbefore provided, this Agreement shall inure to the benefit of and be binding upon the parties hereto, their successors and assigns, subject, however, to the provisions of Article "15" of this Agreement.

IN WITNESS WHEREOF, the said parties hereto have caused this Agreement to be duly executed and delivered as of the day and year first above written.

STILLWATER CENTRAL RAILROAD, L.L.C.
(as Railroad)

CHICKASHA MUNICIPAL AUTHORITY
(as Licensee)

By: _____

By: _____

Name: Justin Mahr

Name: _____

Title: Director Public Projects & Utility Infrastructure

Title: _____

Case Number: 00076219

Exhibit A Summary

Exhibit A on the following page

Summary Table

1.	License #	SLWC530792
2.	Railroad	Stillwater Central Railroad, L.L.C.
3.	Licensee	Chickasha Municipal Authority
4.	Description of Work	Proposed installation of a new underground transverse pipeline crossing consisting of one (1) 26-inch ductile iron water pipeline encased within a 36-inch steel pipe at Mile Post 580.17 added to existing facilities comprised of one (1) 18-inch longitudinal water pipeline within railroad right-of-way for 2,160 linear feet and one (1) 18-inch water pipeline encased within a 28-inch steel pipe crossing at Mile Post 580.15, at or near Chickasha, Grady County, OK.
5.	City, County, State	Chickasha, Grady, OK
6.	Mile Post	580.17
7.	Latitude/Longitudinal Coordinates	35.06344200000, -97.92911400000

Pipe Data

	Carrier	Casing
Contents to be handled:		Ductil Iron Carrier Pipe
Normal operating pressure:	140 psi	N/A
Outside diameter:	25.8 inch	36 inch
Inside diameter:	25.14 inch	34.938 inch
Wall thickness:	0.33 inch	0.531 inch
Weight per foot:	95 lbs	202 lbs
Material:	Ductile Iron	Steel
Process of manufacture:	Centrifugally Cast	Welded Steel Casing Pipe
Specification:	AWWA C151	ASTM A252
Grade or class:	pressure class 200 psi	Grade 3
Test pressure:	280 psi	N/A
Type of joint:	Push-On, Internally	Welded
Type of coating:	Arc-Sprayed Zinc & 1 Mil	None
Details of cathodic protection:	Using Polyethelene	N/A
Details of seal or protection at ends of casing:	Carrier To Have Spacer	Flowable Fill Grout Seal, 12"
Method of installation:		
Character of subsurface material at the crossing location:		
Approximate ground water level:	1078	1078
Source of information on subsurface conditions (borings, test pits or other):	Borings	Borings

ACAD Ref: 24.1s (LMS Tech)
 Filename: P:\140_CivIn\1400384 FNI Chickasha Water Treatment\21DesignWorking\CIVL\05AutoCAD\25sheets\CV-BNH-PP-WATER01.dwg
 Last Saved: 10/14/2025 2:52 PM Saved By: BTRhodes

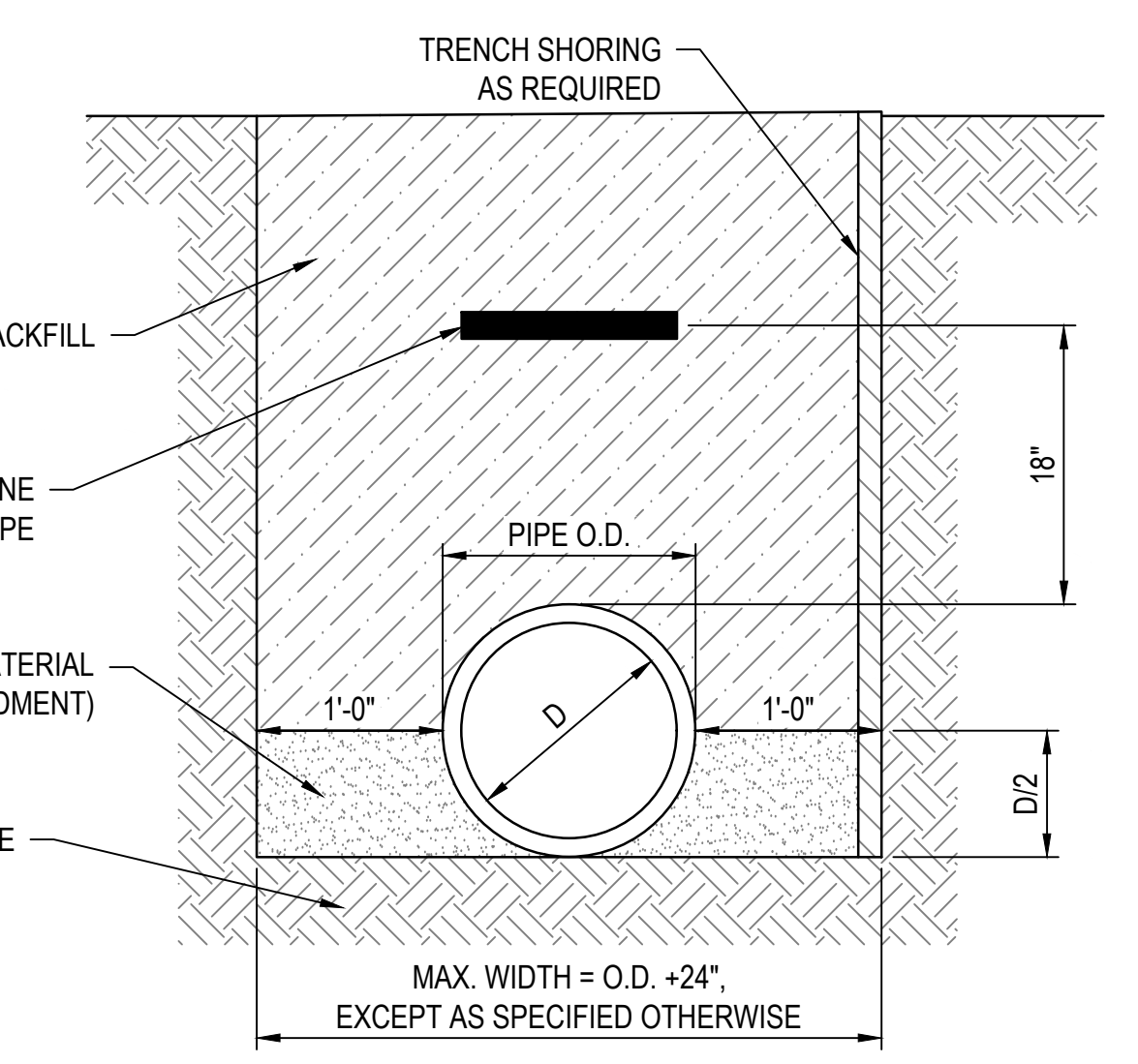
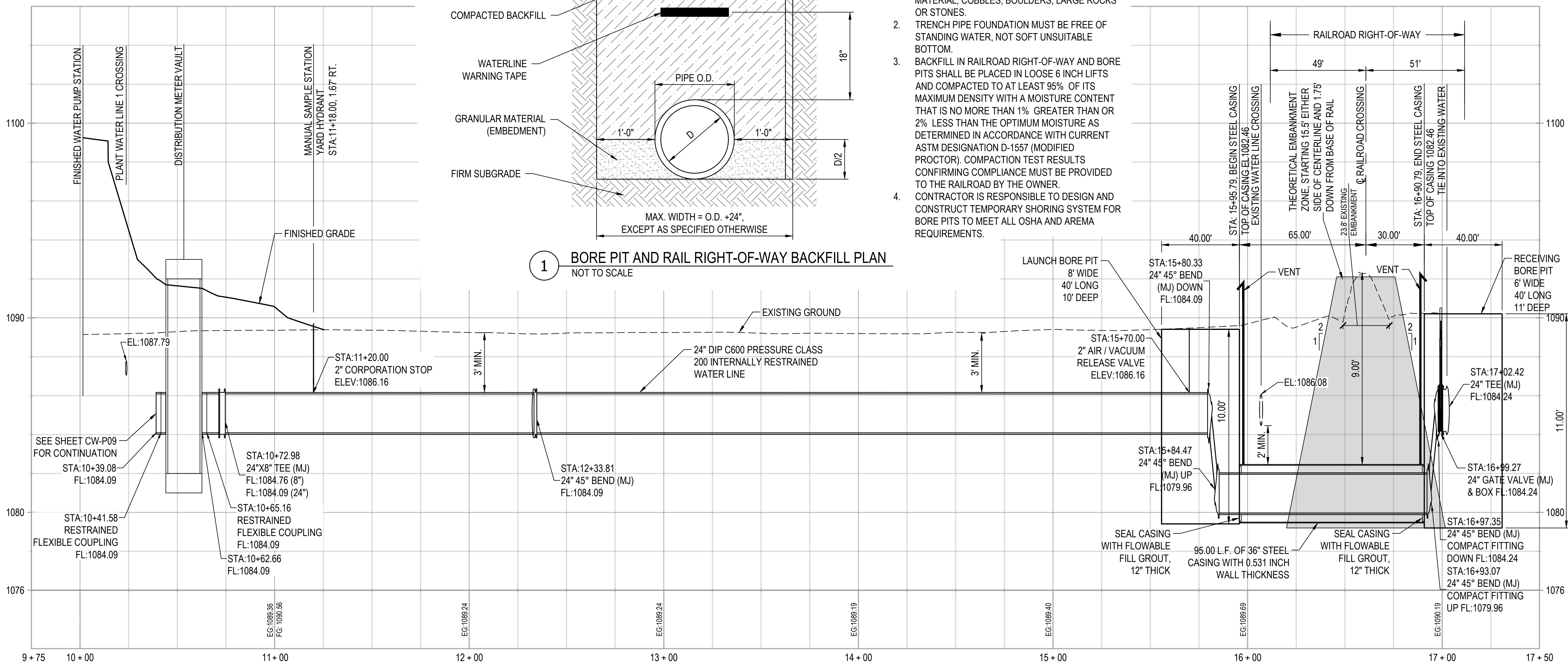
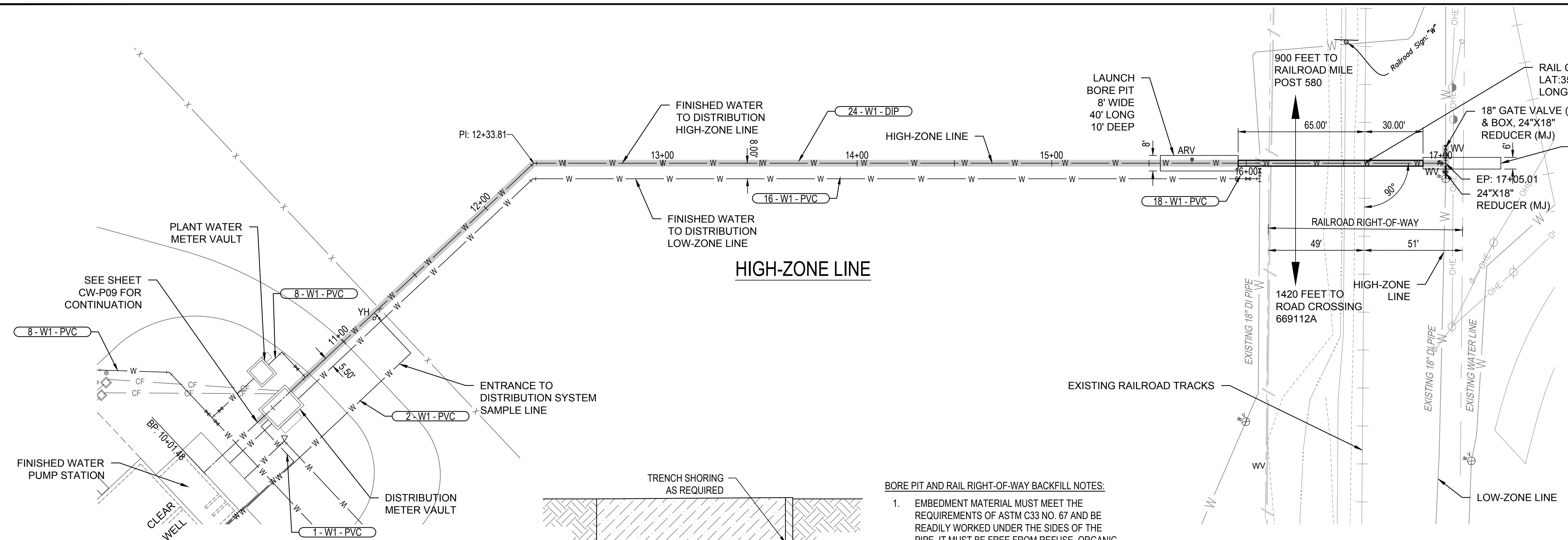

- BORE PIT AND RAIL RIGHT-OF-WAY BACKFILL NOTES:**
- EMBEDMENT MATERIAL MUST MEET THE REQUIREMENTS OF ASTM C33 NO. 67 AND BE READILY WORKED UNDER THE SIDES OF THE PIPE. IT MUST BE FREE FROM REFUSE, ORGANIC MATERIAL, COBBLES, BOULDERS, LARGE ROCKS OR STONES.
 - TRENCH PIPE FOUNDATION MUST BE FREE OF STANDING WATER, NOT SOFT UNSUITABLE BOTTOM.
 - BACKFILL IN RAILROAD RIGHT-OF-WAY AND BORE PITS SHALL BE PLACED IN LOOSE 6 INCH LIFTS AND COMPACTED TO AT LEAST 95% OF ITS MAXIMUM DENSITY WITH A MOISTURE CONTENT THAT IS NO MORE THAN 1% GREATER THAN OR 2% LESS THAN THE OPTIMUM MOISTURE AS DETERMINED IN ACCORDANCE WITH CURRENT ASTM DESIGNATION D-1557 (MODIFIED PROCTOR). COMPACTION TEST RESULTS CONFIRMING COMPLIANCE MUST BE PROVIDED TO THE RAILROAD BY THE OWNER.
 - CONTRACTOR IS RESPONSIBLE TO DESIGN AND CONSTRUCT TEMPORARY SHORING SYSTEM FOR BORE PITS TO MEET ALL OSHA AND AREMA REQUIREMENTS.

BENHAM
 a Haskell Company

14000 Quail Springs Pkwy, Ste. 500
 Oklahoma City, OK 73134
 Certificate of Authorization: 7569
 Expiration Date: 06/30/2026

BRANDON RHODES
 LICENSED PROFESSIONAL ENGINEER
 OKLAHOMA
 10-03-25

FREES & NICHOLS
 3600 NW 138th St, Suite 202
 Oklahoma City, OK 73134
 Phone: (405) 607-7060
 Web: www.frees.com
 Certificate of Authorization: CA#511
 Expiration Date: 06/30/2026

LEGEND:

- W — EXISTING WATER
- W — WATER
- PW — PROCESS WATER
- FH — FIRE HYDRANT
- FDC — FIRE DEPARTMENT CONNECTION
- YH — YARD HYDRANT
- BOLLARD
- WV — WATER VALVE
- BUV — BUTTERFLY VALVE
- PGV — PLUG VALVE
- ARV — AIR/VACUUM RELEASE VALVE
- BV — BLOW OFF
- REDUCER
- THRUST BLOCK
- RIPRAP
- CF — CHEMICAL FEED

- NOTES:**
- FOR UTILITY NOTES REFER TO SHEET G-605; WATER, SANITARY SEWER AND RESIDUAL LINE NOTES.
 - FOR SANITARY SEWER DETAILS REFER TO CITY OF CHICKASHA STANDARD DETAILS SHEET SSM1 TO SSM4.
 - FOR WATER MAIN DETAILS REFER TO CITY OF CHICKASHA STANDARD DETAILS SHEET WM1 TO WM5.
 - STEEL CASING TO BE ASTM A252, GRADE 3 WELDED JOINT STEEL.
 - PROVIDE SPACERS FOR CARRIER PIPE WITHIN CASING PIPE AT MAX. 6' APART.

PS-C25

100% SUBMITTAL

NO.	ISSUE	REVISION #1	DATE	DESIGNED	DRAWN	CHECKED	APPROVED	FILE NAME
1			10/03/2025	BTR				CV-BNH-PP-WATER01.dwg

Bar Scale is one inch on original drawing. If not one hinch on this sheet, adjust 1" scale.

CITY OF CHICKASHA, OK
WATER TREATMENT PLANT IMPROVEMENTS PROJECT
 CIVIL
PROJECT SITE FINISHED WATER PLAN AND PROFILE 02

ACAD Ref: 24.1s (LMS Tech)
 Filename: P:\140_CivIn\1400384 FNI Chickasha Water Treatment\21DesignWorking\CIVL\03DueDiligence\Distribution Lines\Rail Crossing\Ex WL Long to Rail.dwg
 Last Saved: 10/14/2025 3:08 PM. Saved By: BTRhodes



14000 Quail Springs Pkwy, Ste. 500
 Oklahoma City, OK 73134
 Certificate of Authorization: 7569
 Expiration Date: 06/30/2026

FOR INFORMATION ONLY

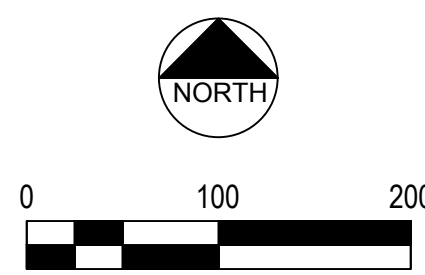

3600 NW 138th St., Suite 202
 Oklahoma City, OK 73134
 Phone - (405) 607-7060
 Web - www.freese.com
 Certificate of Authorization: CA#511
 Expiration Date: 06/30/2026

CITY OF CHICKASHA, OK
 WATER TREATMENTS PLANT
 IMPROVEMENTS PROJECT

CIVIL
 PROJECT SITE
 RR EXHIBIT 'A'

NO.	ISSUE	BY	DATE	FRN JOB NO.
0	VERIFY SCALE			CHK23639
				DATE
				OCT 2025
				DESIGNED
				BR
				DRAWN
				BR
				IF
				CH
				CH
				APPROVED
				BR
				FILE NAME
				Ex WL Long to Rail.dwg

SHEET
 RR EX-A
 SEQ.

100% SUBMITTAL

Exhibit B

INSURANCE REQUIREMENTS FOR: Pipeline License		
<p>Licensee shall, at its sole cost and expense, procure and maintain during the life of this License the insurance coverage identified below. Licensee must provide a Certificate of Insurance certifying that the insurance limits and coverages, with the appropriate endorsements, all as outlined below are in effect.</p>		
<u>COVERAGE TYPE</u>	>	<u>MINIMUM COVERAGE</u>
<p>Commercial General Liability (CGL)</p> <p>Must include coverage for blanket contractual liability for the obligations assumed under contract including but not limited to:</p> <ul style="list-style-type: none"> · Bodily injury and property damage · Fire legal liability · Pollution liability (sudden and accidental) · Emergency evacuation · The definition of insured contract shall be amended to remove any exclusion or other limitation for any work being done within 50 feet of rail property, if applicable. · Any exclusions related to the explosion, collapse and underground hazards shall be removed. · No other endorsements limiting coverage may be included on the policy with regards to the work being performed under this agreement. 	>	<p>\$10,000,000 Per Occurrence</p>
<p>All Risk Property</p> <p>All risks property insurance covering all of Licensee's property including property in the care, custody or control of Licensee. Coverage shall include the following:</p> <ul style="list-style-type: none"> · Issued on a replacement cost basis. · Include a standard loss payable endorsement naming Railroad as the loss payee as its interests may appear. 	>	<p>Replacement Value</p>
<p>Automobile Liability</p> <p>Coverage must extend to all owned, hired, and non-owned vehicles and must include coverage for blanket contractual liability for the obligations assumed under contract.</p> <p>If applicable, Motor Carrier Act Endorsement – Hazardous materials clean up (MCS-90) is required.</p>	>	<p>\$2,000,000 Combined Single Limit Each Occurrence</p>
<p>Workers' Compensation</p> <p>Employers Liability</p>	>	<p>Statutory Limits where Services are to be performed</p> <p>\$1,000,000 Each Occurrence</p> <p>\$1,000,000 Disease Per Employee</p>
<p>Must include coverage for Longshoremen's and Harbor Workers' Compensation, if applicable, and coverage for Federal Employers' Liability Act, if applicable.</p>		
<p>Pollution Liability</p> <p>Pollution Liability coverage must be included when the scope of the work as defined in the Agreement includes installation, temporary storage, or disposal of any "hazardous" material that injurious in or upon land, the atmosphere, or any watercourses; or may cause bodily injury at any time.</p> <p>The policy shall provide for protection against claims for third-party bodily injury, property damage, environmental damage and clean-up cost caused by pollution conditions resulting from actions taken under this contract.</p> <p>If the scope of work as defined in this Agreement includes the disposal of any hazardous or non-hazardous materials from the job site, Licensee must furnish to Railroad evidence of pollution legal liability insurance maintained by the disposal site operator for losses arising from the insured facility accepting the materials, with coverage in minimum amounts of \$1,000,000 per loss, and an annual aggregate of \$2,000,000.</p>	>	<p>\$10,000,000 Per Occurrence</p>
<p>Railroad Protective Liability</p>	>	<p>\$2,000,000 Per Occurrence</p> <p>\$6,000,000 Aggregate</p>

**An Umbrella liability policy, which follows form, may be used to obtain the aforementioned limits.

Insurance Requirements continued on following page

Certificate Holder and Endorsement Requirements

1. Railroad shall be listed as Certificate Holder as follows: Watco Companies, L.L.C., and its affiliates, subsidiaries and assigns 315 W. 3rd Street Pittsburg, KS 66762.
2. All aforementioned policies shall contain a blanket waiver of subrogation in favor of Certificate Holder, and an additional insured endorsement naming Certificate Holder as Additional Insured (with the exception of Workers' Compensation and Employer's Liability). All aforementioned policies shall be primary and non-contributory with respect to any insurance carried by Railroad.
3. If any policies are purchased on a "claims made" basis, Licensee hereby agrees to maintain coverage in force for a minimum of three years and shall provide evidence of such coverage to Railroad, on an annual basis, during this additional three-year period.

Other Requirements

1. All policies required shall be written by a reputable insurance company reasonably acceptable to Railroad or with a Best's Guide Rating of A- and Class VII or better and authorized to do business in the state(s) in which Licensee is conducting business.
2. Licensee shall notify Railroad in writing at least thirty (30) days prior to any cancellation, non-renewal, and substitution or material alteration to any of the aforementioned policies.
3. Failure to provide evidence as required shall entitle, but not require, Railroad to terminate immediately.
4. Acceptance of a certificate that does not comply with this document shall not operate as a waiver of Licensee's obligations hereunder.
5. Licensee is not allowed to have a self-insure greater than \$250,000 without prior written consent of Railroad. If granted by Railroad, any deductible, self-insured retention or other similar financial responsibility for claims shall be covered directly by Licensee in lieu of insurance. Any and all Licensee liabilities that would otherwise, in accordance with the provisions of this document, be covered by Licensee's insurance will be covered as if Licensee elected not to include a deductible, self-insured retention or other financial responsibility for claims.
6. If any portion of the operation is to be subcontracted by Licensee, Licensee shall require that the subcontractor shall provide and maintain insurance coverage as set forth herein, naming Railroad as an additional insured, and shall require that the subcontractor shall release, defend and indemnify Railroad to the same extent and under the same terms and conditions as Licensee is required to release, defend and indemnify Railroad herein.
7. Failure to provide evidence as required by this section shall entitle, but not require, Railroad to terminate this agreement immediately. Acceptance of a certificate that does not comply with this section shall not operate as a waiver of Licensee's obligations hereunder.
8. The fact that insurance (including, without limitation, self-insurance) is obtained by Licensee shall not be deemed to release or diminish the liability of Licensee including, without limitation, liability under the indemnity provisions of this License. Damages recoverable by Railroad shall not be limited by the amount of the required insurance coverage.

CHICKASHA

Meeting Type: CMA Agenda 5-4-2026

Meeting Date: 5/4/2026

Department: Administration

Agenda Item No. 4.e.

AGENDA ITEM: Discussion, consideration, and possible action to approve a Contract Amendment Between Fort Cobb Reservoir Master Conservancy District and the Chickasha Municipal Authority, Chickasha, Oklahoma to Extend the May 14, 1992, Contract for an Additional 5-Year Term and authorize the Chairman to execute the same.

I. BACKGROUND/DESCRIPTION:

II. RECOMMENDED ACTION:

Approve a Contract Amendment Between Fort Cobb Reservoir Master Conservancy District and the Chickasha Municipal Authority, Chickasha, Oklahoma to Extend the May 14, 1992, Contract for an Additional 5-Year Term and authorize the Chairman to execute the same.

III. FISCAL INFORMATION -

IV. FUND INFORMATION:

Dept. Director: Jim Crosby, City Manager	Fund	Account	Amount
	(To)		
Meeting Date: May 4, 2026	FUND	ACCOUNT	AMOUNT
	(From)		

V. ATTACHMENTS:

1. Fort Cobb and Chickasha May 14 1992 Contract Amendment 2026.4.17 (1)

**CONTRACT AMENDMENT
BETWEEN
FORT COBB RESERVOIR MASTER CONSERVANCY DISTRICT
AND THE
CHICKASHA MUNICIPAL AUTHORITY
CHICKASHA, OKLAHOMA
TO EXTEND THE MAY 14, 1992 CONTRACT FOR AN ADDITIONAL 5-YEAR TERM**

This CONTRACT AMENDMENT, made this _____ day of the month of _____, 2026, is between the FORT COBB RESERVOIR MASTER CONSERVANCY DISTRICT (District) and the CHICKASHA MUNICIPAL AUTHORITY (Authority), a public trust, each duly created and existing under the laws of the State of Oklahoma.

WITNESSETH, THAT

WHEREAS, the District has contracted with the United States for repayment of the costs of constructing the Fort Cobb Division of the Washita River Basin Reclamation Project (Project), Oklahoma (Contract No. 14-06-500-295), dated July 23, 1957, as amended and supplemented; and

WHEREAS, the Authority has been receiving water from the Project pursuant to a contract with the District since the 8th day of September 1966; and

WHEREAS, the District and Authority executed a new Contract on the 14th day of May 1992, (Existing Contract), Article 15(a) of which states that this Contract shall continue thereafter for a period of twenty (20) years and may be renewed by the Authority thereafter for one period of ten (10) years and further renewed thereafter upon mutual agreement of the parties; and

WHEREAS, the District and Authority renewed and extended the Existing Contract on the 18th day of May 2010 for one period of ten (10) additional years as allowed under Article 15(a), resulting in a Contract expiration date of June 30, 2021; and

WHEREAS, Article 15(a) further states that following the 10-year extension, the Existing Contract may be renewed thereafter upon mutual agreement of the parties; and

WHEREAS, on June 11th, 2021, the District and the Authority pursuant to Article 15(a), extended the Existing Contract for an additional 5-year period; and

WHEREAS, the District signed a Memorandum of Agreement on the 15th day of March 2013 to participate in the Upper Washita Basin Study (UWBS) in collaboration with the Oklahoma Water Resources Board and Bureau of Reclamation (Reclamation); and

WHEREAS, under the UWBS, Reclamation is updating its firm yield estimate of Fort Cobb Reservoir (Reservoir), taking into consideration the potential impacts of current and future development of ground- and surface-water resources within the drainage basin contributing inflow into the Reservoir. Reclamation also is developing designs and cost estimates for

alternatives to convey water from the Reservoir to the District's member entities and to the Authority; and

WHEREAS, the UWBS that was scheduled to be completed in 2023 is now anticipated to be completed in 2028; and

WHEREAS, the parties agree to extend the Existing Contract, as amended and supplemented for an additional 5-year period.

NOW, THEREFORE, in consideration of the mutual and dependent covenants herein contained, it is agreed between the parties hereto as follows:

ARTICLE 4 **RATES** of May 14, 1992, Contract was amended on June 11, 2021. Article 4 **RATES** shall now be further amended as follows:

Replace 2021 rate of twenty-three (23) cents with twenty-nine (29) cents.

Replace 2021 rate of six (6) cents with eight (8) cents.

Replace 2021 rate of sixteen (16) cents with twenty-one (21) cents.

Except as specifically altered herein, the Existing Contract, as amended, remains in full force and effect.

**FORT COBB RESERVOIR
MASTER CONSERVANCY DISTRICT**

**CHICKASHA MUNICIPAL
AUTHORITY**

Concurrence:

BUREAU OF RECLAMATION

Brent C Esplin